



TM_AF_R410A_ONOFF_SA_NA_2008

FOREST R410A ONOFF CONTROL

TECHNICAL MANUAL

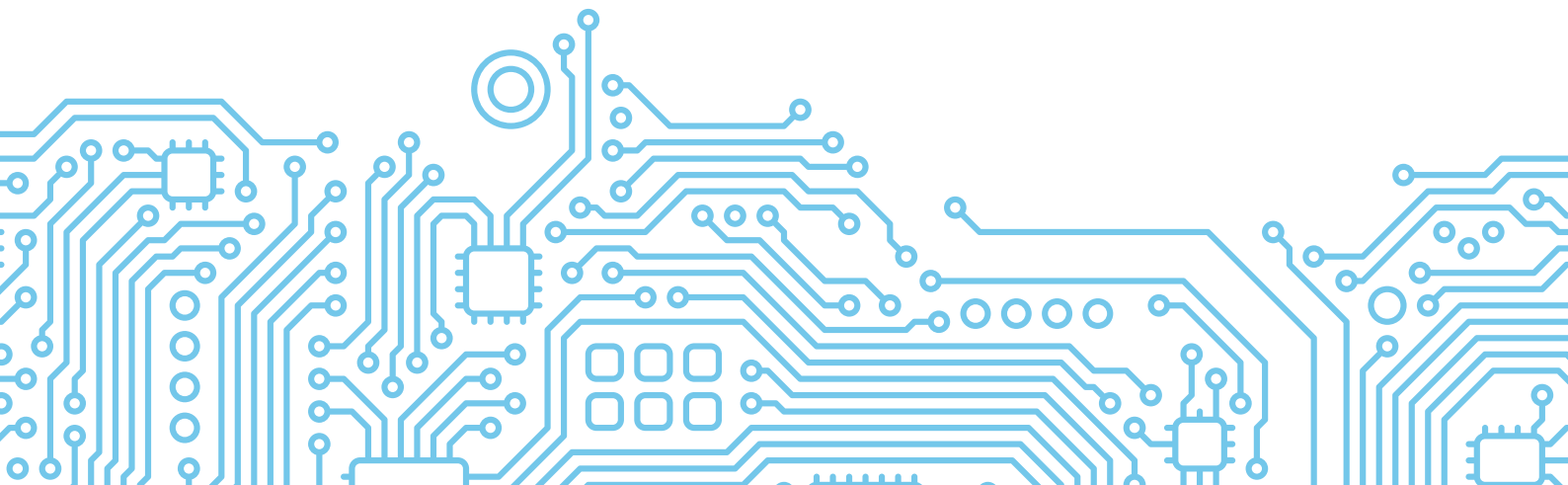
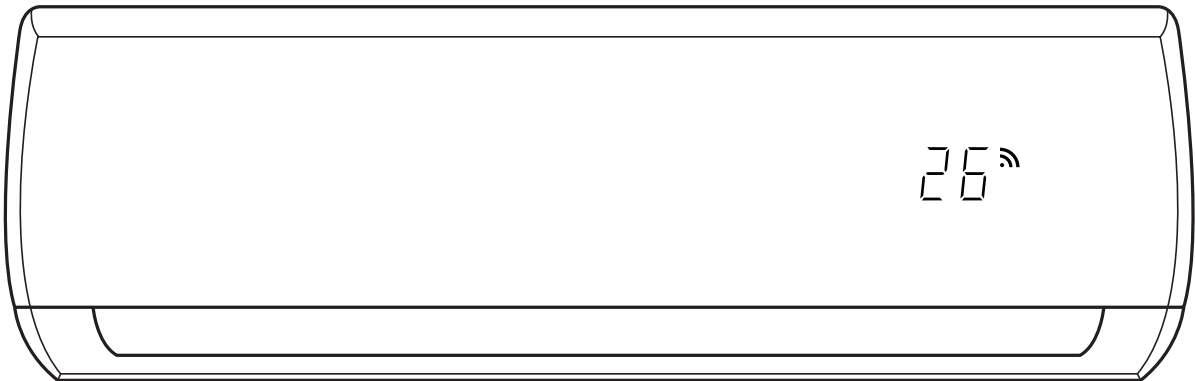

Table of Contents

Page

1. Specifications	3
1. Model Reference	
2. General Specifications	
3. Dimensional Drawings	
4. Electrical Wiring Diagrams	
5. Refrigerant Cycle Diagrams	
6. Capacity Tables	
7. Capacity Correction Factor for Height Difference	
8. Noise Criterion Curves	
9. Electrical Characteristics	
2. Product Features	28
1. Operation Modes and Functions	
2. Remote Controller Functions	
3. Installation	34
1. Installation Overview	
2. Location Selection	
3. Indoor Unit Installation	
4. Outdoor Unit Installation	
5. Refrigerant Pipe Installation	
6. Vacuum Drying and Leakage Checking	
7. Additional Refrigerant Charge	
8. Electrical and Gas Leak Checks	
9. Test Operation	

Specifications

Contents

1.	Model Reference.....	4
2.	General Specifications.....	5
3.	Dimensional Drawings.....	7
4.	Electrical Wiring Diagrams.....	11
5.	Refrigerant Cycle Diagrams.....	15
6.	Capacity Tables.....	16
7.	Capacity Correction Factor for Height Difference.....	22
8.	Noise Criterion Curves.....	23
9.	Electrical Characteristics.....	27

1. Model Reference

Refer to the following table to determine the specific indoor and outdoor unit model number of your purchased equipment.

Outdoor Unit Model	Indoor Unit Model	Capacity (Btu/h)	Power Supply
MOAA31-12CN1-NB8	MSAFB-12CRN1-NB8	12k	1 Φ , 220~230V~, 60Hz
MOBA32-18CN1-NB8	MSAFC-18CRN1-NB8	18k	
MOCA30-24CN1-NB8W	MSAFD-24CRN1-NB8W	24k	

2. General Specifications

Model		MSAFB-12CRN1-NB8	MSAFC-18CRN1-NB8	MSAFD-24CRN1-NB8W	
Power supply	V- Ph-Hz	220~230-1-60	220~230-1-60	220~230-1-60	
Max. input consumption	W	1850	2300	3500	
Max. current	A	9.0	11.9	17	
Starting current	A	28.5	41.9	58.0	
Compressor	Model	ASM120N2UDZB	PA170M2A-3FT6	PA225M2AS-3MT6	
	Type	ROTARY	ROTARY	ROTARY	
	Brand	GMCC	GMCC	GMCC	
	Capacity	W	3595/3650	5055/5155	6650/6715
	Input	W	1140/1140	1645/1660	2180//2240
	Rated current(RLA)	A	5.55/5.10	8.05/7.35	10.55/10.05
	Locked rotor Amp(LRA)	A	28.5	41.9	58
	Thermal protector		HPA -622	UP3-64	/
	Thermal protector position		INTERNAL	INTERNAL	INTERNAL
	Capacitor	uF	40.0	40.0	55.0
	Capacitor class		P2	P2	P2
	Refrigerant oil/oil charge	ml	VG74/300	VG74/420	ESTER OIL VG74/620
Indoor fan motor	Model	YKFG-20-4-10L	YKFG-28-4-6-5	YKFG-45-4-13	
	Input	W	47.4	58.5	89.0
	Insulation class		E	E	B
	IP rating		IPX0	IPX0	IPX0
	Capacitor	uF	1.5	1.5	3
	Capacitor class		P2	P2	P2
	Speed(Hi/Mi/Lo)	r/min	1150/950/800	1180/1000/800	1200/1000/900
Indoor coil	Number of rows		2.0	2.0	2.0
	Tube pitch(a)x row pitch(b)	mm	19.5x11.6	21x13.37	21x13.37
	Fin spacing	mm	1.2	1.2	1.3
	Fin type (code)		Hydrophilic aluminum	Hydrophilic aluminum	Hydrophilic aluminum
	Tube outside dia.and type	mm	Φ5,Inner groove tube	Φ7,Inner groove tube	Φ7,Inner groove tube
	Coil length x height x width	mm	595x78x23.2+595x117x23.2+595x78x23.2	750x189x26.74+750x105x26.74	780x210x26.74+780x105x26.74
	Number of circuits		4	3	4
Indoor air flow (Hi/Mi/Lo)	m3/h	593/482/388	781/669/508	1050/850/700	
Indoor sound pressure level (Hi/Mi/Lo)	dB(A)	39/34/29	41.5/37/33.5	46.5/42.0/37.0	
Indoor unit	Dimension(W*D*H)	mm	805x194x285	957x213x302	1040x220x327
	Packing (W*D*H)	mm	870x270x365	1035x295x385	1120x405x310
	Net/Gross weight	Kg	8.1/10.2	10.3/13.4	13/16

Outdoor fan motor	Model		YKT-21-6-10L	YKT-48-6-206-6	YKT-63-6-200L
	Input	W	55.5	103.8	136.0
	Insulation class		B	B	B
	IP rating		IPX4	IPX4	IPX4
	Capacitor	uF	1.5	3	3
	Capacitor class		P2	P2	P2
	Speed	r/min	870	880	810/720
Outdoor coil	Number of rows		1.0	1.0	1.0
	Tube pitch(a)x row pitch(b)	mm	14.5x12.56	19.5x11.6	19.5x11.6
	Fin spacing	mm	1.2	1.2	1.2
	Fin type (code)		Unhydrophilic aluminium	Unhydrophilic aluminium	Unhydrophilic aluminium
	Tube outside dia.and type	mm	Φ5,Inner groove tube	Φ5,Inner groove tube	Φ5,Inner groove tube
	Coil length x height x width	mm	675x406x12.56	760x507x11.6	778x663x11.6
	Number of circuits		2	2	3
Outdoor air flow		m ³ /h	1295	2091	2884
Outdoor sound pressure level		dB(A)	53	56.5	60.0
Outdoor unit	Dimension(W*D*H)	mm	681x285x434	770x300x555	845x363x702
	Packing (W*D*H)	mm	795x345x505	900x348x625	965x395x775
	Net/Gross weight	Kg	23.7/25.6	33.4/35.8	42.3/45.3
Refrigerant	Type		R410A	R410A	R410A
	Charged quantity	Kg	0.46	0.56	0.91
Design pressure		MPa	4.2/1.5	4.2/1.5	4.2/1.5
Refrigerant piping	Liquid side/ Gas side	mm(inch)	Φ6.35/Φ9.52(1/4"/3/8")	Φ6.35/Φ12.7(1/4"/1/2")	Φ9.52/Φ15.9(3/8"/5/8")
	Max. refrigerant pipe length	m	20	25	25
	Max. difference in level	m	8	10	10
Connection wiring			1.5x3Core	2.5x3Core	1.0x4Core
Plug type			16#x3/SP008	1.5x3/no-plug	1.5x3/no-plug
Thermostat type			Remote Control	Remote Control	Remote Control
Operation temperature			17-30	17-30	17-30
Ambient temperature	Indoor(cooling/ heating)	°C	17-32/-	17-32/-	17-32/-
	Outdoor(cooling/heating)	°C	18-43/-	18-43/-	18-43/-
Qty'per 20' /40' /40'HQ			124/267/300	86/180/208	64/136/146

Notes:

1) Capacities are based on the following conditions:

Cooling(T1): - Indoor Temperature 27°C(80.6°F) DB /19 °C(66.2°F) WB

-Outdoor Temperature 35 °C(95°F) DB /24 °C(75.2°F) WB

-Interconnecting Piping Length 5m

- Level Difference of Zero.

2) Capacities are Net Capacities.

3) Due to our policy of innovation some specifications may be changed without notification.

3. Dimensional Drawings

3.1 Indoor Unit

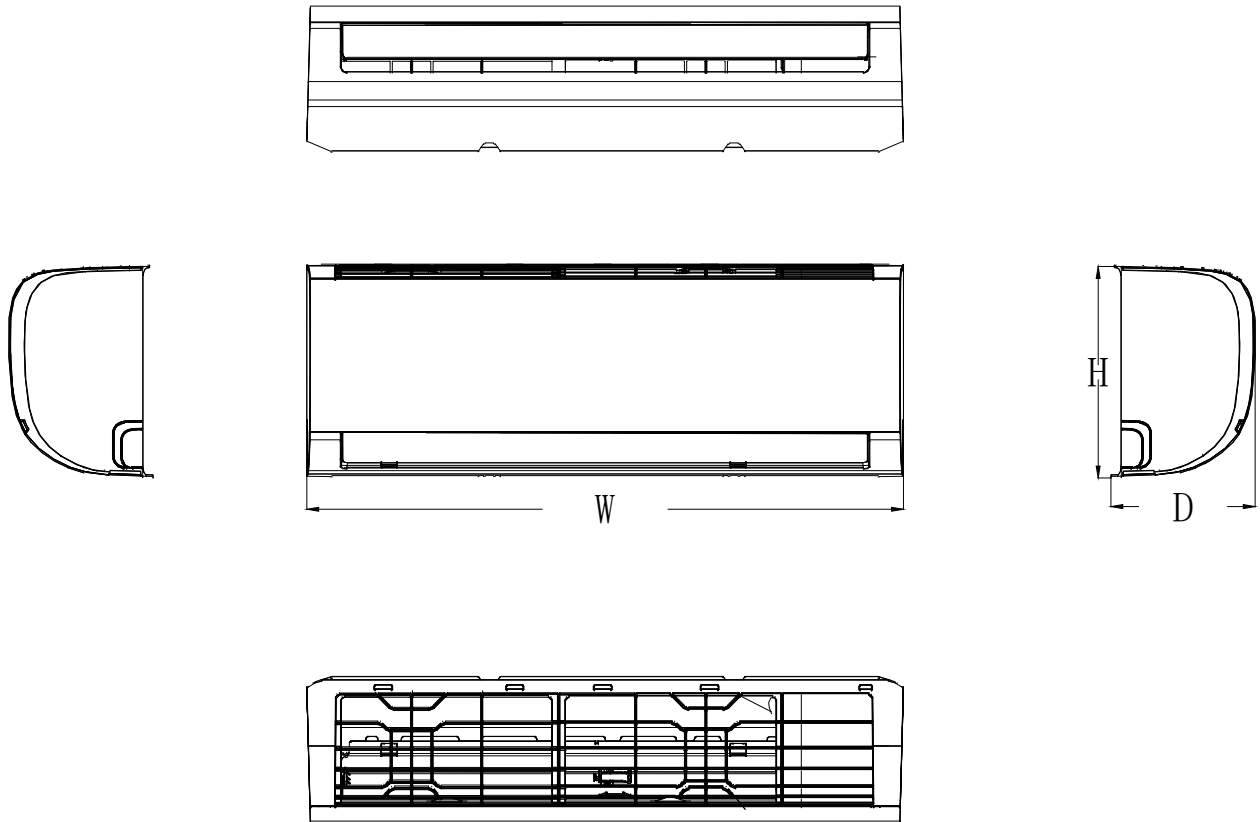

Capacity	W(mm)	D(mm)	H(mm)
12k	805	194	285
18k	957	213	302
24k	1040	220	327

3.2 Outdoor Unit

12k

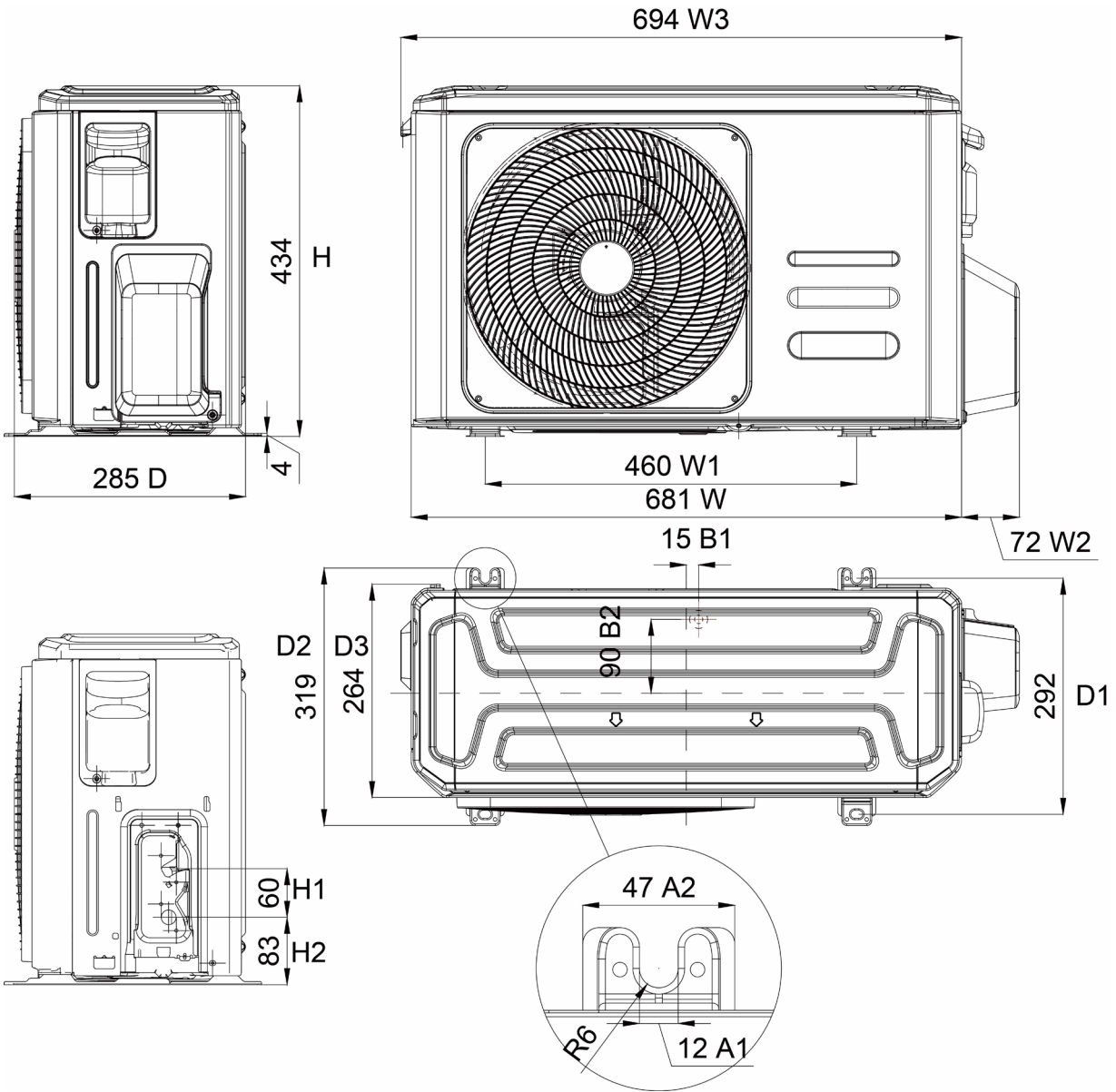

18k

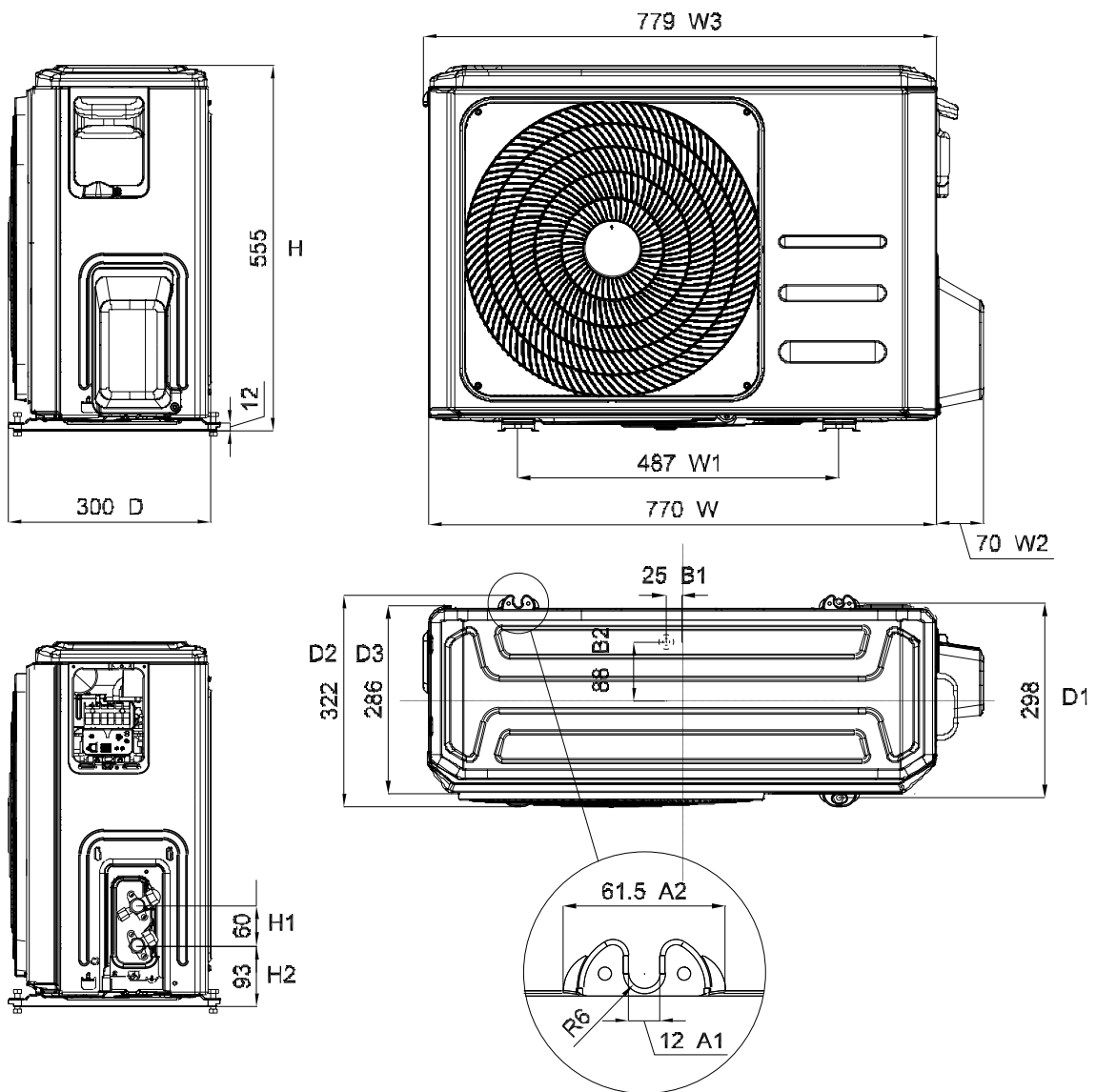

24k

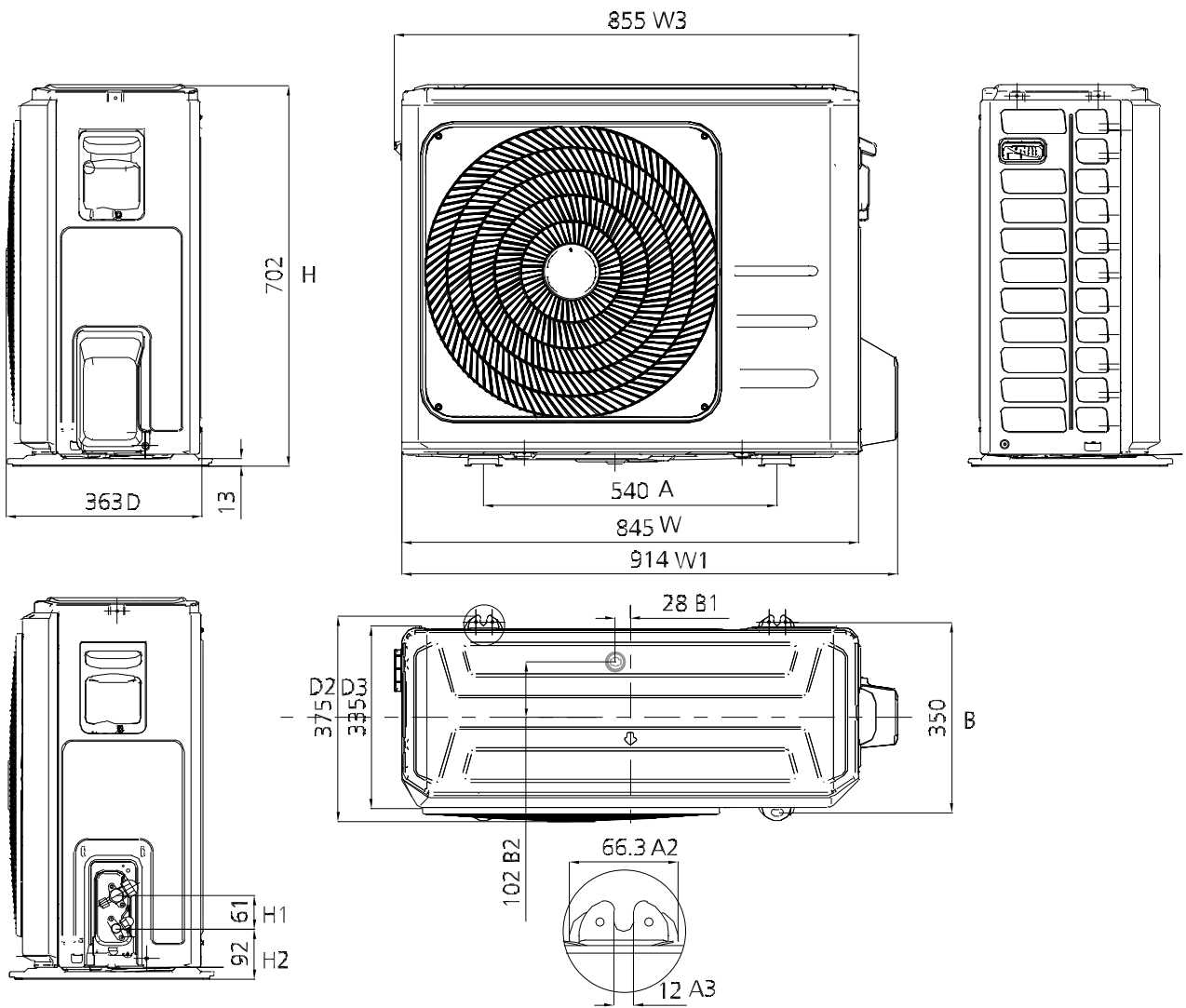

4. Electrical Wiring Diagrams

4.1 Indoor unit

Abbreviation	Paraphrase
Y/G	Yellow-Green Conductor
ION	Positive and Negative Ion Generator
CAP	Capacitor
PLASMA	Electronic Dust Collector
L	LIVE
N	NEUTRAL
T1	Indoor Room Temperature
T2	Coil Temperature of Indoor Heat Exchanger

12k/18k

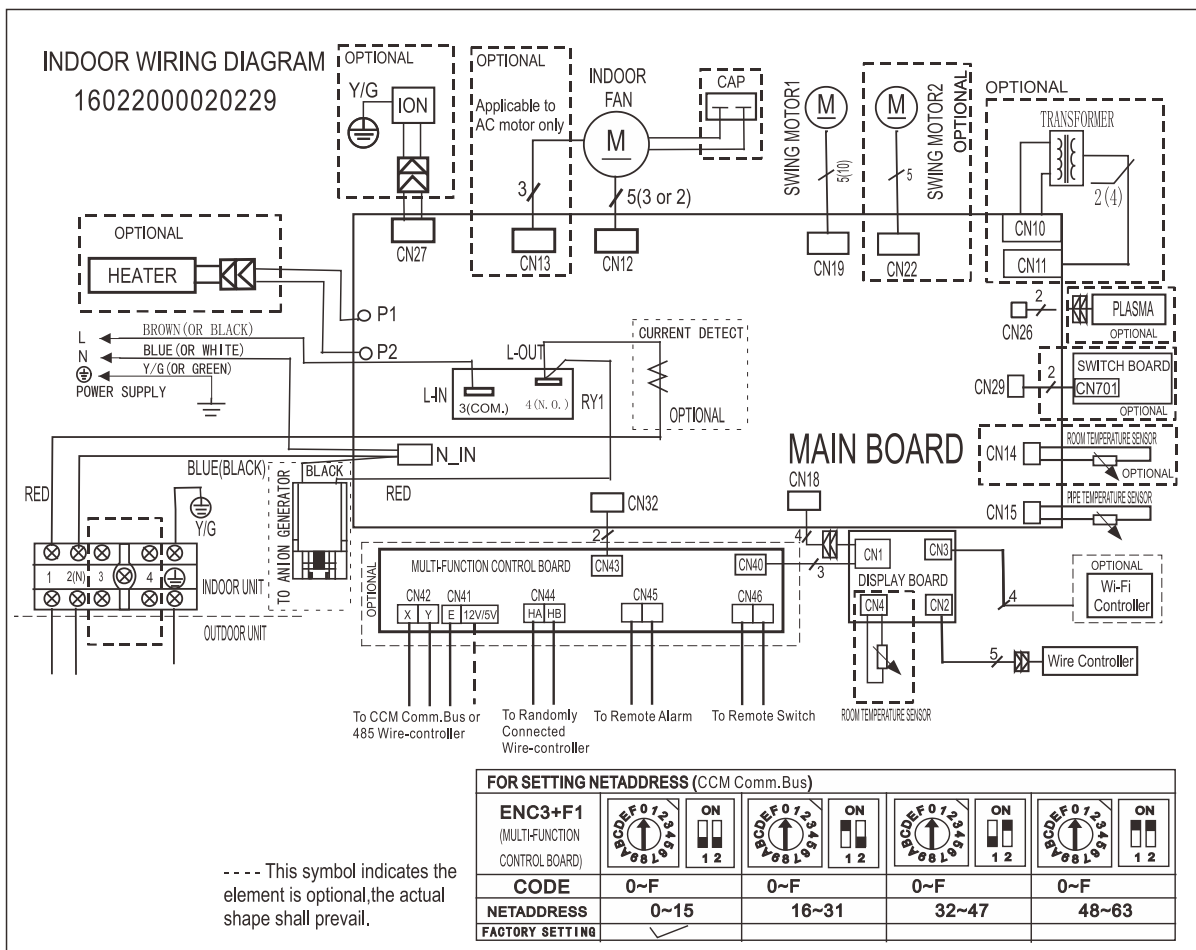

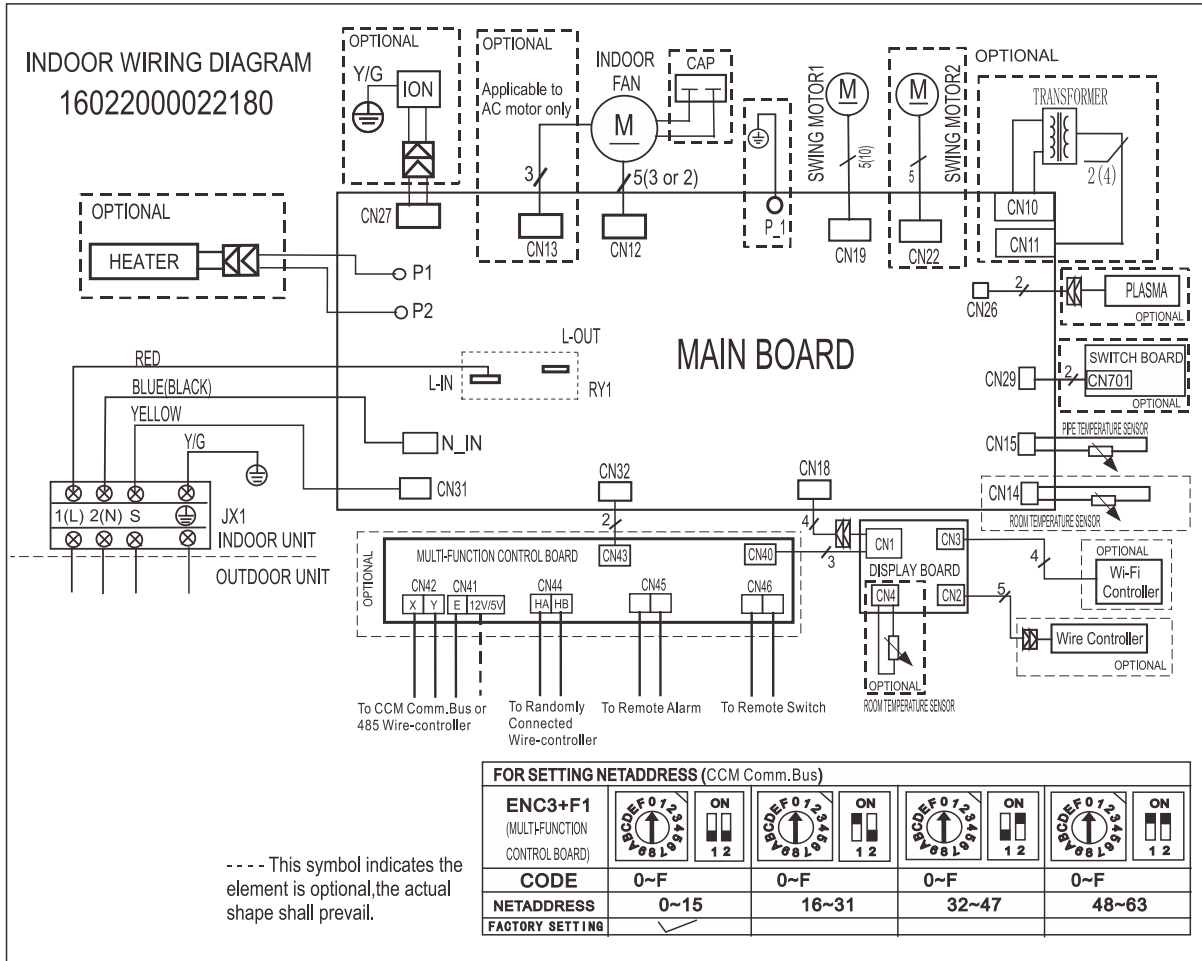

4.2 Outdoor Unit

Abbreviation	Paraphrase
4-WAY	Gas Valve Assembly/4-WAY VALVE
AC-FAN	Alternating Current FAN
DC-FAN	Direct Current FAN
COMP	Compressor

12k

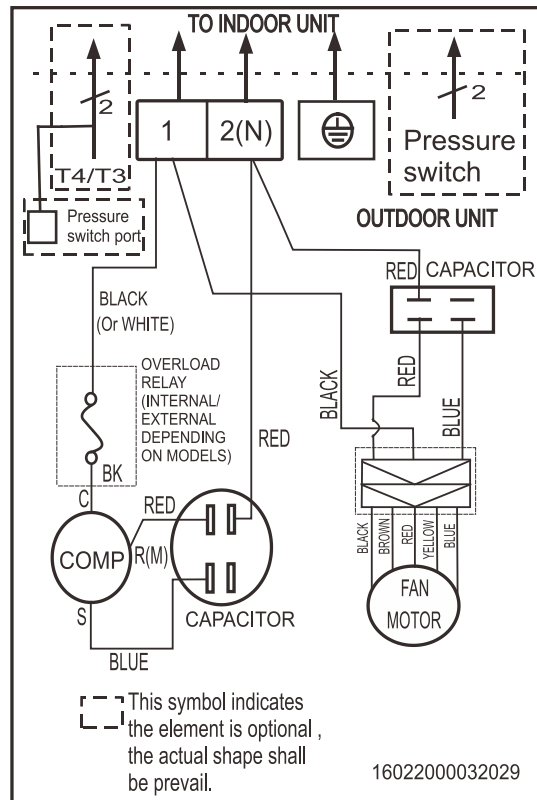

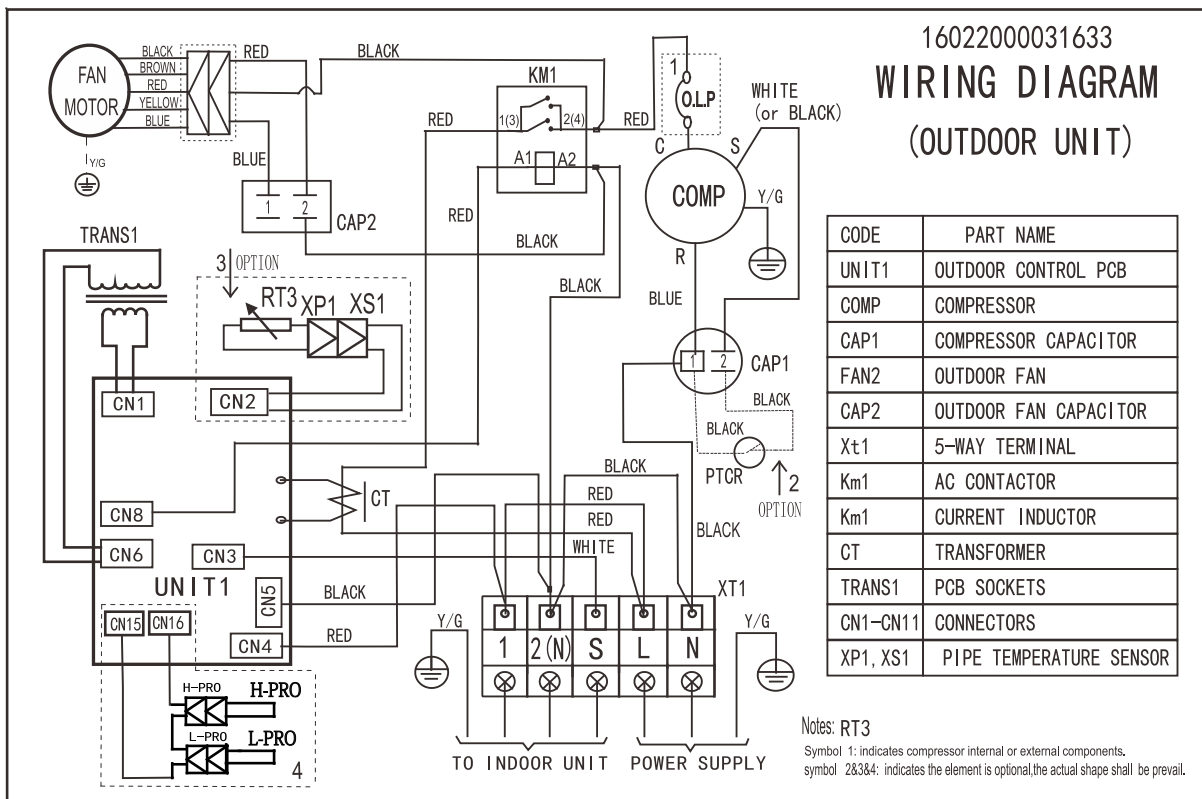
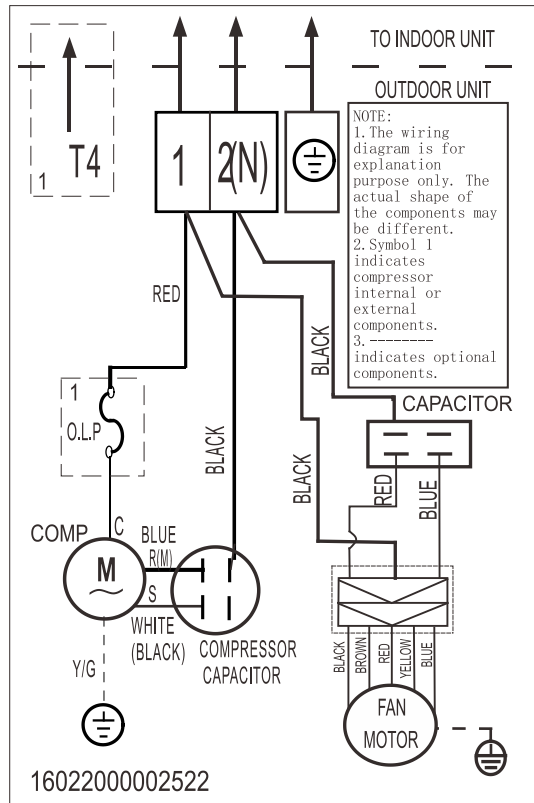

5. Refrigerant Cycle Diagrams

5.1 Cooling only

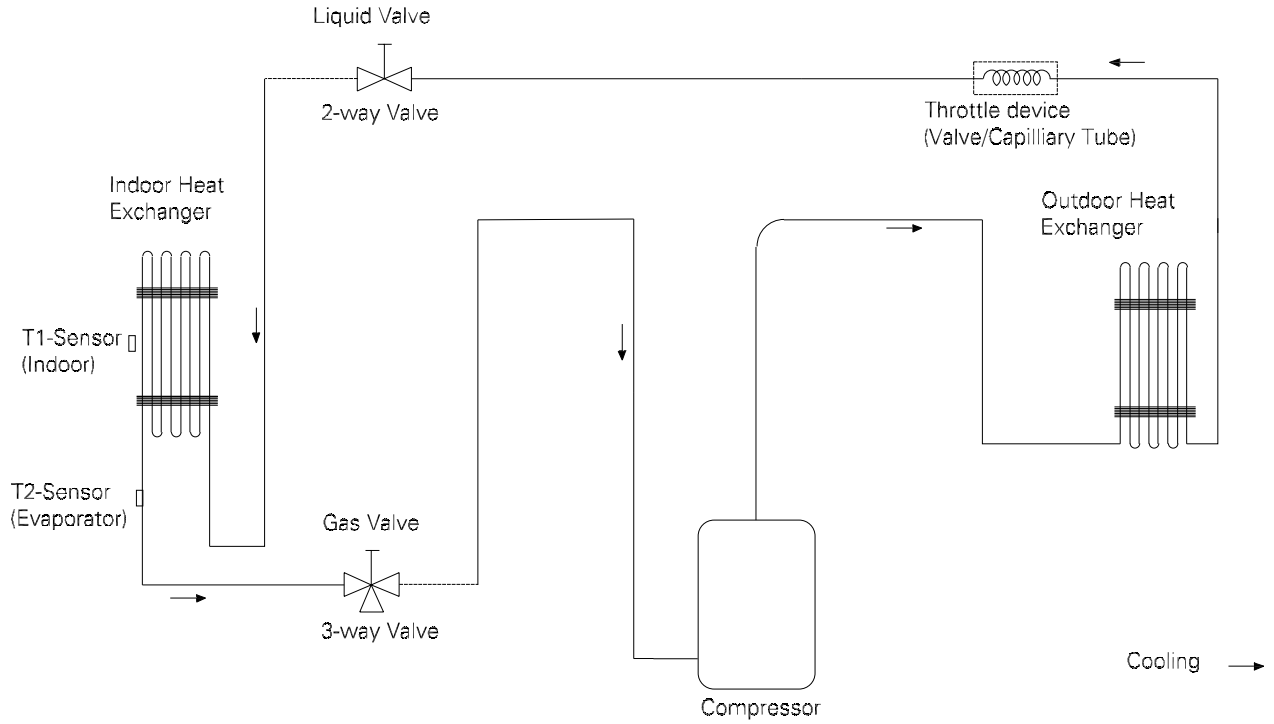

Capacity(Btu/h).	Pipe Size (Diameter:ø) mm(inch)		Piping length (m/ft)		Elevation (m/ft)		Additional Refrigerant
	Gas	Liquid	Rated	Max.	Rated	Max.	
12k	9.52(3/8)	6.35(1/4)	5/16.4	20/65.6	0	8/26.2	15g/m (0.16oz/ft)
18k	12.7(1/2)	6.35(1/4)		25/82	0	10/32.8	
24k	15.9(5/8)	9.52(3/8)		25/82	0	10/32.8	

6. Capacity Tables

6.1 Cooling

		12k																	
INDOOR AIRFLOW (CMH)	OUT-DOOR DB (C)	ID WB (C)	16.0				18.0				19.0				22.0				
		ID DB (C)	23.0	25.0	27.0	29.0	23.0	25.0	27.0	29.0	23.0	25.0	27.0	29.0	23.0	25.0	27.0	29.0	
388	15	TC	3.57	3.59	3.59	3.61	3.79	3.85	3.85	3.85	3.90	3.90	3.90	3.90	4.19	4.19	4.19	4.19	
		S/T	0.70	0.77	0.84	0.91	0.57	0.64	0.71	0.78	0.51	0.58	0.65	0.71	0.38	0.44	0.50	0.56	
		PI	0.88	0.88	0.88	0.88	0.87	0.87	0.87	0.87	0.87	0.87	0.87	0.87	0.87	0.87	0.87	0.87	0.87
	20	TC	3.53	3.54	3.54	3.57	3.75	3.75	3.75	3.75	3.86	3.86	3.86	3.86	4.15	4.15	4.15	4.15	
		S/T	0.70	0.77	0.84	0.91	0.57	0.64	0.71	0.78	0.51	0.58	0.65	0.71	0.38	0.44	0.50	0.56	
		PI	0.91	0.91	0.91	0.91	0.90	0.90	0.90	0.90	0.90	0.90	0.90	0.90	0.90	0.90	0.90	0.90	0.90
	25	TC	3.37	3.37	3.37	3.40	3.57	3.57	3.57	3.57	3.69	3.69	3.69	3.69	3.98	3.98	3.98	3.98	
		S/T	0.70	0.78	0.86	0.93	0.57	0.65	0.72	0.79	0.51	0.58	0.65	0.72	0.37	0.44	0.50	0.57	
		PI	1.00	1.00	1.00	1.00	1.00	1.00	1.00	1.00	1.00	1.00	1.00	1.00	1.00	1.00	1.00	1.00	1.00
	30	TC	3.20	3.20	3.20	3.23	3.43	3.43	3.43	3.43	3.52	3.52	3.52	3.52	3.80	3.80	3.80	3.80	
		S/T	0.71	0.79	0.87	0.95	0.58	0.65	0.73	0.80	0.51	0.59	0.66	0.74	0.37	0.44	0.51	0.57	
		PI	1.10	1.10	1.10	1.10	1.10	1.10	1.10	1.10	1.10	1.10	1.10	1.10	1.11	1.11	1.11	1.11	
	35	TC	3.05	3.05	3.08	3.11	3.26	3.26	3.26	3.26	3.34	3.34	3.40	3.34	3.60	3.60	3.60	3.60	
		S/T	0.72	0.80	0.89	0.97	0.58	0.66	0.74	0.82	0.51	0.59	0.67	0.75	0.36	0.44	0.51	0.58	
		PI	1.19	1.19	1.19	1.19	1.20	1.20	1.20	1.20	1.20	1.20	1.20	1.20	1.21	1.21	1.21	1.21	
	40	TC	2.82	2.82	2.85	2.88	3.03	3.03	3.03	3.03	3.11	3.11	3.13	3.11	3.36	3.36	3.36	3.36	
		S/T	0.74	0.83	0.92	1.00	0.59	0.67	0.76	0.85	0.52	0.60	0.69	0.77	0.36	0.44	0.51	0.59	
		PI	1.37	1.37	1.37	1.37	1.38	1.38	1.38	1.38	1.38	1.38	1.38	1.38	1.39	1.39	1.39	1.39	
	43	TC	2.67	2.67	2.70	2.73	2.87	2.87	2.87	2.87	2.96	2.96	2.96	2.96	3.19	3.19	3.19	3.19	
		S/T	0.75	0.85	0.94	1.00	0.59	0.68	0.77	0.86	0.52	0.61	0.70	0.79	0.35	0.44	0.52	0.60	
		PI	1.47	1.47	1.47	1.47	1.48	1.48	1.48	1.48	1.48	1.48	1.48	1.48	1.49	1.49	1.49	1.49	
	482	15	TC	3.64	3.64	3.67	3.70	3.85	3.85	3.85	3.85	3.96	3.96	3.96	3.96	4.25	4.25	4.25	4.25
			S/T	0.73	0.82	0.90	0.99	0.58	0.67	0.75	0.84	0.52	0.60	0.68	0.76	0.36	0.44	0.51	0.59
			PI	0.90	0.90	0.90	0.90	0.89	0.89	0.89	0.89	0.89	0.89	0.89	0.89	0.90	0.90	0.90	0.90
20		TC	3.60	3.60	3.63	3.66	3.81	3.81	3.81	3.81	3.92	3.92	3.92	3.92	4.21	4.21	4.21	4.21	
		S/T	0.73	0.82	0.90	0.99	0.58	0.67	0.75	0.84	0.52	0.60	0.68	0.76	0.36	0.44	0.51	0.59	
		PI	0.93	0.93	0.93	0.93	0.92	0.92	0.92	0.92	0.92	0.92	0.92	0.92	0.92	0.92	0.92	0.92	
25		TC	3.43	3.43	3.46	3.49	3.63	3.63	3.63	3.63	3.75	3.75	3.75	3.75	4.04	4.04	4.04	4.04	
		S/T	0.74	0.83	0.92	1.00	0.59	0.68	0.77	0.86	0.52	0.60	0.69	0.78	0.36	0.44	0.52	0.60	
		PI	1.02	1.02	1.02	1.02	1.02	1.02	1.02	1.02	1.02	1.02	1.02	1.02	1.02	1.02	1.02	1.02	
30		TC	3.26	3.26	3.29	3.32	3.49	3.49	3.49	3.49	3.57	3.57	3.57	3.57	3.86	3.86	3.86	3.86	
		S/T	0.75	0.85	0.94	1.00	0.59	0.68	0.78	0.87	0.52	0.61	0.70	0.79	0.35	0.44	0.52	0.60	
		PI	1.12	1.12	1.12	1.12	1.12	1.12	1.12	1.12	1.12	1.12	1.12	1.12	1.13	1.13	1.13	1.13	
35		TC	3.11	3.11	3.14	3.17	3.32	3.32	3.32	3.34	3.40	3.40	3.46	3.40	3.66	3.66	3.66	3.66	
		S/T	0.76	0.86	0.96	1.00	0.60	0.70	0.79	0.89	0.52	0.62	0.71	0.81	0.35	0.44	0.53	0.61	
		PI	1.23	1.23	1.23	1.23	1.23	1.23	1.23	1.23	1.23	1.23	1.23	1.23	1.23	1.23	1.23	1.23	
40		TC	2.83	2.84	2.87	2.90	3.01	3.01	3.01	3.04	3.09	3.09	3.11	3.09	3.35	3.35	3.35	3.35	
		S/T	0.79	0.90	1.00	1.00	0.61	0.72	0.83	0.93	0.53	0.63	0.74	0.84	0.34	0.44	0.54	0.63	
		PI	1.40	1.40	1.40	1.40	1.40	1.40	1.40	1.40	1.40	1.40	1.41	1.40	1.41	1.41	1.41	1.41	
43		TC	2.68	2.71	2.73	2.76	2.85	2.85	2.85	2.88	2.93	2.93	2.93	2.93	3.19	3.19	3.19	3.19	
		S/T	0.80	0.91	1.00	1.00	0.62	0.73	0.84	0.95	0.53	0.64	0.75	0.86	0.34	0.44	0.54	0.64	
		PI	1.50	1.50	1.50	1.50	1.51	1.51	1.51	1.51	1.51	1.51	1.51	1.51	1.52	1.52	1.52	1.52	

Specifications

INDOOR AIRFLOW (CMH)	OUT-DOOR DB(C)	ID WB (C)	16.0				18.0				19.0				22.0			
			ID DB (C)	23.0	25.0	27.0	29.0	23.0	25.0	27.0	29.0	23.0	25.0	27.0	29.0	23.0	25.0	27.0
593	15	TC	3.70	3.70	3.73	3.76	3.90	3.90	3.90	3.93	4.02	4.02	4.02	4.02	4.33	4.33	4.33	4.33
		S/T	0.77	0.88	0.99	1.00	0.60	0.71	0.81	0.91	0.53	0.63	0.73	0.83	0.35	0.44	0.53	0.62
		PI	0.91	0.91	0.91	0.91	0.91	0.91	0.91	0.91	0.91	0.91	0.91	0.91	0.91	0.91	0.91	0.91
	20	TC	3.66	3.66	3.69	3.72	3.86	3.86	3.86	3.89	3.98	3.98	3.98	3.98	4.30	4.30	4.30	4.30
		S/T	0.77	0.88	0.99	1.00	0.60	0.71	0.81	0.91	0.53	0.63	0.73	0.83	0.35	0.44	0.53	0.62
		PI	0.94	0.94	0.94	0.94	0.94	0.94	0.94	0.94	0.94	0.94	0.94	0.94	0.93	0.93	0.93	0.93
	25	TC	3.49	3.52	3.55	3.57	3.69	3.69	3.69	3.72	3.81	3.81	3.81	3.81	4.09	4.09	4.09	4.09
		S/T	0.79	0.90	1.00	1.00	0.61	0.72	0.83	0.93	0.53	0.63	0.74	0.84	0.34	0.44	0.54	0.64
		PI	1.04	1.04	1.04	1.04	1.04	1.04	1.04	1.04	1.04	1.04	1.04	1.04	1.04	1.04	1.04	1.04
	30	TC	3.32	3.34	3.37	3.40	3.55	3.55	3.55	3.57	3.63	3.63	3.63	3.63	3.92	3.92	3.92	3.92
		S/T	0.80	0.92	1.00	1.00	0.62	0.73	0.84	0.95	0.53	0.64	0.75	0.86	0.34	0.44	0.54	0.65
		PI	1.14	1.14	1.14	1.14	1.14	1.14	1.14	1.14	1.15	1.15	1.15	1.15	1.15	1.15	1.15	1.15
	35	TC	3.14	3.17	3.20	3.23	3.37	3.37	3.37	3.40	3.46	3.46	3.52	3.46	3.75	3.75	3.75	3.75
		S/T	0.82	0.94	1.00	1.00	0.63	0.74	0.86	0.98	0.54	0.65	0.76	0.88	0.34	0.44	0.55	0.66
		PI	1.25	1.25	1.25	1.25	1.26	1.26	1.26	1.26	1.26	1.26	1.26	1.26	1.27	1.27	1.27	1.27
	40	TC	2.86	2.88	2.91	2.94	3.07	3.07	3.08	3.11	3.15	3.15	3.17	3.17	3.42	3.42	3.42	3.42
		S/T	0.85	0.98	1.00	1.00	0.64	0.77	0.90	1.00	0.55	0.67	0.80	0.92	0.33	0.45	0.57	0.90
		PI	1.42	1.42	1.42	1.42	1.43	1.43	1.43	1.43	1.43	1.43	1.43	1.43	1.44	1.44	1.44	1.44
	43	TC	2.71	2.73	2.76	2.79	2.90	2.90	2.93	2.96	2.99	2.99	2.99	3.02	3.25	3.25	3.25	3.25
		S/T	0.87	1.00	1.00	1.00	0.65	0.79	0.92	1.00	0.55	0.69	0.82	0.94	0.33	0.45	0.57	0.92
		PI	1.53	1.53	1.53	1.53	1.54	1.54	1.54	1.54	1.54	1.54	1.54	1.54	1.55	1.55	1.55	1.55

TC:Total Cooling Capacity (kW)
S/T:Sensible Cooling Capacity Ratio
PI:Power Input(kW)

18k																			
INDOOR AIRFLOW (CMH)	OUT-DOOR DB(C)	ID WB (C)	16.0				18.0				19.0				22.0				
		ID DB (C)	23.0	25.0	27.0	29.0	23.0	25.0	27.0	29.0	23.0	25.0	27.0	29.0	23.0	25.0	27.0	29.0	
508	15	TC	5.30	5.30	5.30	5.30	5.62	5.74	5.74	5.74	5.79	5.79	5.79	5.79	6.19	6.19	6.19	6.19	
		S/T	0.68	0.75	0.81	0.88	0.57	0.63	0.69	0.75	0.51	0.57	0.63	0.69	0.39	0.44	0.50	0.55	
		PI	1.31	1.31	1.31	1.31	1.31	1.31	1.31	1.31	1.31	1.31	1.31	1.31	1.30	1.30	1.30	1.30	
	20	TC	5.24	5.24	5.24	5.24	5.56	5.56	5.56	5.56	5.73	5.73	5.73	5.73	6.13	6.13	6.13	6.13	
		S/T	0.68	0.75	0.81	0.88	0.57	0.63	0.69	0.75	0.51	0.57	0.63	0.69	0.39	0.44	0.50	0.55	
		PI	1.36	1.35	1.35	1.36	1.35	1.35	1.35	1.35	1.35	1.35	1.35	1.35	1.34	1.34	1.34	1.34	
	25	TC	4.99	4.99	4.99	5.04	5.30	5.30	5.30	5.30	5.47	5.47	5.47	5.47	5.87	5.87	5.87	5.87	
		S/T	0.69	0.76	0.82	0.89	0.57	0.63	0.70	0.76	0.51	0.58	0.64	0.70	0.38	0.44	0.50	0.56	
		PI	1.50	1.50	1.50	1.50	1.49	1.49	1.49	1.49	1.49	1.49	1.49	1.49	1.50	1.50	1.50	1.50	
	30	TC	4.76	4.76	4.76	4.81	5.07	5.07	5.07	5.07	5.22	5.22	5.22	5.22	5.62	5.62	5.62	5.62	
		S/T	0.69	0.76	0.83	0.90	0.57	0.64	0.70	0.77	0.51	0.58	0.64	0.71	0.38	0.44	0.50	0.56	
		PI	1.63	1.63	1.63	1.63	1.63	1.63	1.63	1.63	1.64	1.64	1.64	1.64	1.64	1.64	1.64	1.64	
	35	TC	4.53	4.53	4.53	4.59	4.81	4.81	4.81	4.81	4.96	4.96	5.04	4.96	5.36	5.36	5.36	5.36	
		S/T	0.70	0.77	0.85	0.92	0.57	0.64	0.71	0.78	0.51	0.58	0.65	0.72	0.38	0.44	0.50	0.57	
		PI	1.79	1.79	1.79	1.79	1.79	1.79	1.79	1.79	1.80	1.80	1.80	1.80	1.81	1.81	1.81	1.81	
	40	TC	4.18	4.18	4.20	4.24	4.45	4.45	4.45	4.45	4.59	4.59	4.63	4.59	4.96	4.96	4.96	4.96	
		S/T	0.71	0.79	0.88	0.96	0.58	0.65	0.73	0.81	0.51	0.59	0.66	0.74	0.37	0.44	0.51	0.58	
		PI	2.04	2.04	2.04	2.04	2.05	2.05	2.05	2.05	2.06	2.06	2.06	2.06	2.07	2.07	2.07	2.07	
	43	TC	3.97	3.97	4.00	4.02	4.22	4.22	4.22	4.22	4.37	4.37	4.37	4.37	4.71	4.71	4.71	4.71	
		S/T	0.72	0.80	0.89	0.97	0.58	0.66	0.74	0.82	0.51	0.59	0.67	0.75	0.36	0.44	0.51	0.58	
		PI	2.19	2.19	2.19	2.19	2.20	2.20	2.20	2.20	2.21	2.21	2.21	2.21	2.23	2.23	2.23	2.23	
	669	15	TC	5.42	5.42	5.42	5.48	5.74	5.74	5.74	5.74	5.91	5.91	5.91	5.91	6.33	6.33	6.33	6.33
			S/T	0.71	0.80	0.88	0.96	0.58	0.66	0.73	0.81	0.51	0.59	0.67	0.74	0.37	0.44	0.51	0.58
			PI	1.33	1.33	1.33	1.33	1.34	1.34	1.34	1.34	1.34	1.34	1.34	1.34	1.33	1.33	1.33	1.33
20		TC	5.36	5.36	5.36	5.42	5.68	5.68	5.68	5.68	5.85	5.85	5.85	5.85	6.28	6.28	6.28	6.28	
		S/T	0.71	0.80	0.88	0.96	0.58	0.66	0.73	0.81	0.51	0.59	0.67	0.74	0.37	0.44	0.51	0.58	
		PI	1.38	1.38	1.38	1.38	1.38	1.38	1.38	1.38	1.38	1.38	1.38	1.38	1.37	1.37	1.37	1.37	
25		TC	5.10	5.10	5.16	5.22	5.42	5.42	5.42	5.42	5.59	5.59	5.59	5.59	6.02	6.02	6.02	6.02	
		S/T	0.72	0.81	0.89	0.98	0.58	0.66	0.75	0.83	0.51	0.59	0.67	0.75	0.36	0.44	0.51	0.58	
		PI	1.53	1.53	1.53	1.53	1.53	1.53	1.53	1.53	1.53	1.53	1.53	1.53	1.53	1.53	1.53	1.53	
30		TC	4.87	4.87	4.93	4.99	5.19	5.19	5.19	5.19	5.33	5.33	5.33	5.33	5.76	5.76	5.76	5.76	
		S/T	0.73	0.82	0.91	1.00	0.58	0.67	0.76	0.84	0.52	0.60	0.68	0.77	0.36	0.44	0.51	0.59	
		PI	1.67	1.67	1.67	1.67	1.67	1.67	1.67	1.67	1.67	1.67	1.67	1.67	1.68	1.68	1.68	1.68	
35		TC	4.62	4.62	4.67	4.73	4.93	4.93	4.93	4.93	5.07	5.07	5.16	5.07	5.48	5.48	5.48	5.48	
		S/T	0.74	0.84	0.93	1.00	0.59	0.68	0.77	0.86	0.52	0.61	0.69	0.78	0.35	0.44	0.52	0.60	
		PI	1.83	1.83	1.83	1.83	1.83	1.83	1.83	1.83	1.84	1.84	1.84	1.84	1.84	1.84	1.84	1.84	
40		TC	4.24	4.26	4.30	4.34	4.52	4.52	4.52	4.56	4.66	4.66	4.70	4.66	5.05	5.05	5.05	5.05	
		S/T	0.77	0.87	0.97	1.00	0.60	0.70	0.80	0.89	0.52	0.62	0.72	0.81	0.35	0.44	0.53	0.62	
		PI	2.09	2.09	2.09	2.09	2.09	2.09	2.09	2.09	2.10	2.10	2.10	2.10	2.12	2.12	2.12	2.12	
43		TC	4.03	4.06	4.09	4.11	4.29	4.29	4.29	4.34	4.43	4.43	4.43	4.43	4.80	4.80	4.80	4.80	
		S/T	0.78	0.88	0.99	1.00	0.61	0.71	0.81	0.91	0.53	0.63	0.73	0.83	0.35	0.44	0.53	0.62	
		PI	2.24	2.24	2.24	2.24	2.25	2.25	2.25	2.25	2.26	2.26	2.26	2.26	2.28	2.28	2.28	2.28	

INDOOR AIRFLOW (CMH)	OUT-DOOR DB(C)	ID WB (C)	16.0				18.0				19.0				22.0			
			ID DB (C)	23.0	25.0	27.0	29.0	23.0	25.0	27.0	29.0	23.0	25.0	27.0	29.0	23.0	25.0	27.0
781	15	TC	5.54	5.54	5.60	5.65	5.88	5.88	5.88	5.88	6.05	6.05	6.05	6.05	6.48	6.48	6.48	6.48
		S/T	0.74	0.84	0.93	1.00	0.59	0.68	0.77	0.86	0.52	0.60	0.69	0.78	0.36	0.44	0.52	0.60
		PI	1.37	1.37	1.37	1.37	1.36	1.36	1.36	1.36	1.37	1.37	1.37	1.37	1.36	1.36	1.36	1.36
	20	TC	5.48	5.48	5.53	5.59	5.82	5.82	5.82	5.82	5.99	5.99	5.99	5.99	6.42	6.42	6.42	6.42
		S/T	0.74	0.84	0.93	1.00	0.59	0.68	0.77	0.86	0.52	0.60	0.69	0.78	0.36	0.44	0.52	0.60
		PI	1.42	1.42	1.42	1.42	1.41	1.41	1.41	1.41	1.41	1.41	1.41	1.41	1.40	1.40	1.40	1.40
	25	TC	5.22	5.22	5.28	5.33	5.56	5.56	5.56	5.56	5.73	5.73	5.73	5.73	6.16	6.16	6.16	6.16
		S/T	0.75	0.85	0.95	1.00	0.59	0.69	0.78	0.88	0.52	0.61	0.70	0.79	0.35	0.44	0.52	0.61
		PI	1.56	1.56	1.56	1.56	1.56	1.56	1.56	1.56	1.56	1.56	1.56	1.56	1.56	1.56	1.56	1.56
	30	TC	4.99	4.99	5.05	5.10	5.30	5.30	5.30	5.36	5.45	5.45	5.45	5.45	5.88	5.88	5.88	5.88
		S/T	0.76	0.87	0.97	1.00	0.60	0.70	0.80	0.89	0.52	0.62	0.71	0.81	0.35	0.44	0.53	0.62
		PI	1.70	1.70	1.70	1.70	1.71	1.71	1.71	1.71	1.71	1.71	1.71	1.71	1.72	1.72	1.72	1.72
	35	TC	4.73	4.79	4.85	4.90	5.05	5.05	5.05	5.10	5.19	5.19	5.28	5.19	5.59	5.59	5.59	5.59
		S/T	0.78	0.88	0.98	1.00	0.61	0.71	0.81	0.91	0.53	0.63	0.72	0.83	0.35	0.44	0.53	0.63
		PI	1.87	1.87	1.87	1.87	1.87	1.87	1.87	1.87	1.88	1.88	1.88	1.88	1.89	1.89	1.89	1.89
	40	TC	4.34	4.38	4.42	4.46	4.64	4.64	4.64	4.69	4.78	4.78	4.81	4.78	5.16	5.16	5.16	5.16
		S/T	0.80	0.92	1.00	1.00	0.62	0.73	0.85	0.96	0.53	0.64	0.76	0.87	0.34	0.44	0.54	0.90
		PI	2.13	2.13	2.13	2.13	2.14	2.14	2.14	2.14	2.15	2.15	2.15	2.15	2.16	2.16	2.16	2.16
	43	TC	4.11	4.14	4.17	4.20	4.40	4.40	4.40	4.46	4.54	4.54	4.54	4.54	4.91	4.91	4.91	4.91
		S/T	0.82	0.94	1.00	1.00	0.63	0.74	0.86	0.97	0.54	0.65	0.77	0.88	0.34	0.44	0.55	0.92
		PI	2.29	2.29	2.29	2.29	2.30	2.30	2.30	2.30	2.31	2.31	2.31	2.31	2.33	2.33	2.33	2.33

TC:Total Cooling Capacity (kW)
S/T:Sensible Cooling Capacity Ratio
PI:Power Input(kW)

24k																			
INDOOR AIRFLOW (CMH)	OUT-DOOR DB(C)	ID WB (C)	16.0				18.0				19.0				22.0				
		ID DB (C)	23.0	25.0	27.0	29.0	23.0	25.0	27.0	29.0	23.0	25.0	27.0	29.0	23.0	25.0	27.0	29.0	
700	15	TC	7.09	7.08	7.08	7.08	7.51	7.66	7.66	7.66	7.74	7.74	7.74	7.74	8.28	8.28	8.28	8.28	
		S/T	0.69	0.75	0.82	0.89	0.57	0.63	0.69	0.76	0.51	0.57	0.64	0.70	0.39	0.44	0.50	0.56	
		PI	1.75	1.75	1.75	1.75	1.74	1.74	1.74	1.74	1.75	1.75	1.75	1.75	1.74	1.74	1.74	1.74	
	20	TC	7.01	7.00	7.00	7.00	7.43	7.43	7.43	7.43	7.66	7.66	7.66	7.66	8.21	8.21	8.21	8.21	
		S/T	0.69	0.75	0.82	0.89	0.57	0.63	0.69	0.76	0.51	0.57	0.64	0.70	0.39	0.44	0.50	0.56	
		PI	1.81	1.81	1.81	1.81	1.80	1.80	1.80	1.80	1.80	1.80	1.80	1.80	1.79	1.79	1.79	1.79	
	25	TC	6.69	6.69	6.69	6.74	7.09	7.09	7.09	7.09	7.32	7.32	7.32	7.32	7.86	7.86	7.86	7.86	
		S/T	0.69	0.76	0.83	0.90	0.57	0.64	0.70	0.77	0.51	0.58	0.64	0.70	0.38	0.44	0.50	0.56	
		PI	2.00	2.00	2.00	2.00	2.00	2.00	2.00	2.00	2.00	2.00	2.00	2.00	2.00	2.00	2.00	2.00	
	30	TC	6.37	6.37	6.37	6.43	6.77	6.77	6.77	6.77	6.97	6.97	6.97	6.97	7.52	7.52	7.52	7.52	
		S/T	0.70	0.77	0.84	0.91	0.57	0.64	0.71	0.78	0.51	0.58	0.65	0.71	0.38	0.44	0.50	0.56	
		PI	2.19	2.19	2.19	2.19	2.20	2.20	2.20	2.20	2.20	2.20	2.20	2.20	2.21	2.21	2.21	2.21	
	35	TC	6.06	6.06	6.06	6.11	6.43	6.43	6.43	6.43	6.63	6.63	6.74	6.63	7.17	7.17	7.17	7.17	
		S/T	0.70	0.78	0.86	0.93	0.57	0.65	0.72	0.79	0.51	0.58	0.65	0.72	0.37	0.44	0.50	0.57	
		PI	2.39	2.39	2.39	2.39	2.40	2.40	2.40	2.40	2.41	2.41	2.41	2.41	2.42	2.42	2.42	2.42	
	40	TC	5.58	5.58	5.62	5.67	5.94	5.94	5.94	5.94	6.14	6.14	6.18	6.14	6.63	6.63	6.63	6.63	
		S/T	0.72	0.80	0.88	0.96	0.58	0.66	0.74	0.82	0.51	0.59	0.67	0.75	0.36	0.44	0.51	0.58	
		PI	2.74	2.74	2.74	2.74	2.75	2.75	2.75	2.75	2.76	2.76	2.76	2.76	2.77	2.77	2.77	2.77	
	43	TC	5.29	5.29	5.35	5.40	5.63	5.63	5.63	5.63	5.83	5.83	5.83	5.83	6.29	6.29	6.29	6.29	
		S/T	0.73	0.81	0.90	0.98	0.58	0.66	0.75	0.83	0.51	0.59	0.68	0.76	0.36	0.44	0.51	0.59	
		PI	2.94	2.94	2.94	2.94	2.95	2.95	2.95	2.95	2.96	2.96	2.96	2.96	2.98	2.98	2.98	2.98	
	850	15	TC	7.23	7.23	7.23	7.29	7.66	7.66	7.66	7.66	7.89	7.89	7.89	7.89	8.46	8.46	8.46	8.46
			S/T	0.71	0.79	0.87	0.94	0.57	0.65	0.72	0.80	0.51	0.59	0.66	0.73	0.37	0.44	0.50	0.57
			PI	1.79	1.79	1.79	1.79	1.78	1.78	1.78	1.78	1.78	1.78	1.78	1.78	1.78	1.78	1.78	1.78
20		TC	7.15	7.15	7.15	7.21	7.58	7.58	7.58	7.58	7.81	7.81	7.81	7.81	8.38	8.38	8.38	8.38	
		S/T	0.71	0.79	0.87	0.94	0.57	0.65	0.72	0.80	0.51	0.59	0.66	0.73	0.37	0.44	0.50	0.57	
		PI	1.85	1.85	1.85	1.85	1.84	1.84	1.84	1.84	1.84	1.84	1.84	1.84	1.83	1.83	1.83	1.83	
25		TC	6.83	6.83	6.83	6.89	7.26	7.26	7.26	7.26	7.46	7.46	7.46	7.46	8.04	8.04	8.04	8.04	
		S/T	0.71	0.80	0.88	0.96	0.58	0.66	0.73	0.81	0.51	0.59	0.67	0.74	0.37	0.44	0.51	0.58	
		PI	2.04	2.04	2.04	2.04	2.04	2.04	2.04	2.04	2.04	2.04	2.04	2.04	2.04	2.04	2.04	2.04	
30		TC	6.52	6.52	6.57	6.63	6.92	6.92	6.92	6.92	7.12	7.12	7.12	7.12	7.69	7.69	7.69	7.69	
		S/T	0.72	0.81	0.89	0.98	0.58	0.66	0.74	0.83	0.51	0.59	0.67	0.75	0.36	0.44	0.51	0.58	
		PI	2.24	2.24	2.24	2.24	2.24	2.24	2.24	2.24	2.25	2.25	2.25	2.25	2.26	2.26	2.26	2.26	
35		TC	6.17	6.17	6.23	6.29	6.57	6.57	6.57	6.57	6.78	6.78	6.89	6.78	7.32	7.32	7.32	7.32	
		S/T	0.73	0.82	0.91	1.00	0.58	0.67	0.76	0.84	0.52	0.60	0.68	0.77	0.36	0.44	0.51	0.59	
		PI	2.44	2.44	2.44	2.44	2.45	2.45	2.45	2.45	2.46	2.46	2.46	2.46	2.46	2.46	2.46	2.46	
40		TC	5.64	5.64	5.70	5.76	6.01	6.01	6.01	6.04	6.21	6.21	6.25	6.21	6.71	6.71	6.71	6.71	
		S/T	0.75	0.85	0.95	1.00	0.59	0.69	0.78	0.88	0.52	0.61	0.70	0.80	0.35	0.44	0.52	0.61	
		PI	2.79	2.79	2.79	2.79	2.80	2.80	2.80	2.80	2.81	2.81	2.81	2.81	2.83	2.83	2.83	2.83	
43		TC	5.35	5.35	5.41	5.47	5.70	5.70	5.70	5.75	5.90	5.90	5.90	5.90	6.38	6.38	6.38	6.38	
		S/T	0.76	0.87	0.97	1.00	0.60	0.70	0.80	0.89	0.52	0.62	0.71	0.81	0.35	0.44	0.53	0.61	
		PI	3.00	3.00	3.00	3.00	3.01	3.01	3.01	3.01	3.02	3.02	3.02	3.02	3.05	3.05	3.05	3.05	

INDOOR AIRFLOW (CMH)	OUT-DOOR DB(C)	ID WB (C)	16.0				18.0				19.0				22.0			
			ID DB (C)	23.0	25.0	27.0	29.0	23.0	25.0	27.0	29.0	23.0	25.0	27.0	29.0	23.0	25.0	27.0
1050	15	TC	7.40	7.40	7.49	7.58	7.83	7.83	7.83	7.83	8.06	8.06	8.06	8.06	8.66	8.66	8.66	8.66
		S/T	0.74	0.84	0.93	1.00	0.59	0.68	0.77	0.86	0.52	0.61	0.69	0.78	0.35	0.44	0.52	0.60
		PI	1.83	1.83	1.83	1.83	1.82	1.82	1.82	1.82	1.81	1.81	1.81	1.81	1.82	1.82	1.82	1.82
	20	TC	7.32	7.32	7.41	7.49	7.75	7.75	7.75	7.75	7.98	7.98	7.98	7.98	8.58	8.58	8.58	8.58
		S/T	0.74	0.84	0.93	1.00	0.59	0.68	0.77	0.86	0.52	0.61	0.69	0.78	0.35	0.44	0.52	0.60
		PI	1.89	1.89	1.89	1.89	1.88	1.88	1.88	1.88	1.87	1.87	1.87	1.87	1.87	1.87	1.87	1.87
	25	TC	6.98	6.98	7.03	7.09	7.41	7.41	7.41	7.41	7.64	7.64	7.64	7.64	8.21	8.21	8.21	8.21
		S/T	0.75	0.85	0.95	1.00	0.59	0.69	0.78	0.88	0.52	0.61	0.70	0.80	0.35	0.44	0.52	0.61
		PI	2.08	2.08	2.08	2.08	2.08	2.08	2.08	2.08	2.08	2.08	2.08	2.08	2.08	2.08	2.08	2.08
	30	TC	6.63	6.63	6.69	6.75	7.06	7.06	7.06	7.12	7.29	7.29	7.29	7.29	7.84	7.84	7.84	7.84
		S/T	0.76	0.87	0.97	1.00	0.60	0.70	0.80	0.90	0.52	0.62	0.72	0.81	0.35	0.44	0.53	0.62
		PI	2.27	2.27	2.27	2.27	2.28	2.28	2.28	2.28	2.28	2.28	2.28	2.28	2.29	2.29	2.29	2.29
	35	TC	6.32	6.37	6.43	6.49	6.72	6.72	6.72	6.78	6.92	6.92	7.03	6.92	7.46	7.46	7.46	7.46
		S/T	0.78	0.89	0.99	1.00	0.61	0.71	0.82	0.92	0.53	0.63	0.73	0.83	0.35	0.44	0.53	0.63
		PI	2.49	2.49	2.49	2.49	2.50	2.50	2.50	2.50	2.51	2.51	2.51	2.51	2.52	2.52	2.52	2.52
	40	TC	5.77	5.82	5.88	5.94	6.15	6.15	6.15	6.21	6.33	6.33	6.37	6.37	6.85	6.85	6.85	6.85
		S/T	0.81	0.92	1.00	1.00	0.62	0.74	0.85	0.96	0.53	0.65	0.76	0.87	0.34	0.44	0.55	0.90
		PI	2.85	2.85	2.85	2.85	2.86	2.86	2.86	2.86	2.87	2.87	2.87	2.87	2.89	2.89	2.89	2.89
	43	TC	5.47	5.53	5.58	5.64	5.84	5.84	5.84	5.90	6.01	6.01	6.01	6.07	6.52	6.52	6.52	6.52
		S/T	0.82	0.94	1.00	1.00	0.63	0.75	0.87	0.98	0.54	0.66	0.77	0.88	0.34	0.44	0.55	0.92
		PI	3.06	3.06	3.06	3.06	3.07	3.07	3.07	3.07	3.08	3.08	3.08	3.08	3.11	3.11	3.11	3.11

TC:Total Cooling Capacity (kW)
S/T:Sensible Cooling Capacity Ratio
PI:Power Input(kW)

7. Capacity Correction Factor for Height Difference

Capacity(Btu/h)		12k		Pipe Length (m)			
		Cooling		5	10	15	20
Height difference H (m)	Indoor Upper than Outdoor	8		0.951	0.917	0.896	
		5	0.995	0.961	0.927	0.905	
	0	1.000	0.966	0.931	0.910		
	Outdoor Upper than Indoor	-5	1.000	0.966	0.931	0.910	
		-8		0.966	0.931	0.910	

Capacity(Btu/h)		18k		Pipe Length (m)			
		Cooling		5	10	15	25
Height difference H (m)	Indoor Upper than Outdoor	10		0.960	0.934	0.884	
		5	0.995	0.969	0.944	0.893	
	0	1.000	0.974	0.949	0.897		
	Outdoor Upper than Indoor	-5	1.000	0.974	0.949	0.897	
		-10		0.974	0.949	0.897	

Capacity(Btu/h)		24k		Pipe Length (m)			
		Cooling		5	10	15	25
Height difference H (m)	Indoor Upper than Outdoor	10		0.960	0.934	0.884	
		5	0.995	0.969	0.944	0.893	
	0	1.000	0.974	0.949	0.897		
	Outdoor Upper than Indoor	-5	1.000	0.974	0.949	0.897	
		-10		0.974	0.949	0.897	

8. Noise Criterion Curves

8.1 Indoor Unit

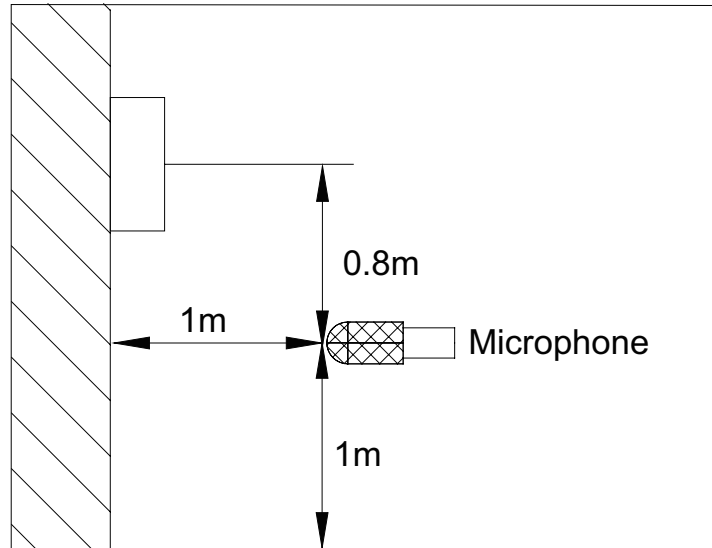

Notes:

- Sound measured at 1.0m away from the center of the unit.
- Data is valid at free field condition
- Data is valid at nominal operation condition
- Reference acoustic pressure $OdB = 20\mu Pa$
- Sound level will vary depending on a range of factors such as the construction -(acoustic absorption coefficient) of particular room in which the equipment is installed.
- The operating conditions are assumed to be standard.

12k

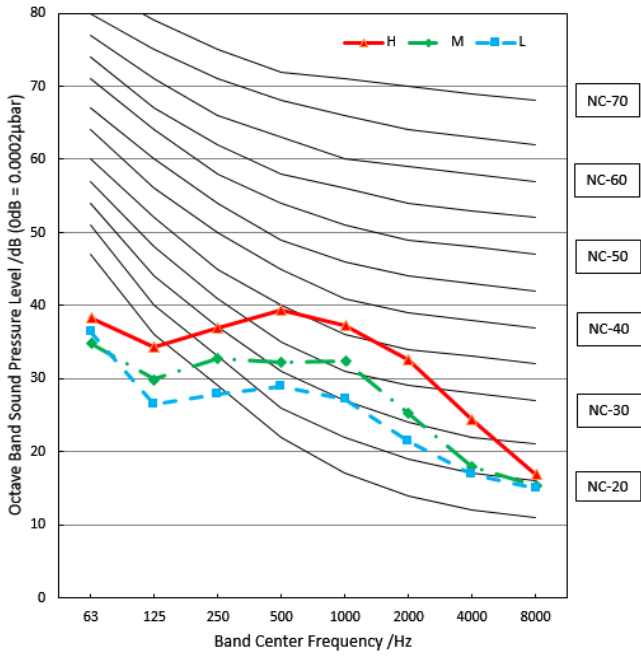

18k

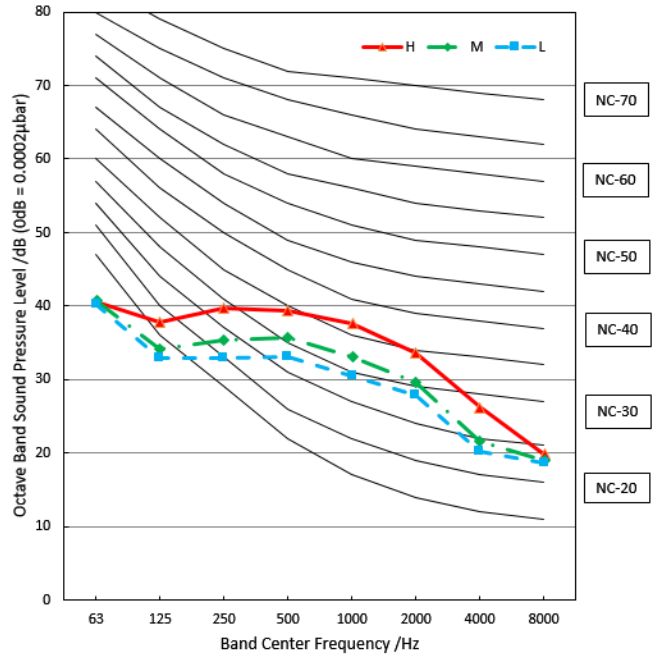

24k

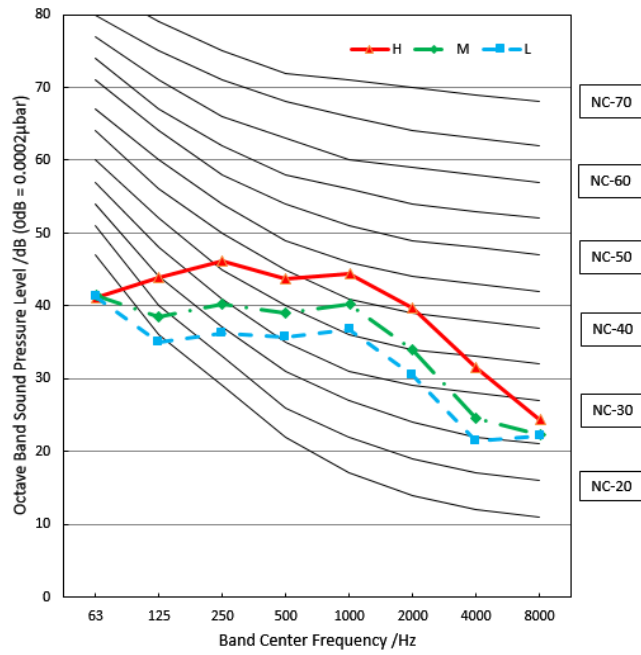

8.2 Outdoor Unit

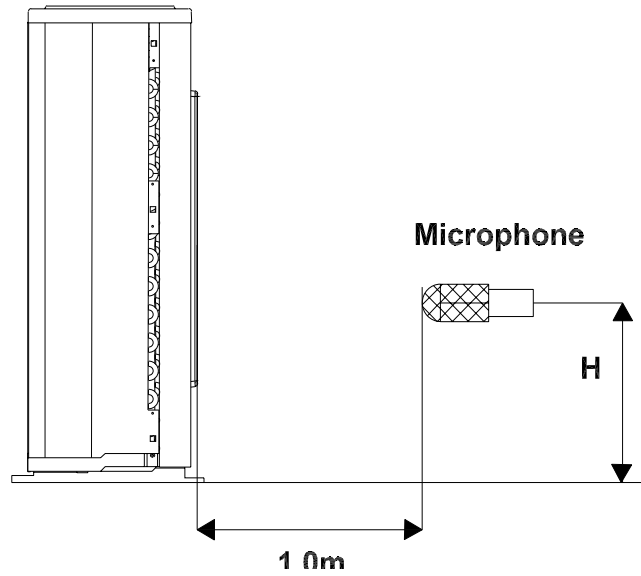

Note: $H = 0.5 \times$ height of outdoor unit

Notes:

- Sound measured at 1.0m away from the center of the unit.
- Data is valid at free field condition
- Data is valid at nominal operation condition
- Reference acoustic pressure $OdB=20\mu Pa$
- Sound level will vary depending on arrangement of factors such as the construction (acoustic absorption coefficient) of particular room in which the equipment is installed.
- The operating conditions are assumed to be standard.

12k

18k

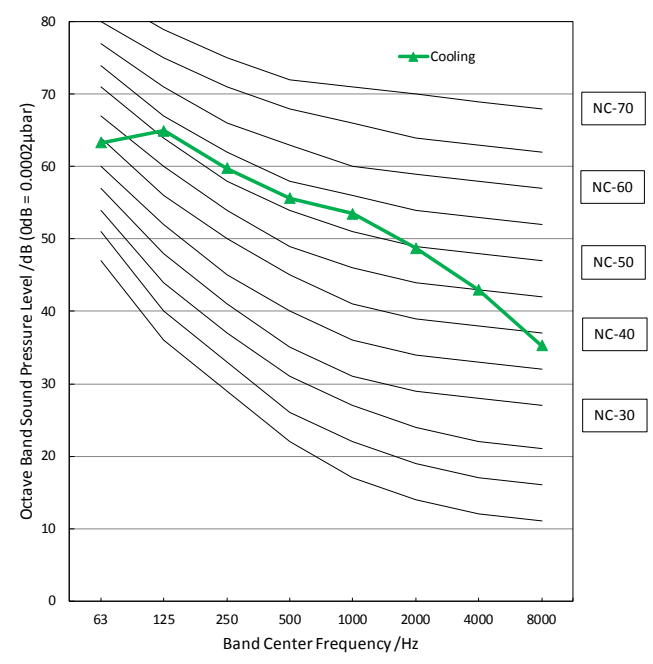
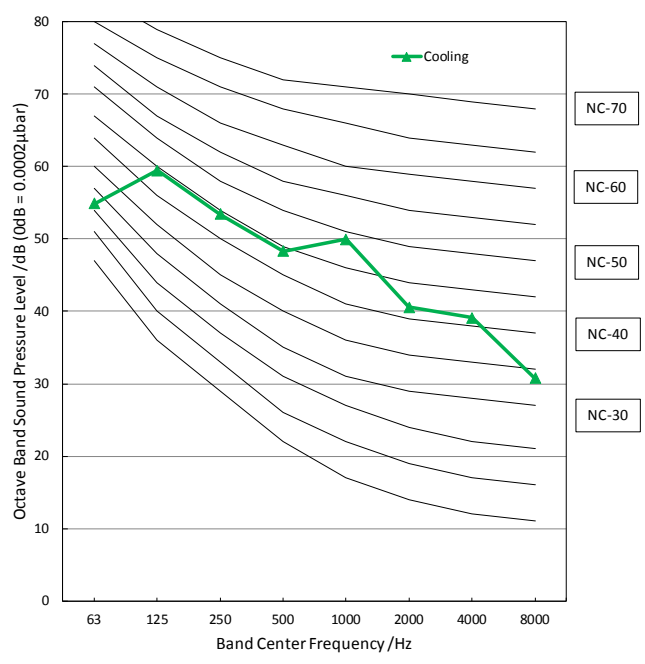

24k

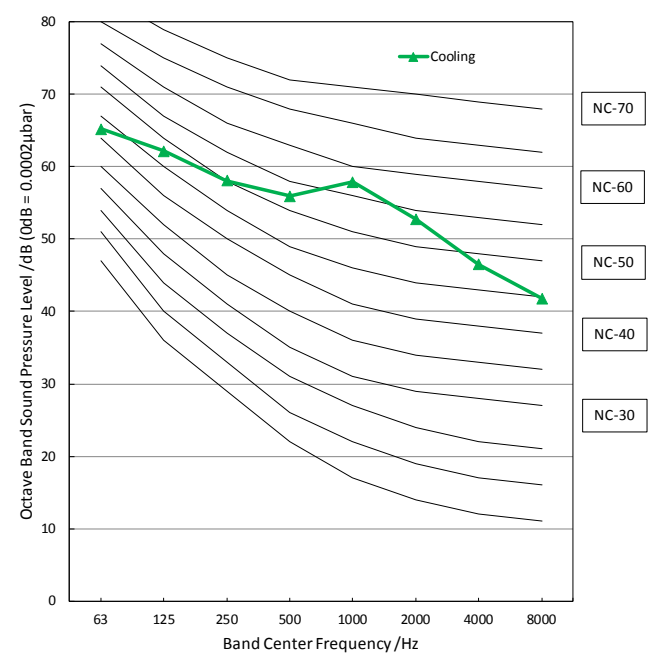

9. Electrical Characteristics

Model	Units			Power Supply			Compressor		OFM		
	Phase	Hz	Voltage	MCA	TOCA	MFA	MSC	RLA	Qty	kW	FLA
12k	1	60	220-230	7.125	9	10	28.5	5.55	1	0.021	0.288
18k			min:198	10.5	11.9	15	41.9	8.05	1	0.048	0.45
24k			max:253	14.25	17	25	58.0	10.55	1	0.063	0.6

Notes:

MCA: Minimum Circuit Amperes (A)

TOCA: Total Over-current Amps. (A)

MFA: Maximum Fuse Amperes (A)

MSC: Maximum Starting Current

RLA: Rated Load Amperes (A)

OFM: Outdoor Fan Motor

FLA: Full Load Amperes (A)

Product Features

Contents

1.	Operation Modes and Functions	29
1.1	Display Function	29
1.2	Abbreviation.....	30
1.3	Safety Features	30
1.4	Fan Mode.....	30
1.5	Cooling Mode	30
1.6	Heating Mode(Heat Pump Units)	30
1.7	Auto-mode.....	31
1.8	Drying Mode	31
1.9	Forced Operation Function	31
1.10	Auto-Restart Function.....	31
1.11	Refrigerant Leakage Detection	32
1.12	Self clean(Optional)	32
1.13	Follow me(Optional)	32
2.	Remote Controller Functions	32
2.1	Infrared Wireless Remote Controller.....	32

1. Operation Modes and Functions

1.1 Display Function

Unit display functions

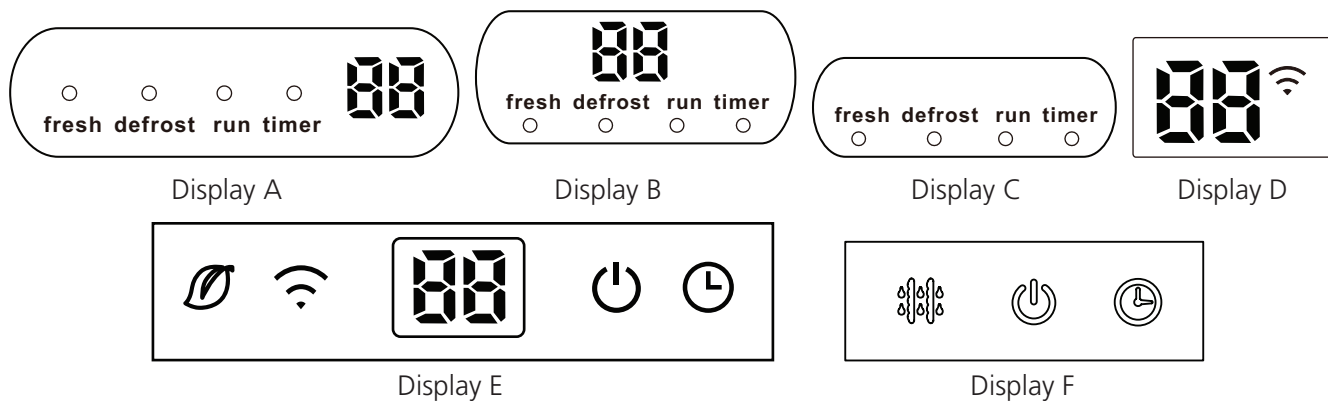

Display	Function
fresh or	Fresh(available on select units only)
defrost or	Defrost
run or	When the unit is on
timer or	When TIMER is on
	WiFi control (available on select units only)
	Temperature value
	Activation of Timer ON, Fresh, Swing, Turbo, or Silent
	Cancellation of Timer OFF, Fresh, Swing, Turbo, or Silent
	Defrost
	Warming in heating mode
	Self-clean (available on select units only)
	Heating in room temperature under 8°C
set temperature gradually illuminates to in one second intervals	ECO function (available on select units only)

Note: Please select the display function according to your purchase product.

1.2 Abbreviation

Unit element abbreviations

Abbreviation	Element
T1	Indoor room temperature
T2	Coil temperature of evaporator
T3	Coil temperature of condenser

1.3 Safety Features

Compressor three-minute delay at restart

Compressor functions are delayed for up to one minute upon the first startup of the unit, and are delayed for up to three minutes upon subsequent unit restarts.

Zero crossing detection error protection

If AC can not detect zero crossing signal for 4 minutes or the zero crossing signal time interval is not correct, the unit will stop and the LED will display the failure. The correct zero crossing signal time interval should be between 6-13ms.

Automatic shutoff based on fan speed

If the indoor fan speed registers below 300RPM for 50s, the unit ceases operation and the corresponding error code is displayed on the indoor unit.

Current protection

The current exceeds setting value for certain time, the compressor and outdoor fan will shut off.

Indoor fan delayed operation

- When the unit starts, the louver is automatically activated and the indoor fan will operate after a period of 4 seconds.
- If the unit is in heating mode, the indoor fan is regulated by the anti-cold wind function.

Sensor redundancy and automatic shutoff

If one temperature sensor malfunctions, the air conditioner ceases operation.

Refrigerant leakage detection

This function is active only when cooling mode is selected. It will detect if the compressor is being damaged by refrigerant leakage or by compressor overload. This is measured using the coil temperature of evaporator T2 when the compressor is in operation.

1.4 Fan Mode

When fan mode is activated:

- The outdoor fan and compressor are stopped.
- Temperature control is disabled and no temperature setting is displayed.
- The indoor fan speed can be set to high, medium, low, or auto.
- The louver operations are identical to those in cooling mode.
- Auto fan: In fan-only mode, AC operates the same as auto fan in cooling mode with the temperature set at 24°C.

1.5 Cooling Mode

1.5.1 Compressor Control

When indoor room temperature T1 is lower than setting value, the compressor and outdoor fan will shut off.

1.5.2 Indoor Fan Control

In cooling mode, the indoor fan operates continuously. The fan speed can be set to high, medium, low, or auto.

1.5.3 Outdoor Fan Control

For on-off models, outdoor units just have one single fan speed. The operation of outdoor fan is consistent with the operation of compressor, except the following situations.

- High temperature protection of condenser
- Current protection

1.5.4 Evaporator Temperature Protection

When evaporator temperature drops below a configured value, the compressor and outdoor fan ceases operations.

1.5.5 Condenser Temperature Protection (for some models)

When condenser temperature is more than setting value, the compressor will stop.

1.6 Heating Mode(for heat pump models)

1.6.1 Compressor Control

When indoor room temperature T1 is higher than setting value the compressor and outdoor fan will shut off.

1.6.2 Indoor Fan Control

- When the compressor is on, the indoor fan can be set to high/med/low/auto. And the anti-cold wind function has the priority.
- The indoor fan speed will adjust according to the value of T1-TS.

1.6.3 Outdoor Fan Control

For on-off models, outdoor units just have one single fan speed. The operation of outdoor fan is consistent with the operation of compressor, except the following situations.

- High temperature protection of evaporator
- Defrosting
- Current protection

1.6.4 Defrosting mode

- The unit enters defrosting mode according to the temperature difference between T2 and T1, as well as the compressor runtime.
- In defrosting mode, the compressor continues to run, the indoor and outdoor motor will cease operation, the defrost light of the indoor unit will turn on, and the “” symbol is displayed.
- If any one of the following conditions is satisfied, defrosting ends and the machine switches to normal heating mode:
 - Compressor current is over than I_{defrost} and lasts for 7s
 - The defrosting time has reached the setting value.
 - $T2 \geq 2^{\circ}\text{C}$ (3.6°F) after entering defrosting mode for 3 minutes.
 - After entering defrosting mode for 2 minutes, check the value of T2. The minimum temperature of T2 is marked as T2min. If $T2 - T2\text{min} \geq 2^{\circ}\text{C}$ (3.6°F) during the following 4 minutes, AC will exit defrosting mode (if $T2 \leq -15^{\circ}\text{C}$ (5°F), considers it as -15°C (5°F)).

1.6.5 Evaporator Temperature Protection

When the evaporator temperature exceeds a preset protection value, the compressor stops.

1.7 Auto-mode

- This mode can be selected with the remote controller.
- In auto mode, the machine selects cooling, heating, or fan-only mode on the basis of ΔT ($\Delta T = T1 - T_s$).

ΔT	Running mode
$\Delta T > 2^{\circ}\text{C}$	Cooling
$-3^{\circ}\text{C} \leq \Delta T \leq 2^{\circ}\text{C}$	Fan-only
$\Delta T < -3^{\circ}\text{C}$	Heating*

Heating*: In auto mode, cooling only models run the fan

- AC will run in auto mode in the below cases:

- Pressing the forced auto button.
- If AC is off, it will run in auto mode when the timer on function is active.
- After setting the mode, AC will run in auto mode if the compressor keeps not running for certain time.

1.8 Drying mode

- The compressor is cycled running with 10 minutes on and then 5 minutes off. The indoor fan will keep running at low speed.
- In drying mode, if room temperature is lower than 10°C , the compressor will stop and not resume until room temperature exceeds 13°C .
- The evaporator anti-freezing protection is the same as that in cooling mode.

1.9 Forced operation function

- Forced cooling mode:

The compressor and outdoor fan continue to run and the indoor fan runs at low speed. After running for 30 minutes, the AC will switch to auto mode with a preset temperature of 24°C .

- Forced auto mode:

Forced auto mode operates the same as normal auto mode with a preset temperature of 24°C .

- The unit exits forced operation when it receives the following signals:
 - Switch on
 - Switch off
 - Timer on
 - Timer off
 - Changes in:
 - mode
 - fan speed
 - sleeping mode

1.10 Auto-Restart function

- The indoor unit has an auto-restart module that allows the unit to restart automatically. The module automatically stores the current settings (not including the swing setting) and, in the case of a sudden power failure, will restore those setting automatically within 3 minutes after power returns.
- If the unit was in forced cooling mode, it will run in this mode for 30 minutes and turn to auto mode with

temperature set to 24°C.

- If there is a power failure while the unit is running, the compressor starts 3 minutes after the unit restarts. If the unit was already off before the power failure, the compressor starts 1 minute after the unit restarts.

1.11 Refrigerant Leakage Detection

- With this new technology, the display area will show "EC" when the outdoor unit detects refrigerant leakage.
- When compressor is active, the value of the Coil temperature of evaporator T2 has no change or very little change.

1.12 Self clean(Optional)

- If you press "Self Clean" when the unit is in cooling or drying mode:
 - For cooling models, the indoor unit will run in low fan mode for a certain time, then ceases operation.
 - For heat pump models, the indoor unit will run in fan-only mode, then low heat, and finally in fan-only mode.
- Self Clean keeps the indoor unit dry and prevents mold growth.

1.13 Follow me(Optional)

- If you press "Follow Me" on the remote, the indoor unit will beep. This indicates the follow me function is active.
- Once active, the remote control will send a signal every 3 minutes, with no beeps. The unit automatically sets the temperature according to the measurements from the remote control.
- The unit will only change modes if the information from the remote control makes it necessary, not from the unit's temperature setting.
- If the unit does not receive a signal for 7 minutes or you press "Follow Me," the function turns off. The unit regulates temperature based on its own sensor and settings.

2. Remote Controller Functions

2.1 Infrared Wireless Remote Controller

R51M/E(Standard)

Remote Controller Specifications

Model	R51M/E
Rated Voltage	3.0V (Dry batteries R03/LR03×2)
Reaching Distance	8m
Environment Temperature Range	-5 °C ~60 °C (23 °F ~140 °F)

Buttons and Functions

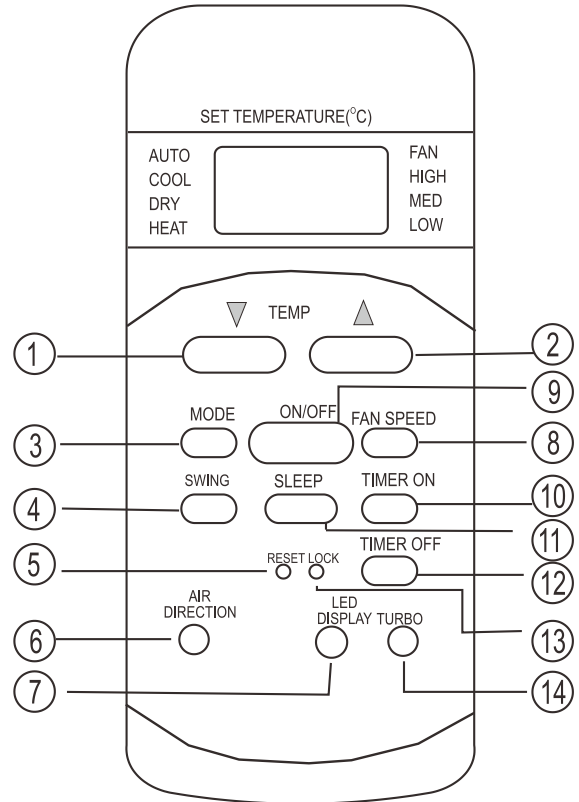

1. TEMP DOWN ▼ Button : Push this button to decrease the indoor temperature setting in 1 °C increments to 17 °C .

2. TEMP UP ▲ Button: Push this button to increase the indoor temperature setting in 1 °C increments to 30 °C

3. MODE Button: Once pressing, running mode will be selected in the following sequence:

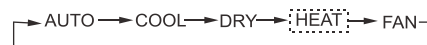

NOTE: No heating mode for cool only type unit.

4. SWING Button: Push this switch button to activate auto swing feature of the horizontal louver. Push it again to

stop.

5. RESET Button (inner located): Once the recessed RESET button is pressed, all of the current settings will be cancelled and the controller will return to the initial settings.

6. AIR DIRECTION Button: Press this button to change the swing angle of the louver. The swing angle of the louver is 6 degree for each press. When the louver swing at a certain angle which would affect the cooling and heating effect of the air conditioner, it would automatically change the swing direction . No symbol will appear in the display area when press this button. (Not applicable to units without this function).

7. LED DISPLAY Button: Press this button to clear the digit display in the air conditioner, press it again to activate it (Not available for the units without LED display window).

8. FAN SPEED Button: Fan speed will be selected in following sequence once pressing this button:

▶ AUTO → LOW → MED → HIGH]

9. ON/OFF Button: For turning on or turning off the air conditioner.

10. TIME ON Button: For time ON setting. Press this button to activate the Auto-on time setting. Each press will increase the time setting in 30 minutes increments, up to 10 hours, then at 1 hour increments up to 24 hours. To cancel the Auto-on time setting, just press the button until the time setting is 0.0.

11. SLEEP Button: Press this button to go into the Energy-Saving operation mode. Press it again to cancel. This function is only can be used on COOL, HEAT and AUTO mode and maintain the most comfortable temperature for you.

12. TIME OFF Button: For time OFF setting. Press this button to activate the Auto-off time setting. Each press will increase the time setting in 30 minutes increments, up to 10 hours, then at 1 hour increments up to 24 hours. To cancel the Auto-off time setting, just press the button until the time setting is 0.0.

13. LOCK Button(inner located): When you press the recessed LOCK button, all current settings are locked in and the remote controller does not accept any operation except that of the LOCK. Press again to cancel the LOCK mode.







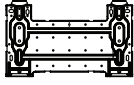
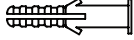

14. TURBO Button: Active/Disable Turbo function. Turbo function enables the unit to reach the preset temperature at cooling or heating operation in the shortest time(if the indoor unit does not support this function, there is no corresponding operation happened when pressing this button.)

Installation

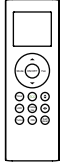
Contents

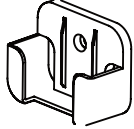
Accessories	35
1. Installation Overview	36
2. Location Selection	37
3. Indoor Unit Installation	39
4. Outdoor Unit Installation.....	44
5. Refrigerant Pipe Installation.....	45
6. Vacuum Drying and Leakage Checking.....	47
7. Additional Refrigerant Charge	48
8. Electrical and Gas Leak Checks	48
9. Test Operation	49

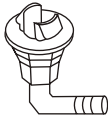
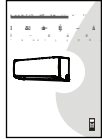
Accessories

Name	Shape	Quantity	
Mounting plate		1	
Clip anchor		5~8(depending on models)	
Mounting plate fixing screw ST3.9 X 25		5~8(depending on models)	
Remote controller		1	
Fixing screw for remote controller holder ST2.9 x 10		2	Optional Parts
Remote controller holder		1	
Dry battery AAA.LR03		2	
Seal		1(for cooling & heating models only)	
Drain joint			
Owner's manual&Installation manual		1	
Remote controller manual		1	
Small Filter(Need to be installed on the back of main air filter by the authorized technician while installing the machine)		1~2(depending on models)	
Connecting pipe assembly	Liquid side	Φ6.35 (1/4in)	Parts you must purchase. Consult the dealer about the pipe size.
		Φ9.52 (3/8in)	
	Gas side	Φ9.52 (3/8in)	
		Φ12.7 (1/2in)	
		Φ16 (5/8in)	
		Φ19 (3/4in)	

1. Installation Overview

Installation Order

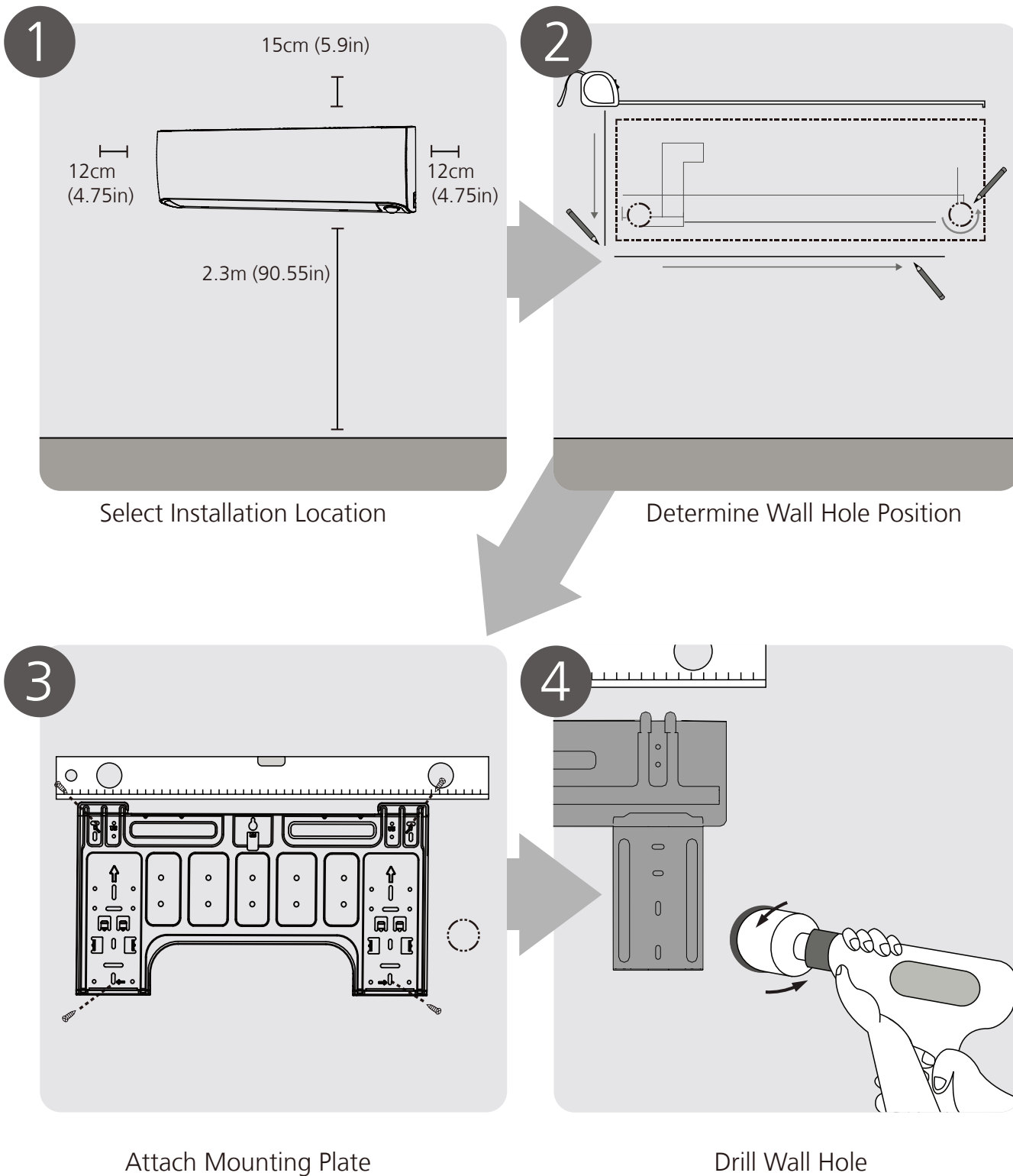

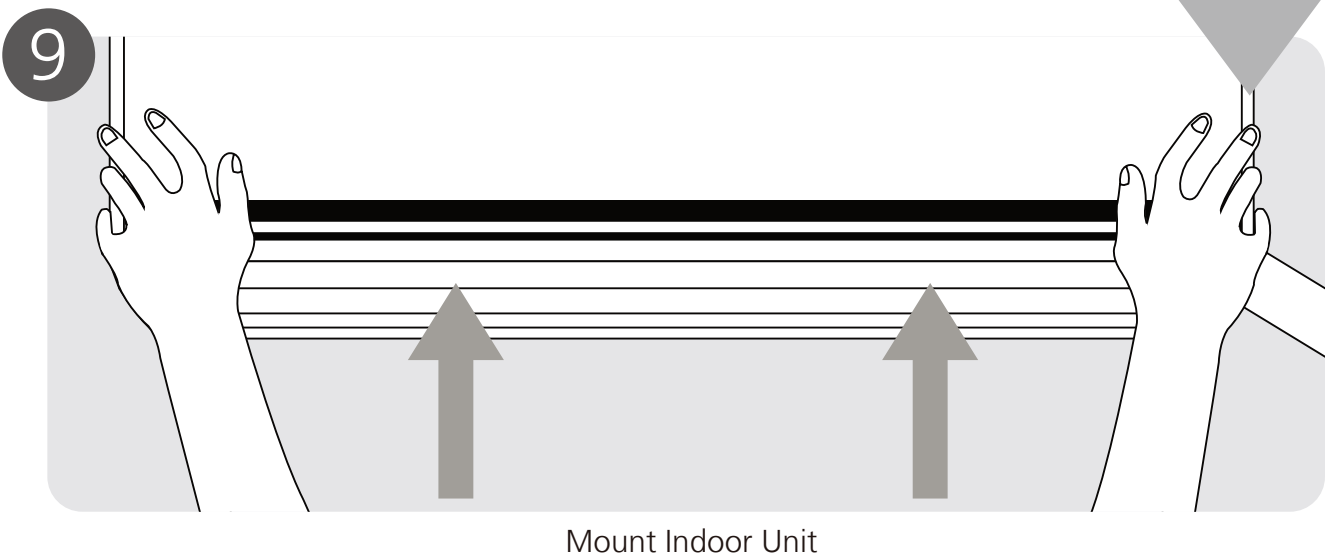
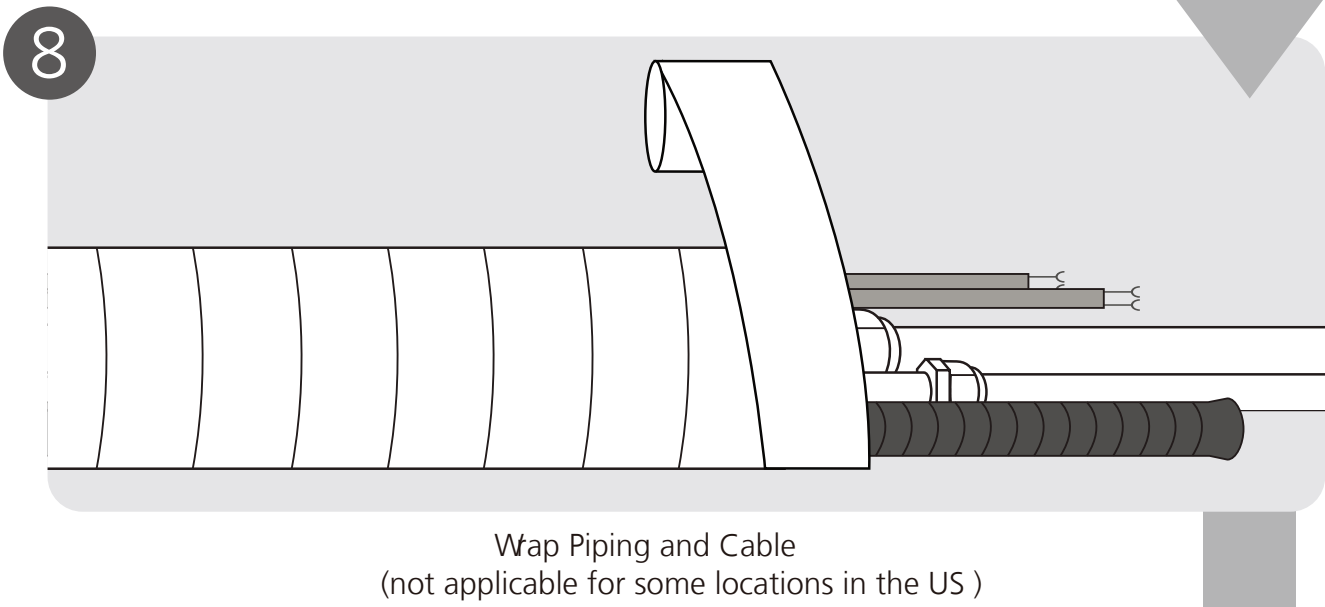
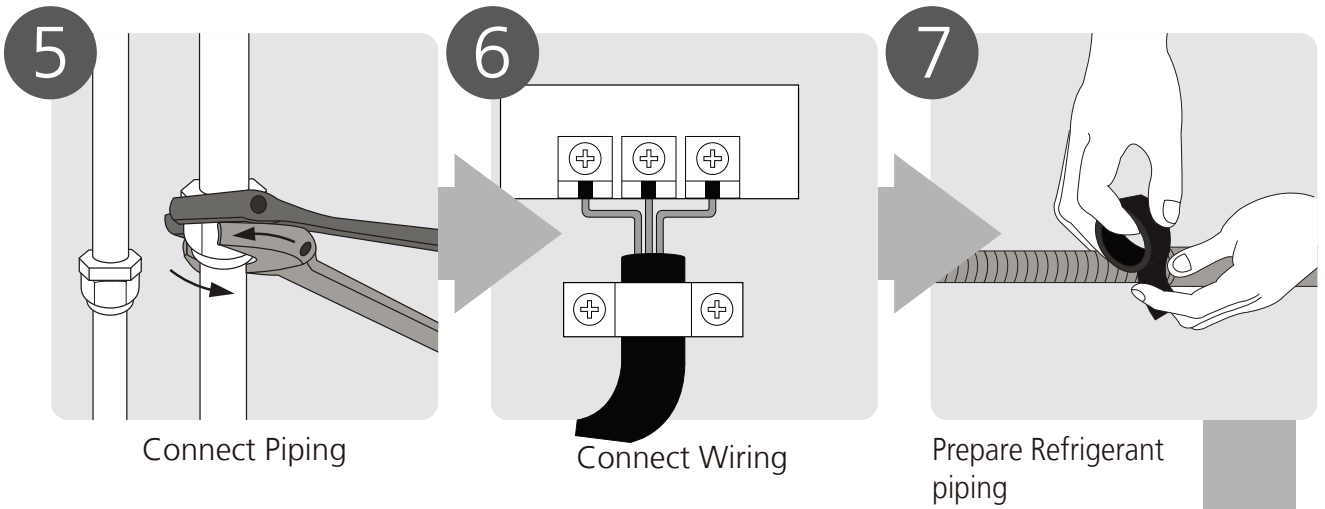

2. Location selection

2.1 Unit location selection can refer to installation manual.

2.2 **DO NOT** install the unit in the following locations:

- Where oil drilling or fracking is taking place.
- Coastal areas with high salt content in the air.
- Areas with caustic gases in the air, such as near hot springs.
- Areas with power fluctuations, such as factories.
- Enclosed spaces, such as cabinets.
- Areas with strong electromagnetic waves.
- Areas that store flammable materials or gas.
- Rooms with high humidity, such as bathrooms or laundry rooms.
- If possible, **DO NOT** install the unit where it is exposed to direct sunlight.

2.3 The minimum distance between the outdoor unit and walls described in the installation guide does not apply to airtight rooms. Be sure to keep the unit unobstructed in at least two of the three directions (M, N, P)

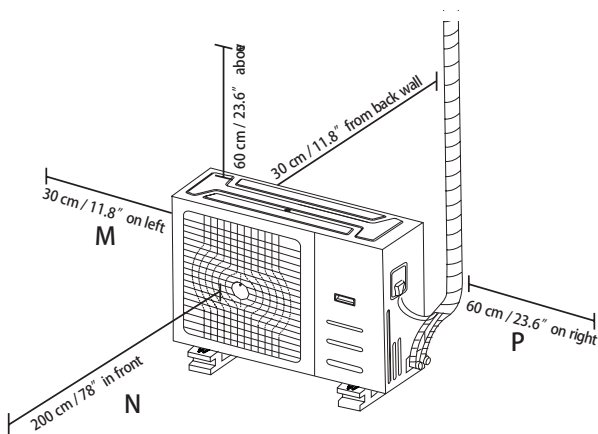

2.4 Rows of series installation

The relations between H, A and L are as follows.

	L	A
L ≤ H	$L \leq 1/2H$	25 cm / 9.8" or more
	$1/2H < L \leq H$	30 cm / 11.8" or more
L > H	Can not be installed	

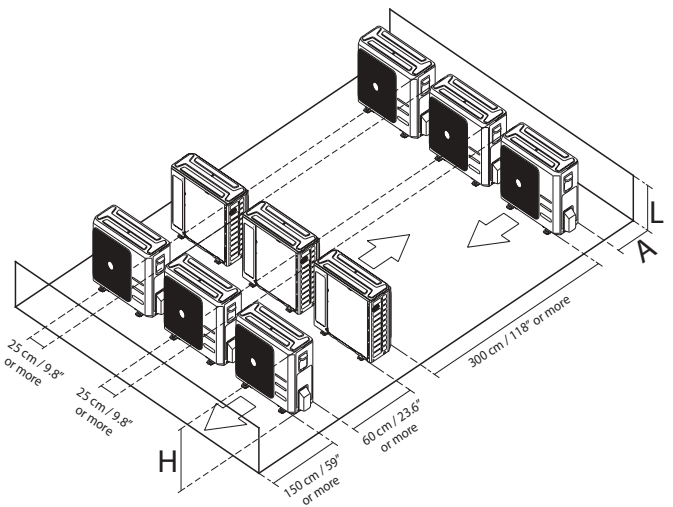

DO NOT install the rows of series like following figure.

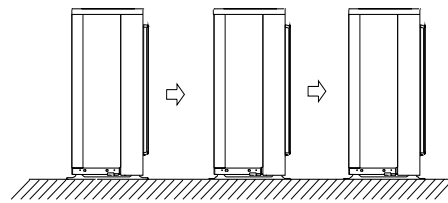

2.5 If the location is exposed to strong winds (for example: near a seaside), the unit must be placed against the wall to shelter it from the wind. If necessary, use an awning.

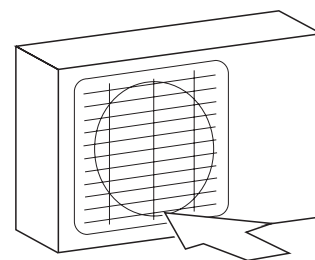

DO NOT Strong wind

3. Indoor Unit Installation

3.1 Service space for indoor unit

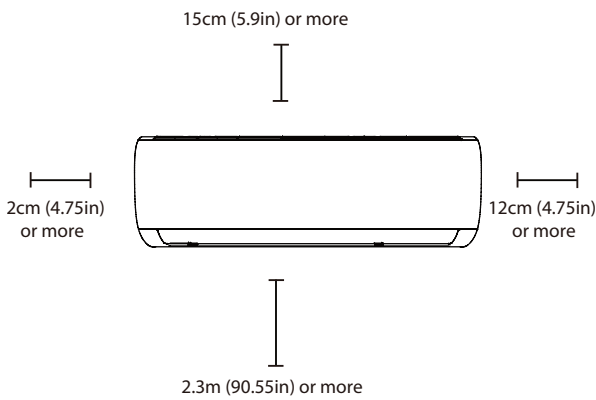

3.2 Attach mounting plate to wall

- **The mounting plate is the device on which you will mount the indoor unit.**

1. Remove the screw that attaches the mounting plate to the back of the indoor unit.
2. Place the mounting plate against the wall in a location that meets the standards in the Select Installation Location step. (See Mounting Plate Dimensions for detailed information on mounting plate sizes.)
3. Drill holes for mounting screws in places that:
 - have studs and can support the weight of the unit.
 - correspond to screw holes in the mounting plate.
4. Secure the mounting plate to the wall with the screws provided.
5. Make sure that mounting plate is flat against the wall.

- **Mounting plate dimensions**

Different models have different mounting plates. In order to ensure that you have ample room to mount the indoor unit, the diagrams to the right show different types of mounting plates along with the following dimensions:

1. Width of mounting plate
2. Height of mounting plate
3. Width of indoor unit relative to plate
4. Height of indoor unit relative to plate
5. Recommended position of wall hole (both to the left and right of mounting plate)
6. Relative distances between screw holes

Correct orientation of Mounting Plate

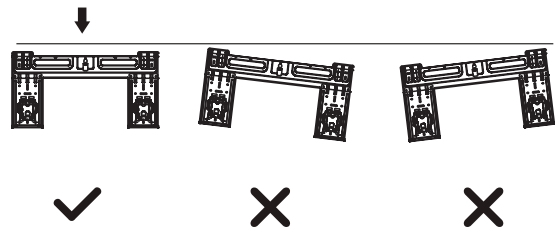

For Forest series:

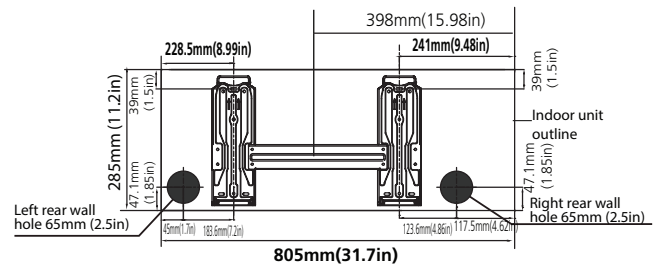

12k Models

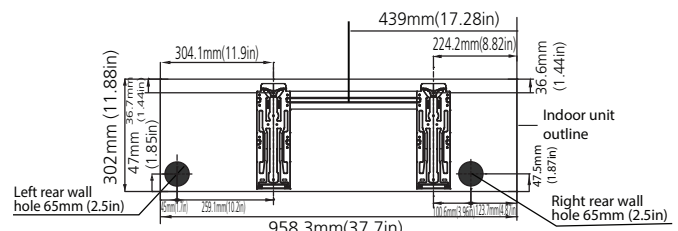

18k Model

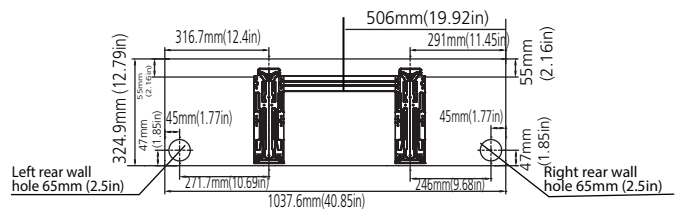

24k Model

3.3 Drill wall hole for connective piping

You must drill a hole in the wall for refrigerant piping, the drainage pipe, and the signal cable that will connect the indoor and outdoor units.

1. Determine the location of the wall hole based on the position of the mounting plate. Refer to Mounting Plate Dimensions.
2. Using a 65mm (2.5in) or 90mm (3.54in) (depending on models) core drill, drill a hole in the wall. Make sure that the hole is drilled at a slight downward angle, so that the outdoor end of the hole is lower than the indoor end by about 5mm to 7mm (0.2-0.27in). This will ensure proper water drainage.

3. Place the protective wall cuff in the hole. This protects the edges of the hole and will help seal it when you finish the installation process.

NOTE: When drilling the wall hole, make sure to avoid wires, plumbing, and other sensitive components.

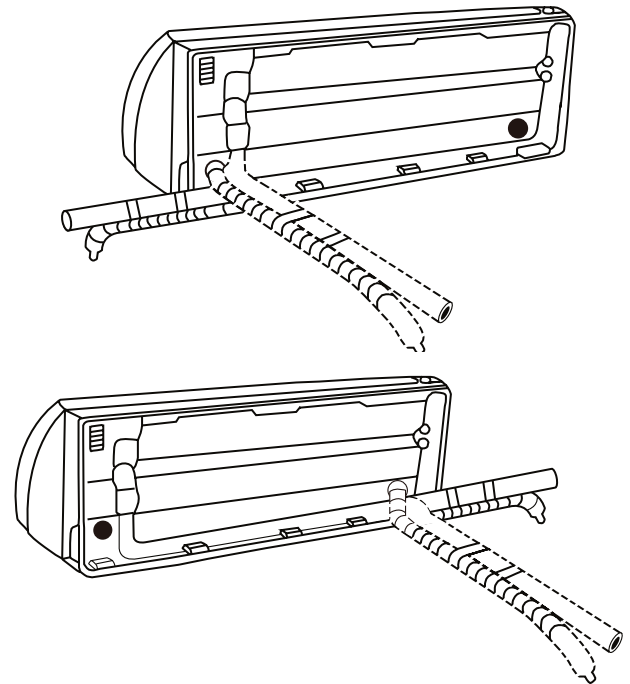
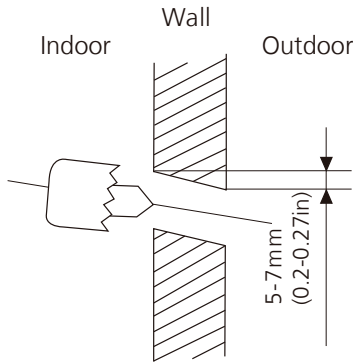

Be extremely careful not to dent or damage the piping while bending them away from the unit. Any dents in the piping will affect the unit's performance.

3.4 Prepare refrigerant piping

The refrigerant piping is inside an insulating sleeve attached to the back of the unit. You must prepare the piping before passing it through the hole in the wall.

1. Based on the position of the wall hole relative to the mounting plate, choose the side from which the piping will exit the unit.
2. If the wall hole is behind the unit, keep the knock-out panel in place. If the wall hole is to the side of the indoor unit, remove the plastic knock-out panel from that side of the unit.

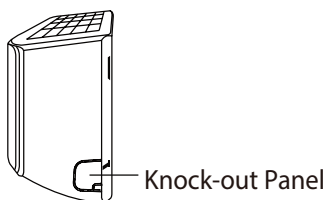

3. If existing connective piping is already embedded in the wall, proceed directly to the Connect Drain Hose step. If there is no embedded piping, connect the indoor unit's refrigerant piping to the connective piping that will join the indoor and outdoor units. Refer to the Refrigerant Piping Connection section of this manual for detailed instructions.

NOTE: Refrigerant piping can exit the indoor unit from four different angles:

- Left-hand side
- Left rear
- Right-hand side
- Right rear

3.5 Connect drain hose

By default, the drain hose is attached to the left hand side of unit (when you're facing the back of the unit).

- Wrap the connection point firmly with Teflon tape to ensure a good seal and to prevent leaks.
- Remove the air filter and pour a small amount of water into the drain pan to make sure that water flows from the unit smoothly.

NOTE ON DRAIN HOSE PLACEMENT:

- Make sure to arrange the drain hose according to the following figures.

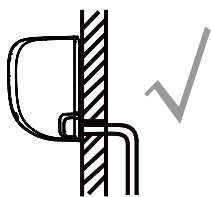

CORRECT

Make sure there are no kinks or dent in drain hose to ensure proper drainage.

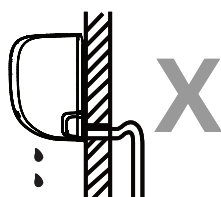

NOT CORRECT

Kinks in the drain hose will create water traps.

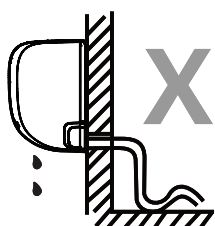

NOT CORRECT

Kinks in the drain hose will create water traps.

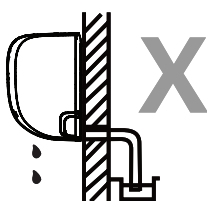

NOT CORRECT

Do not place the end of the drain hose in water or in containers that collect water. This will prevent proper drainage.

PLUG THE UNUSED DRAIN HOLE

To prevent unwanted leaks you must plug the unused drain hole with the rubber plug provided.

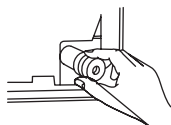

3.6 Connect signal and power cable

3.6.1 Before performing electrical work, read these regulations

1. All wiring must comply with local and national electrical codes, and must be installed by a licensed electrician.
2. All electrical connections must be made according to the Electrical Connection Diagram located on the panels of the indoor and outdoor units.
3. If there is a serious safety issue with the power supply, stop work immediately. Explain your reasoning to the client, and refuse to install the unit until the safety issue is properly resolved.
4. Power voltage should be within 90-110% of rated voltage. Insufficient power supply can cause malfunction, electrical shock, or fire.
5. If connecting power to fixed wiring, install a surge protector and main power switch with a capacity of 1.5 times the maximum current of the unit.
6. If connecting power to fixed wiring, a switch or circuit breaker that disconnects all poles and has a contact separation of at least 1/8in (3mm) must be incorporated in the fixed wiring. The qualified technician must use an approved circuit breaker or switch.
7. Only connect the unit to an individual branch circuit outlet. Do not connect another appliance to that outlet.
8. Make sure to properly ground the air conditioner.
9. Every wire must be firmly connected. Loose wiring can cause the terminal to overheat, resulting in product malfunction and possible fire.
10. Do not let wires touch or rest against refrigerant tubing, the compressor, or any moving parts within the unit.
11. If the unit has an auxiliary electric heater, it must be installed at least 1 meter (40in) away from any combustible materials.
12. BEFORE PERFORMING ANY ELECTRICAL OR WIRING WORK, TURN OFF THE MAIN POWER TO THE SYSTEM.

3.6.2 Connect signal and power cable

The signal cable enables communication between the indoor and outdoor units. You must first choose the right cable size before preparing it for connection.

Cable Types:

- Indoor Power Cable (if applicable): H05VV-F or H05V2V2-F
- Outdoor Power Cable: H07RN-F

- Signal Cable: H07RN-F

Table: Minimum Cross-Sectional Area able of Power and Signal Cables

Rated Current of Appliance (A)	Nominal Cross-Sectional Area (mm ²)
> 3 and ≤ 6	0.75
> 6 and ≤ 10	1
> 10 and ≤ 16	1.5
> 16 and ≤ 25	2.5
> 25 and ≤ 32	4
> 32 and ≤ 40	6

1. Prepare the cable for connection:

- Using wire strippers, strip the rubber jacket from both ends of signal cable to reveal about 40mm (1.57in) of the wires inside.
- Strip the insulation from the ends of the wires.
- Using wire crimper, crimp u-type lugs on the ends of the wires.

2. Open front panel of the indoor unit.

3. Using a screwdriver, open the wire box cover on the right side of the unit. This will reveal the terminal block.

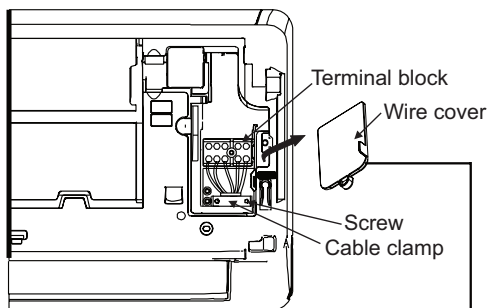

The Wiring Diagram is located on the inside of the indoor unit's wire cover.

4. Unscrew the cable clamp below the terminal block and place it to the side.

5. Facing the back of the unit, remove the plastic panel on the bottom left-hand side.

6. Feed the signal wire through this slot, from the back of the unit to the front.

7. Facing the front of the unit, match the wire colors with the labels on the terminal block, connect the u-lug and and firmly screw each wire to its corresponding terminal.

8. After checking to make sure every connection is secure,

use the cable clamp to fasten the signal cable to the unit. Screw the cable clamp down tightly.

9. Replace the wire cover on the front of the unit, and the plastic panel on the back.

NOTE:

- Choose the right cable size

The size of the power supply cable, signal cable, fuse, and switch needed is determined by the maximum current of the unit. The maximum current is indicated on the nameplate located on the side panel of the unit. Refer to this nameplate to choose the right cable, fuse, or switch.

- Take note of fuse specifications

The air conditioner's circuit board (PCB) is designed with a fuse to provide overcurrent protection. The specifications of the fuse are printed on the circuit board, such as: T3.15A/250VAC, T5A/250VAC, etc.

- Pay attention to live wire

While crimping wires, make sure you clearly distinguish the Live ("L") Wire from other wires.

- All wiring must performed strictly in accordance with the wiring diagram located on the back of the indoor units front panel.

- Do not mix up live and null wires.

This is dangerous, and can cause the air conditioning unit to malfunction.

- The wiring connection process may differ slightly between units.

3.7 Wrap piping and cables

Before passing the piping, drain hose, and the signal cable through the wall hole, you must bundle them together to save space, protect them, and insulate them.

1. Bundle the drain hose, refrigerant pipes, and signal cable according to the picture below:

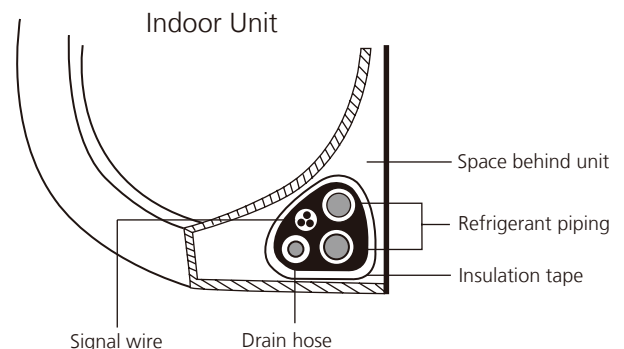

2. Using adhesive vinyl tape, attach the drain hose to the underside of the refrigerant pipes.

3. Using insulation tape, wrap the signal wire, refrigerant pipes, and drain hose tightly together. Double-check that all items are bundled in accordance with the picture above.

NOTE:

- Drain hose must be on bottom

Make sure that the drain hose is at the bottom of the bundle. Putting the drain hose at the top of the bundle can cause the drain pan to overflow, which can lead to fire or water damage.

- Do not intertwine signal cable with other wires

While bundling these items together, do not intertwine or cross the signal cable with any other wiring

- Do not wrap ends of piping

When wrapping the bundle, keep the ends of the piping unwrapped. You need to access them to test for leaks at the end of the installation process.

3.8 Mount indoor unit

3.8.1 If you installed new connective piping to the outdoor unit, do the following:

1. If you have already passed the refrigerant piping through the hole in the wall, proceed to **Prepare refrigerant piping**.
2. Otherwise, double-check that the ends of the refrigerant pipes are sealed to prevent dirt or foreign materials from entering the pipes.
3. Slowly pass the wrapped bundle of refrigerant pipes, drain hose, and signal wire through the hole in the wall.
4. Hook the top of the indoor unit on the upper hook of the mounting plate.
5. Check that unit is hooked firmly on mounting by applying slight pressure to the left and right-hand sides of the unit. The unit should not jiggle or shift.
6. Using even pressure, push down on the bottom half of the unit. Keep pushing down until the unit snaps onto the hooks along the bottom of the mounting plate.
7. Again, check that the unit is firmly mounted by applying slight pressure to the left and the right-hand sides of the unit.

3.8.2 If refrigerant piping is already embedded in the wall, do the following:

1. Hook the top of the indoor unit on the upper hook of the mounting plate.

- Unit is adjustable

Keep in mind that the hooks on the mounting plate are

smaller than the holes on the back of the unit. If you find that you don't have ample room to connect embedded pipes to the indoor unit, the unit can be adjusted left or right by about 30-50mm (1.25-1.95in), depending on the model.

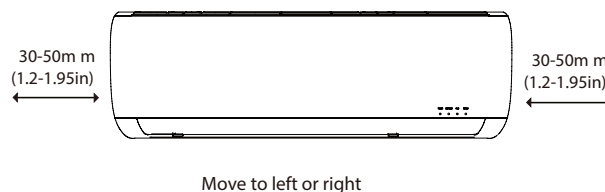

2. Use the holder in the mounting plate to prop up the unit, giving you enough room to connect the refrigerant piping, signal cable, and drain hose.

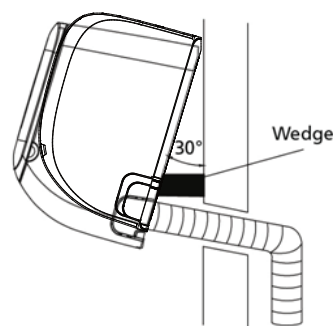

3. Connect drain hose and refrigerant piping (refer to Refrigerant Piping Connection section of this manual for instructions).
4. Keep pipe connection point exposed to perform the leak test (refer to Electrical Checks and Leak Checks section of this manual).
5. After the leak test, wrap the connection point with insulation tape.
6. Remove the bracket or wedge that is propping up the unit.
7. Using even pressure, push down on the bottom half of the unit. Keep pushing down until the unit snaps onto the hooks along the bottom of the mounting plate.

4. Outdoor unit installation(Side Discharge Unit)

4.1 Service space for outdoor unit

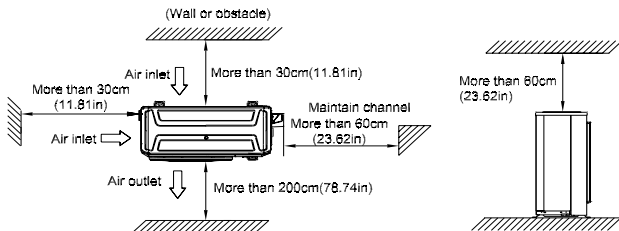

4.2 Bolt pitch

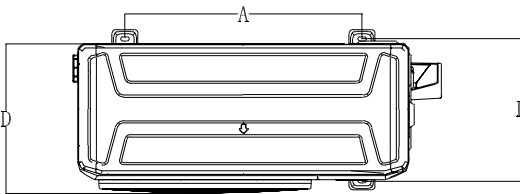

Capacity (Btu/h)	unit	A	B	D
12k	mm	460	292	285
	inch	18.11	11.5	11.22
18k	mm	487	298	300
	inch	19.17	11.73	11.81
24k	mm	540	350	363
	inch	21.26	13.78	14.29

4.3 Install Outdoor Unit

Fix the outdoor unit with anchor bolts(M10)

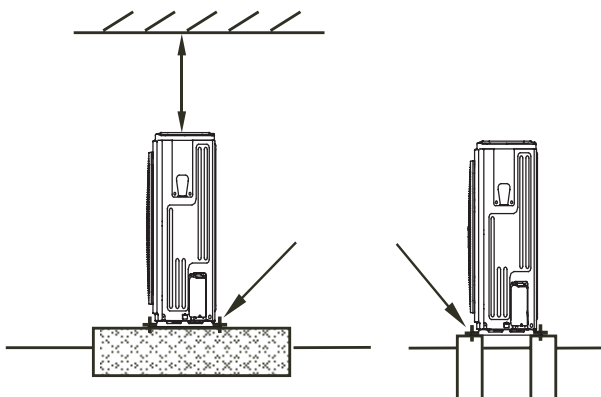

Cation

Since the gravity center of the unit is not at its physical center, so please be careful when lifting it with a sling.

Never hold the inlet of the outdoor unit to prevent it from deforming.

Do not touch the fan with hands or other objects.

Do not lean it more than 45°, and do not lay it sidelong.

Make concrete foundation according to the specifications of the outdoor units.

Fasten the feet of this unit with bolts firmly to prevent it from collapsing in case of earthquake or strong wind.

4.4 Install drain joint

Heat pump units require a drain joint. Before bolting the outdoor unit in place, you must install the drain joint at the bottom of the unit. Note that there are two different types of drain joints depending on the type of outdoor unit.

- **If the drain joint comes with a rubber seal (see Fig. A), do the following:**

1. Fit the rubber seal on the end of the drain joint that will connect to the outdoor unit.
2. Insert the drain joint into the hole in the base pan of the unit.
3. Rotate the drain joint 90° until it clicks in place facing the front of the unit.
4. Connect a drain hose extension (not included) to the drain joint to redirect water from the unit during heating mode.

- **If the drain joint doesn't come with a rubber seal (see Fig. B), do the following:**

1. Insert the drain joint into the hole in the base pan of the unit. The drain joint will click in place.
2. Connect a drain hose extension (not included) to the drain joint to redirect water from the unit during heating mode.

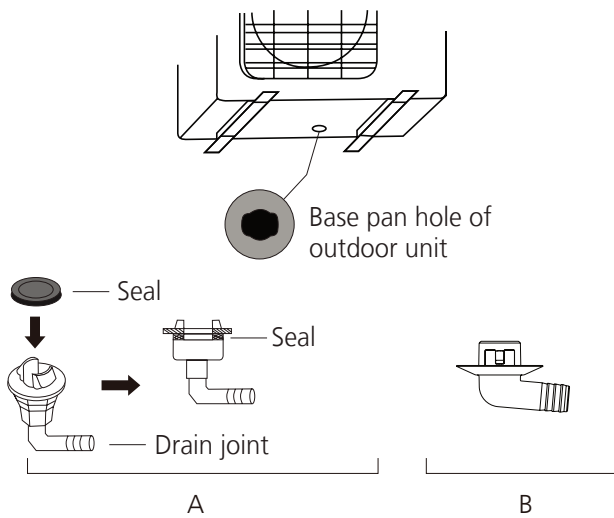

5. Refrigerant Pipe Installation

5.1 Maximum length and drop height

Ensure that the length of the refrigerant pipe, the number of bends, and the drop height between the indoor and outdoor units meets the requirements shown in the following table.

Capacity(kBtu/h)	Max. Length (m/ft)	Max. Elevation (m/ft)
12	20/65.6	8/26.2
18/24	25/82	10/32.8

caution:

- The capacity test is based on the standard length and the maximum permissible length is based on the system reliability.
- Oil traps

If the indoor unit is installed higher than the outdoor unit:

-If oil flows back into the outdoor unit's compressor, this might cause liquid compression or deterioration of oil return. Oil traps in the rising gas piping can prevent this.

An oil trap should be installed every 10m(32.8ft) of vertical suction line riser.

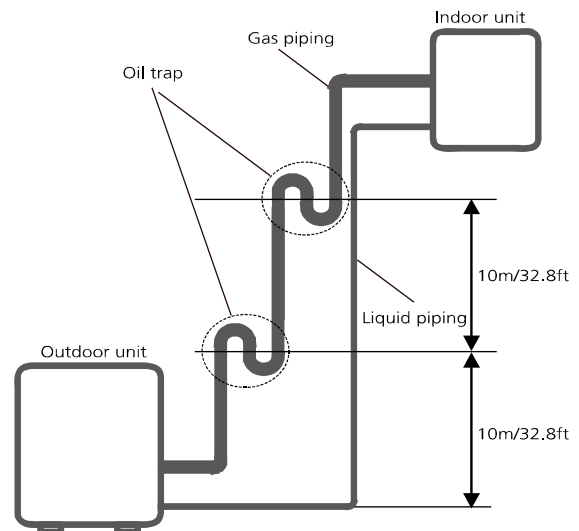

The indoor unit is installed higher than the outdoor unit

If the outdoor unit is installed higher than the indoor unit:

-It is recommended that vertical suction risers not be upsized. Proper oil return to the compressor should be maintained with suction gas velocity. If velocities drop below 7.62m/s(1500fpm (feet per minute)), oil return will be decreased. An oil trap should be installed every 6m(20ft) of vertical suction line riser.

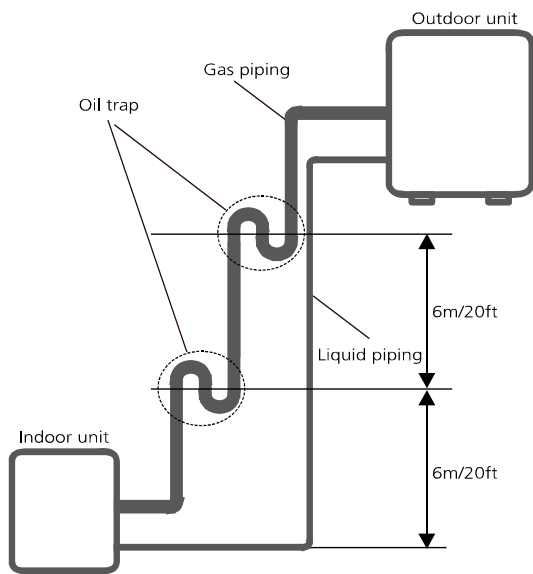

The outdoor unit is installed higher than the indoor unit.

5.2 The procedure of connecting pipes

1. Choose the pipe size according to the specification table.
2. Confirm the cross way of the pipes.
3. Measure the necessary pipe length.
4. Cut the selected pipe with pipe cutter
 - Make the section flat and smooth.

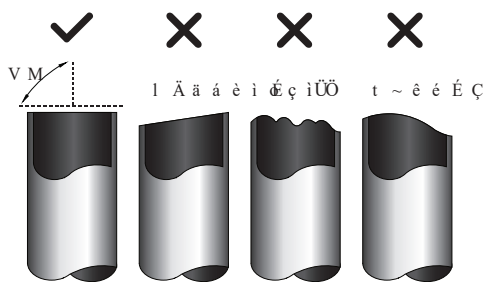

5. Insulate the copper pipe
 - Before test operation, the joint parts should not be heat insulated.
6. Flare the pipe
 - Insert a flare nut into the pipe before flaring the pipe
 - According to the following table to flare the pipe.

Outer diameter of pipe (inch(mm))	A (mm/inch)	
	Min	Max
1/4" (6.35)	0.7/0.0275	1.3/0.05
3/8" (9.52)	1.0/0.04	1.6/0.063
1/2" (12.7)	1.0/0.04	1.8/0.07
5/8" (15.9)	2.0/0.078	2.2/0.086
3/4" (19)	2.0/0.078	2.4/0.094

- After flared the pipe, the opening part must be seal by end cover or adhesive tape to avoid duct or exogenous impurity come into the pipe.
7. Drill holes if the pipes need to pass the wall.
 8. According to the field condition to bend the pipes so that it can pass the wall smoothly.
 9. Bind and wrap the wire together with the insulated pipe if necessary.
 10. Set the wall conduit
 11. Set the supporter for the pipe.
 12. Locate the pipe and fix it by supporter
 - For horizontal refrigerant pipe, the distance between supporters should not be exceed 1m.
 - For vertical refrigerant pipe, the distance between supporters should not be exceed 1.5m.
 13. Connect the pipe to indoor unit and outdoor unit by using two spanners.
 - Be sure to use two spanners and proper torque to fasten the nut, too large torque will damage the bellmouthing, and too small torque may cause leakage. Refer the following table for different pipe connection.

Pipe Diameter	Torque	Sketch map
	N.m(lb.ft)	
1/4" (6.35)	15~16 (11~11.8)	
3/8" (9.52)	25~26 (18.4~19.18)	
1/2" (12.7)	35~36 (25.8~26.55)	
5/8" (15.9)	45~47 (33.19~34.67)	
3/4" (19)	65~67 (47.94~49.42)	

6. Vacuum Drying and Leakage Checking

6.1 Purpose of vacuum drying

- Eliminating moisture in system to prevent the phenomena of ice-blockage and copper oxidation.

Ice-blockage shall cause abnormal operation of system, while copper oxide shall damage compressor.

- Eliminating the non-condensable gas (air) in system to prevent the components oxidizing, pressure fluctuation and bad heat exchange during the operation of system.

6.2 Selection of vacuum pump

- The ultimate vacuum degree of vacuum pump shall be -756mmHg or above.
- Precision of vacuum pump shall reach 0.02mmHg or above.

6.3 Operation procedure for vacuum drying

Due to different construction environment, two kinds of vacuum drying ways could be chosen, namely ordinary vacuum drying and special vacuum drying.

6.3.1 Ordinary vacuum drying

1. When conduct first vacuum drying, connect pressure gauge to the infusing mouth of gas pipe and liquid pipe, and keep vacuum pump running for 1 hour (vacuum degree of vacuum pump shall be reached -755mmHg).
2. If the vacuum degree of vacuum pump could not reach -755mmHg after 1 hour of drying, it indicates that there is moisture or leakage in pipeline system and need to go on with drying for half an hour.
3. If the vacuum degree of vacuum pump still could not reach -755mmHg after 1.5 hours of drying, check whether there is leakage source.
4. Leakage test: After the vacuum degree reaches -755mmHg, stop vacuum drying and keep the pressure for 1 hour. If the indicator of vacuum gauge does not go up, it is qualified. If going up, it indicates that there is moisture or leak source.

6.3.2 Special vacuum drying

The special vacuum drying method shall be adopted when:

1. Finding moisture during flushing refrigerant pipe.
2. Conducting construction on rainy day, because rain

water might penetrated into pipeline.

3. Construction period is long, and rain water might penetrated into pipeline.

4. Rain water might penetrate into pipeline during construction.

Procedures of special vacuum drying are as follows:

1. Vacuum drying for 1 hour.
2. Vacuum damage, filling nitrogen to reach 0.5Kgf/cm².

Because nitrogen is dry gas, vacuum damage could achieve the effect of vacuum drying, but this method could not achieve drying thoroughly when there is too much moisture. Therefore, special attention shall be drawn to prevent the entering of water and the formation of condensate water.

3. Vacuum drying again for half an hour.

If the pressure reached -755mmHg, start to pressure leakage test. If it cannot reached the value, repeat vacuum damage and vacuum drying again for 1 hour.

4. Leakage test: After the vacuum degree reaches -755mmHg, stop vacuum drying and keep the pressure for 1 hour. If the indicator of vacuum gauge does not go up, it is qualified. If going up, it indicates that there is moisture or leak source.

7. Additional Refrigerant Charge

- After the vacuum drying process is carried out, the additional refrigerant charge process need to be performed.
- The outdoor unit is factory charged with refrigerant. The additional refrigerant charge volume is decided by the diameter and length of the liquid pipe between indoor and outdoor unit. Refer the following formula to calculate the charge volume.

Diameter of liquid pipe (mm)	Formula
6.35	$V=12g/m \times (L-5)$
9.52	$V=24g/m \times (L-5)$

V: Additional refrigerant charge volume (g).

L : The length of the liquid pipe (m).

Note:

- Refrigerant may only be charged after performed the vacuum drying process.
- Always use gloves and glasses to protect your hands and eyes during the charge work.
- Use electronic scale or fluid infusion apparatus to weight refrigerant to be recharged. Be sure to avoid extra refrigerant charged, it may cause liquid hammer of the compressor or protections.
- Use supplementing flexible pipe to connect refrigerant cylinder, pressure gauge and outdoor unit. And The refrigerant should be charged in liquid state. Before recharging, The air in the flexible pipe and manifold gauge should be exhausted.
- After finished refrigerant recharge process, check whether there is refrigerant leakage at the connection joint part.(Using gas leakage detector or soap water to detect).

8. Electrical and Gas Leak Checks

8.1 Electrical Safety Checks

After installation, confirm that all electrical wiring is installed in accordance with local and national regulations, and according to the Installation Manual.

8.1.1 Before test run

• Check Grounding Work

Measure grounding resistance by visual detection and with grounding resistance tester. Grounding resistance must be less than 0.1 Ω .

Note: This may not be required for some locations in the US.

8.1.2 During test run

• Check for Electrical Leakage

During the Test Run, use an electroprobe and multimeter to perform a comprehensive electrical leakage test.

If electrical leakage is detected, turn off the unit immediately and call a licensed electrician to find and resolve the cause of the leakage.

Note: This may not be required for some locations in the US.

8.2 Gas Leak Checks

There are two different methods to check for gas leaks.

• Soap and Water Method

Using a soft brush, apply soapy water or liquid detergent to all pipe connection points on the indoor unit and outdoor unit. The presence of bubbles indicates a leak.

• Leak Detector Method

If using leak detector, refer to the device's operation manual for proper usage instructions.

8.3 After performing gas leak checks

After confirming that the all pipe connection points DO NOT leak, replace the valve cover on the outside unit.

9. Test Operation

9.1 Before test run:

Only perform test run after you have completed the following steps:

- Electrical Safety Checks – Confirm that the unit's electrical system is safe and operating properly
- Gas Leak Checks – Check all flare nut connections and confirm that the system is not leaking
- Confirm that gas and liquid (high and low pressure) valves are fully open

9.2 Test Run Instructions

You should perform the Test Run for at least 30 minutes.

1. Connect power to the unit.
2. Press the ON/OFF button on the remote controller to turn it on.
3. Press the MODE button to scroll through the following functions, one at a time:
 - COOL – Select lowest possible temperature
 - HEAT – Select highest possible temperature
4. Let each function run for 5 minutes, and perform the following checks:

List of Checks to Perform	PASS/FALL	
No electrical leakage		
Unit is properly grounded		
All electrical terminals properly covered		
Indoor and outdoor units are solidly installed		
All pipe connection points do not leak	Outdoor(2)	Outdoor(2)
Water drains properly from drain hose		
All piping is properly insulated		
Unit performs COOL function properly		
Unit performs HEAT function properly		
Indoor unit louvers rotate properly		
Indoor unit responds to remote controller		

5. After the Test Run is successfully completed, and you confirm that all checks points in List of Checks to Perform have PASSED, do the following:

- Using remote control, return unit to normal operating temperature.
- Using insulation tape, wrap the indoor refrigerant pipe connections that you left uncovered during the indoor unit installation process.

9.3 If ambient temperature is below 17°C (63°F)

You can't use the remote controller to turn on the COOL function when the ambient temperature is below 17°C. In this instance, you can use the MANUAL CONTROL button to test the COOL function.

1. Lift the front panel of the indoor unit, and raise it until it clicks in place.
2. The MANUAL CONTROL button is located on the right-hand side of the display box. Press it two times to select the COOL function.
3. Perform Test Run as normal.

