



SM_AURORA_60R410A_INVERTER_US_NB_180910

AURORA INVERTER SERIES

SERVICE MANUAL

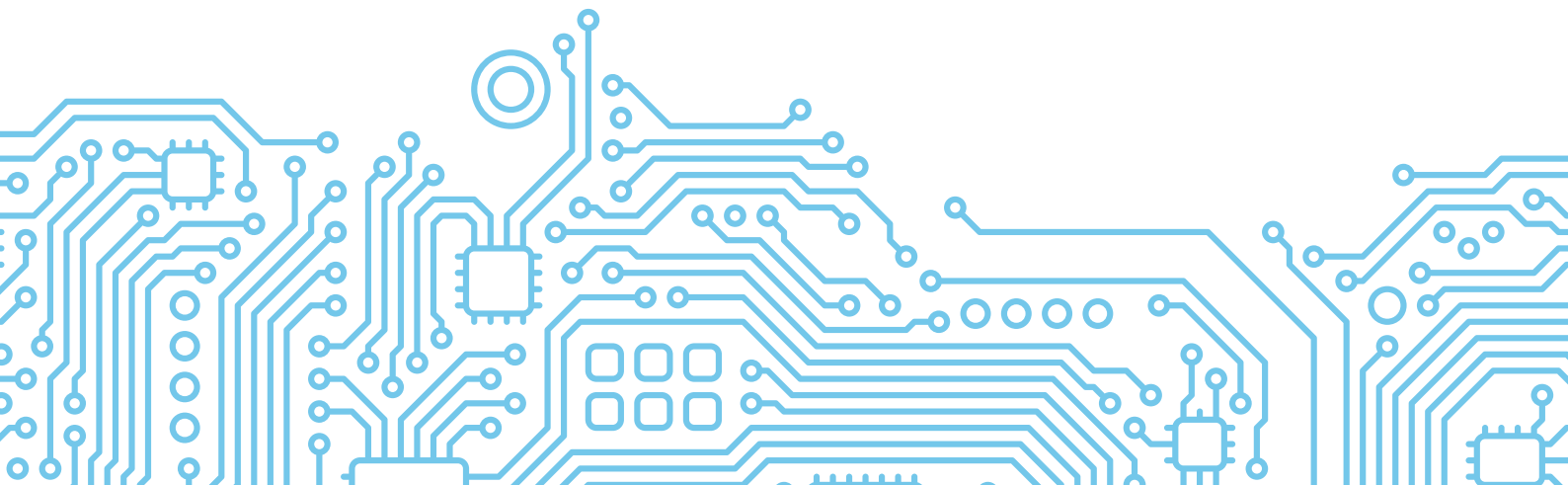
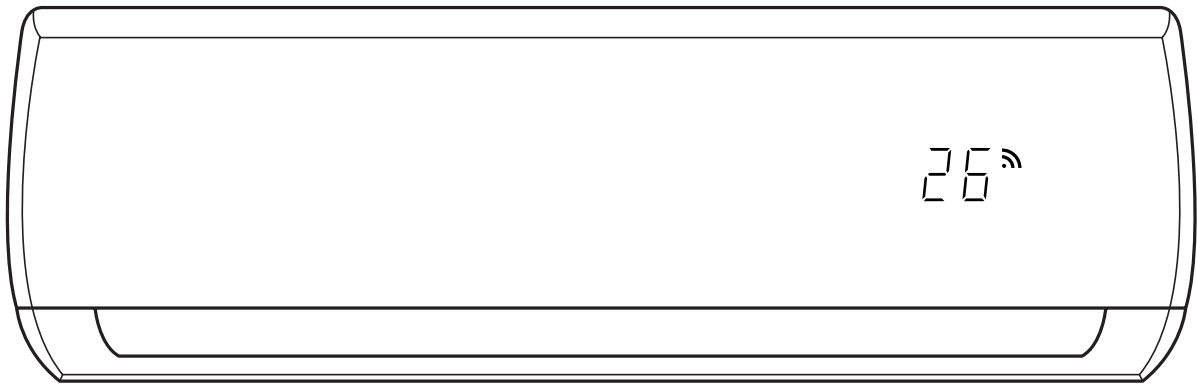

Table of Contents

Page

1. Safety Precautions	1
1. In case of Accidents or Emergency	
2. Pre-Installation and Installation	
3. Operation and Maintenance	
2. Specifications	3
1. Model Reference	
2. Electrical Wiring Diagrams	
3. Product Features	23
1. Operation Modes and Functions	
4. Maintenance and Disassembly	31
1. Maintenance	
2. Disassembly	
5. Troubleshooting	83
1. Safety Caution	
2. General Troubleshooting	
3. Error Diagnosis and Troubleshooting Without Error Code	
4. Quick Maintenance by Error Code	
5. Troubleshooting by Error Code	
Appendix	112
i) Temperature Sensor Resistance Value Table for T1,T2,T3 and T4 (°C – K)	
ii) Temperature Sensor Resistance Value Table for TP (°C – K)	
iii) $\Delta T(^{\circ}F)$	
iv) Pressure On Service Port	

Safety Precautions

Contents

1.	In Case of Accidents or Emergency	2
2.	Pre-Installation.....	2
3.	Operation and Maintenance.....	2

To prevent personal injury, or property or unit damage, adhere to all precautionary measures and instructions outlined in this manual. Before servicing a unit, refer to this service manual and its relevant sections.

Failure to adhere to all precautionary measures listed in this section may result in personal injury, damage to the unit or to property, or in extreme cases, death.

! **WARNING** indicates a potentially hazardous situation which if not avoided could result in serious personal injury, or death.

! **CAUTION** indicates a potentially hazardous situation which if not avoided could result in minor or moderate personal injury, or unit damage.

1. In case of Accidents or Emergency

! **WARNING**

- If a gas leak is suspected, immediately turn off the gas and ventilate the area if a gas leak is suspected before turning the unit on.
- If strange sounds or smoke is detected from the unit, turn the breaker off and disconnect the power supply cable.
- If the unit comes into contact with liquid, contact an authorized service center.
- If liquid from the batteries makes contact with skin or clothing, immediately rinse or wash the area well with clean water.
- Do not insert hands or other objects into the air inlet or outlet while the unit is plugged in.
- Do not operate the unit with wet hands.
- Do not use a remote controller that has previously been exposed to battery damage or battery leakage.

! **CAUTION**

- Clean and ventilate the unit at regular intervals when operating it near a stove or near similar devices.
- Do not use the unit during severe weather conditions. If possible, remove the product from the window before such occurrences.

2. Pre-Installation and Installation

! **WARNING**

- Use this unit only on a dedicated circuit.
- Damage to the installation area could cause the unit to fall, potentially resulting in personal injury, property damage, or product failure.
- Only qualified personnel should disassemble, install, remove, or repair the unit.
- Only a qualified electrician should perform electrical work. For more information, contact your dealer, seller, or an authorized service center.

! **CAUTION**

- While unpacking be careful of sharp edges around the unit as well as the edges of the fins on the condenser and evaporator.

3. Operation and Maintenance

! **WARNING**

- Do not use defective or under-rated circuit breakers.
- Ensure the unit is properly grounded and that a dedicated circuit and breaker are installed.
- Do not modify or extend the power cable. Ensure the power cable is secure and not damaged during operation.
- Do not unplug the power supply plug during operation.
- Do not store or use flammable materials near the unit.
- Do not open the inlet grill of the unit during operation.
- Do not touch the electrostatic filter if the unit is equipped with one.
- Do not block the inlet or outlet of air flow to the unit.
- Do not use harsh detergents, solvents, or similar items to clean the unit. Use a soft cloth for cleaning.
- Do not touch the metal parts of the unit when removing the air filter as they are very sharp.
- Do not step on or place anything on the unit or outdoor units.
- Do not drink water drained from the unit
- Avoid direct skin contact with water drained from the unit.
- Use a firm stool or step ladder according to manufacturer procedures when cleaning or maintaining the unit.

! **CAUTION**

- Do not install or operate the unit for an extended period of time in areas of high humidity or in an environment directly exposing it to sea wind or salt spray.
- Do not install the unit on a defective or damaged installation stand, or in an unsecure location.
- Ensure the unit is installed at a level position
- Do not install the unit where noise or air discharge created by the outdoor unit will negatively impact the environment or nearby residences.
- Do not expose skin directly to the air discharged by the unit for prolonged periods of time.
- Ensure the unit operates in areas water or other liquids.
- Ensure the drain hose is installed correctly to ensure proper water drainage.
- When lifting or transporting the unit, it is recommended that two or more people are used for this task.
- When the unit is not to be used for an extended time, disconnect the power supply or turn off the breaker.

Specifications

Contents

1.	Model Reference	4
2.	Electrical Wiring Diagrams	5
2.1	Indoor Unit.....	5
2.2	Outdoor Unit.....	7

1. Model Reference

Refer to the following table to determine the specific indoor and outdoor unit model number of your purchased equipment.

Indoor Unit Model	Outdoor Unit Model	Capacity (Btu)	Power Supply
MSABA-09CRDN1-BP0W	MOBA30-09CFN1-BP0W	9K	115V~, 60Hz, 1Phase
MSABA-09HRFN1-BQ0W	MOBA30-09HDN1-BQ0W		
MSABB-12CRDN1-BP0W	MOBA30-12CFN1-BP0W	12K	
MSABB-12HRFN1-BQ0W	MOBA30-12HDN1-BQ0W		
MSABA-09CRDN1-MP0W	MOBA30-09CFN1-MP0W	9K	208/230V~, 60Hz, 1Phase
MSABA-09HRFN1-MQ0W	MOBA30-09HDN1-MQ0W		
MSABB-12CRDN1-MP0W	MOBA30-12CFN1-MP0W	12K	
MSABB-12HRFN1-MQ0W	MOBA30-12HDN1-MQ0W		
MSABD-17CRFN1-MQ0W	MOB30-17CFN1-MQ0W	17K	
MSABD-18HRFN1-MQ0W	MOB30-18HDN1-MQ0W	18K	
MSABE-23CRDN1-MP0W	MOCA30-23CFN1-MP0W	22K	
MSABE-23HRFN1-MQ0W	MOCA30-23HDN1-MQ0W	24K	
MSABF-30HRFN1-MR0W	MOD30-30HFN1-MR0W	30K	
MSABF-36HRFN1-MP0W	MOD30-36HFN1-MP0W	36K	

2. Electrical Wiring Diagrams

2.1 Indoor unit

Abbreviation	Paraphrase
Y/G	Yellow-Green Conductor
ION	Positive and Negative Ion Generator
CAP	Capacitor
PLASMA	Electronic Dust Collector
L	LIVE
N	NEUTRAL
Heater	The Electric Heating Belt of Indoor Unit
T1	Indoor Room Temperature
T2	Coil Temperature of Indoor Heat Exchanger Middle

MSABA-09CRDN1-BP0W, MSABB-12CRDN1-BP0W, MSABA-09CRDN1-MP0W, MSABB-12CRDN1-MP0W:

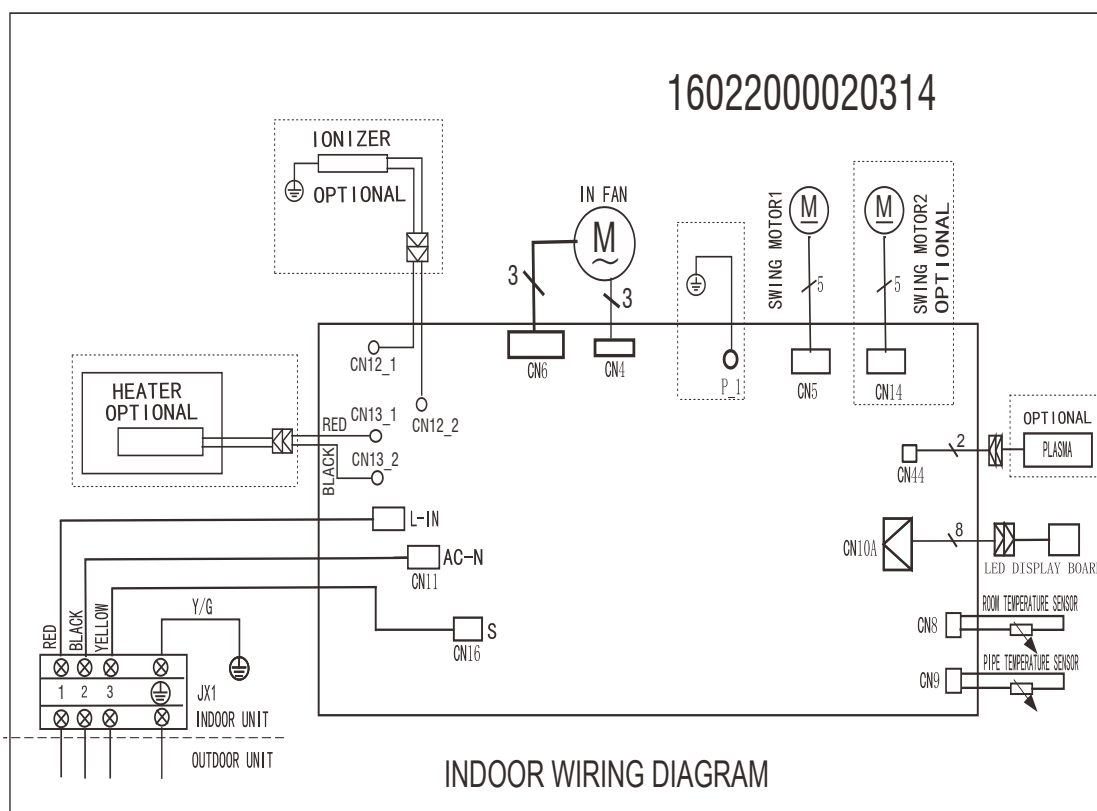

MSABA-09HRFN1-BQ0W,MSABB-12HRFN1-BQ0W,MSABA-09HRFN1-MQ0W,MSABB-12HRFN1-MQ0W,
 MSABD-18HRFN1-MQ0W, MSABE-23HRFN1-MQ0W,MSABF-30HRFN1-MR0W, MSABF-36HRFN1-MPOW,
 MSABD-17CRFN1-MQ0W

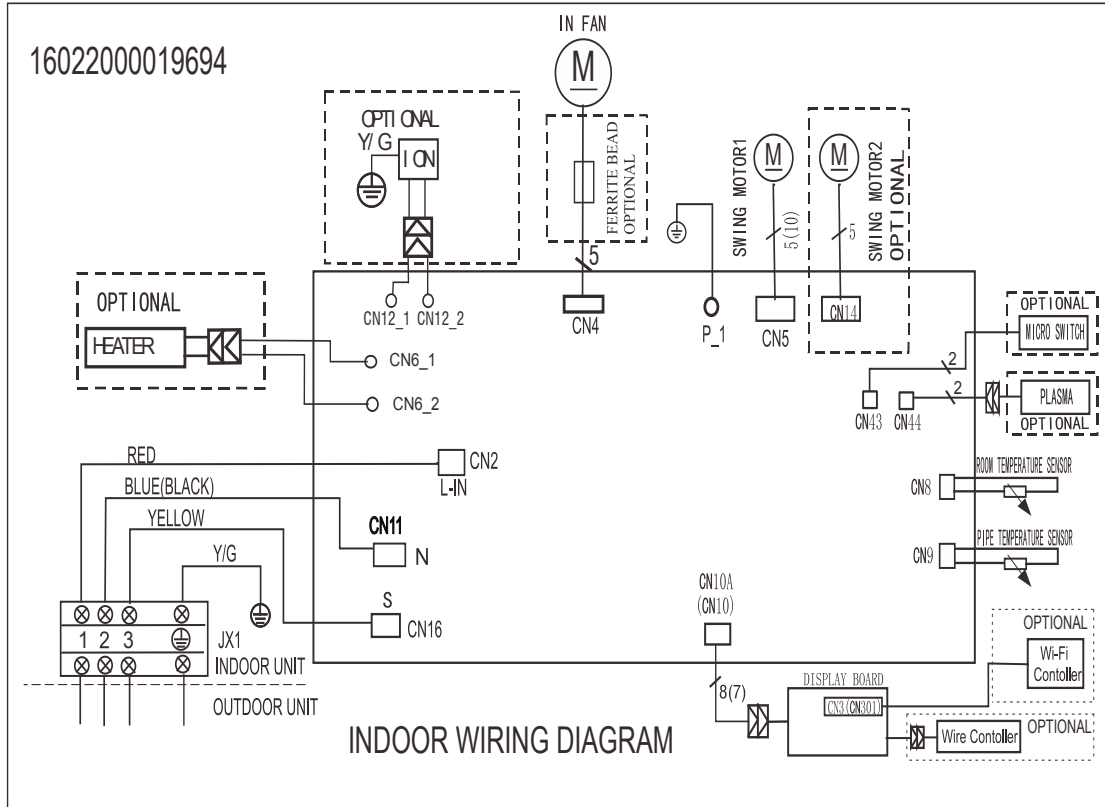

MSABE-23CRDN1-MPOW

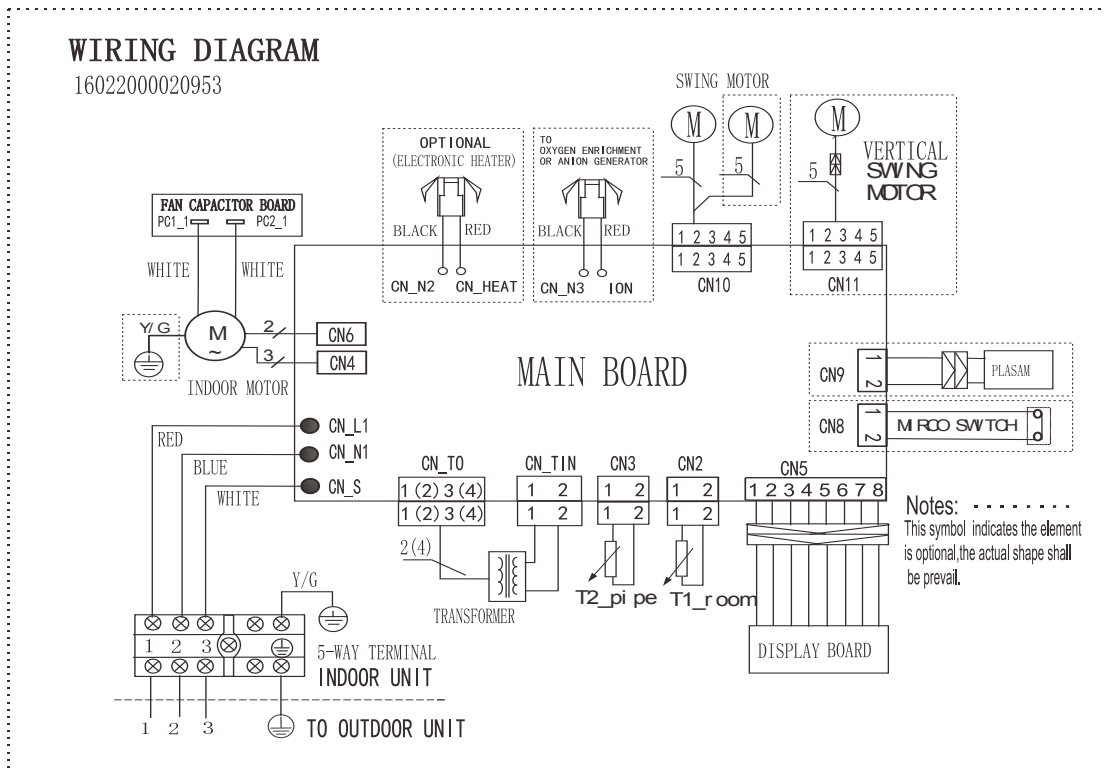

2.2 Outdoor Unit

Abbreviation	Paraphrase
4-WAY	Gas Valve Assembly/4-WAY VALVE
AC-FAN	Alternating Current FAN
DC-FAN	Direct Current FAN
CT1	AC Current Detector
COMP	Compressor
L-PRO	Low Pressure Switch
H-PRO	High Pressure Switch
T3	Coil Temperature of Condenser
T4	Outdoor Ambient Temperature
TH	Compressor Suction Temperature
TP	Compressor Discharge Temperature
EEV	Electronic expansion valve

MOBA30-09CFN1-MP0W, MOBA30-12CFN1-MP0W, MOBA30-09HDN1-MQ0W, MOBA30-12HDN1-MQ0W:

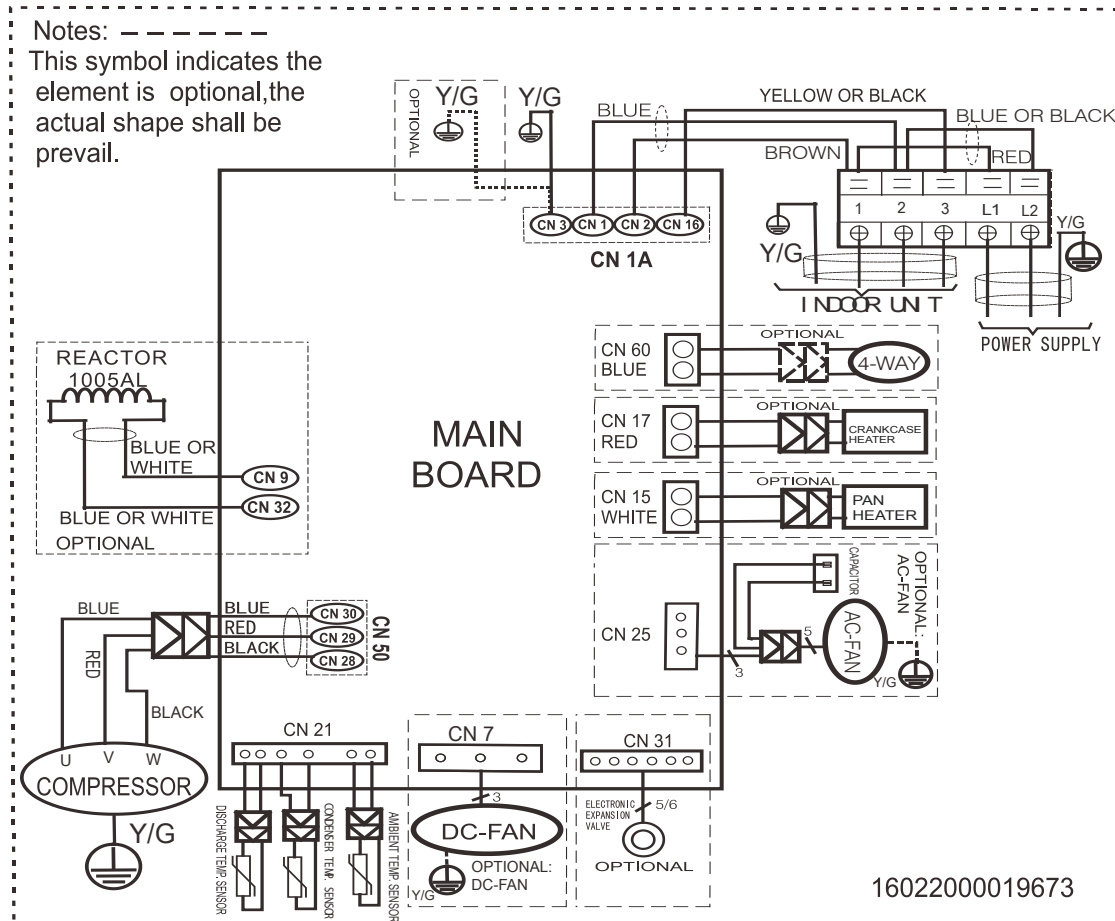

MOB30-18HDN1-MQ0W, MOCA30-23HDN1-MQ0W:

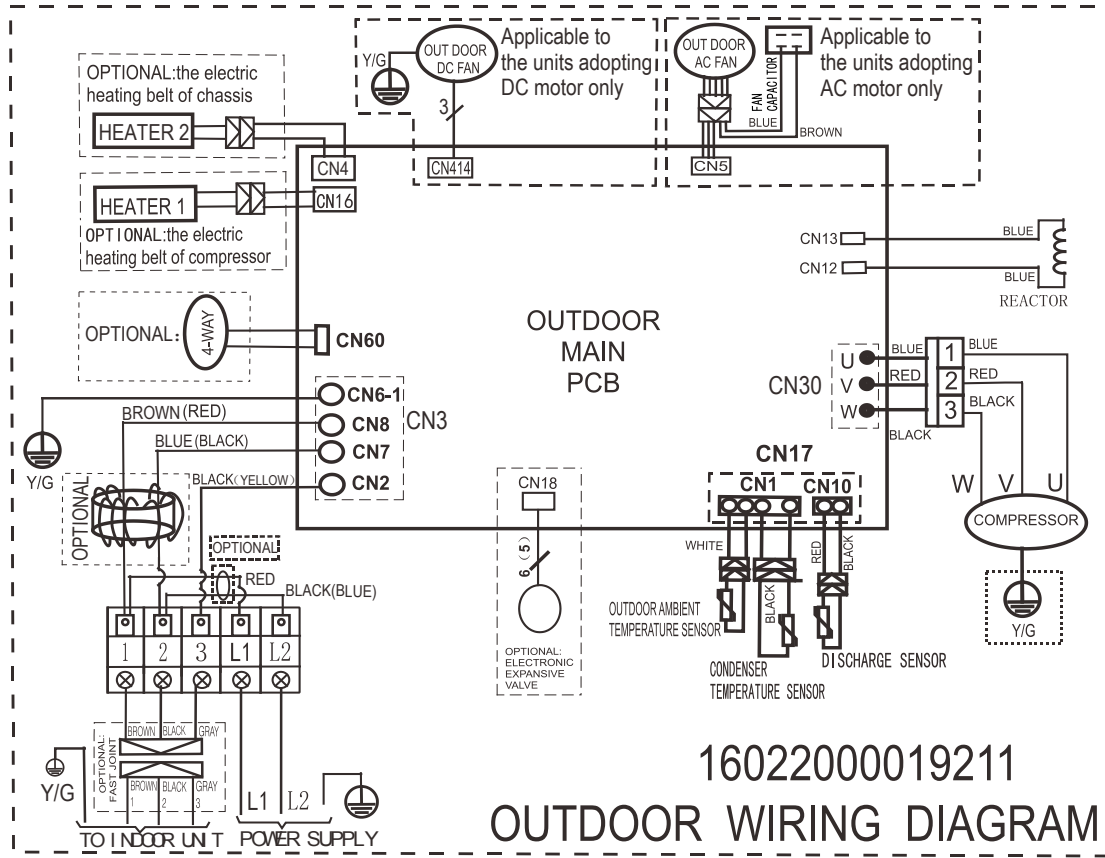

MOBA30-09CFN1-BP0W, MOBA30-12CFN1-BP0W, MOBA30-09HDN1-BQ0W, MOBA30-12HDN1-BQ0W:

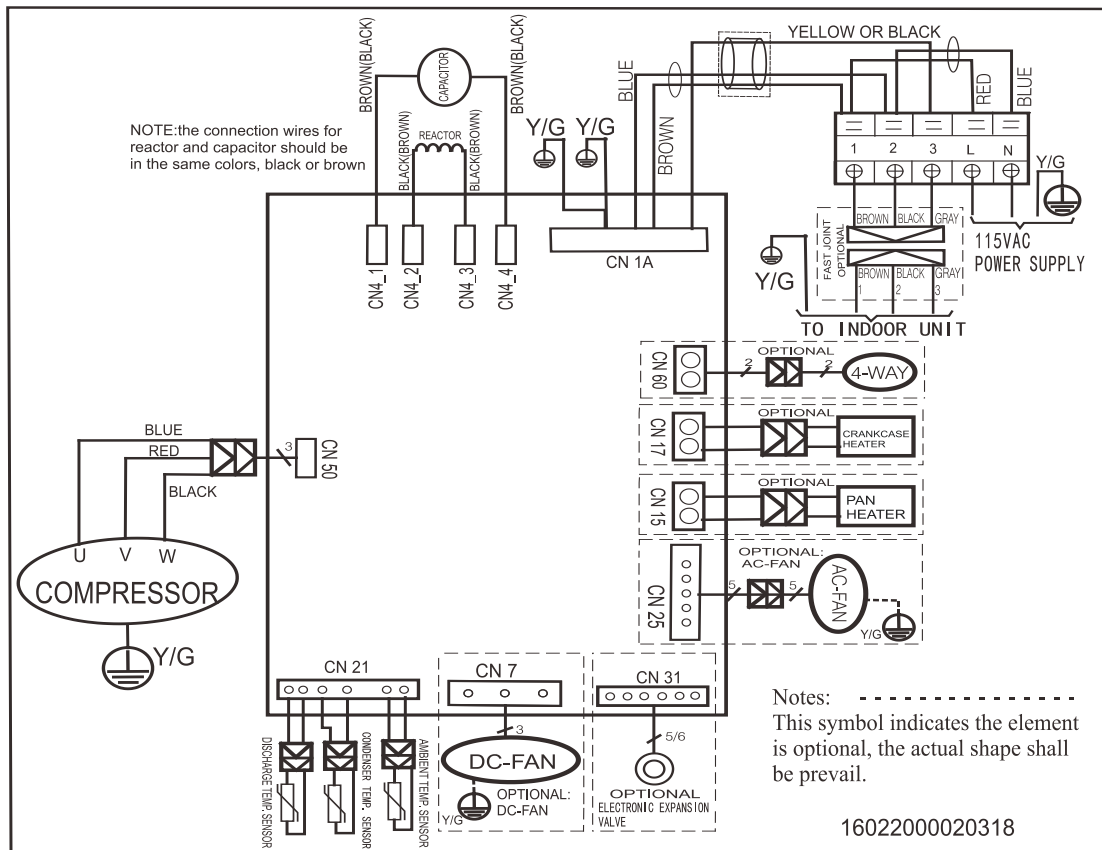

Notes:

 This symbol indicates the element is optional, the actual shape shall be prevail.

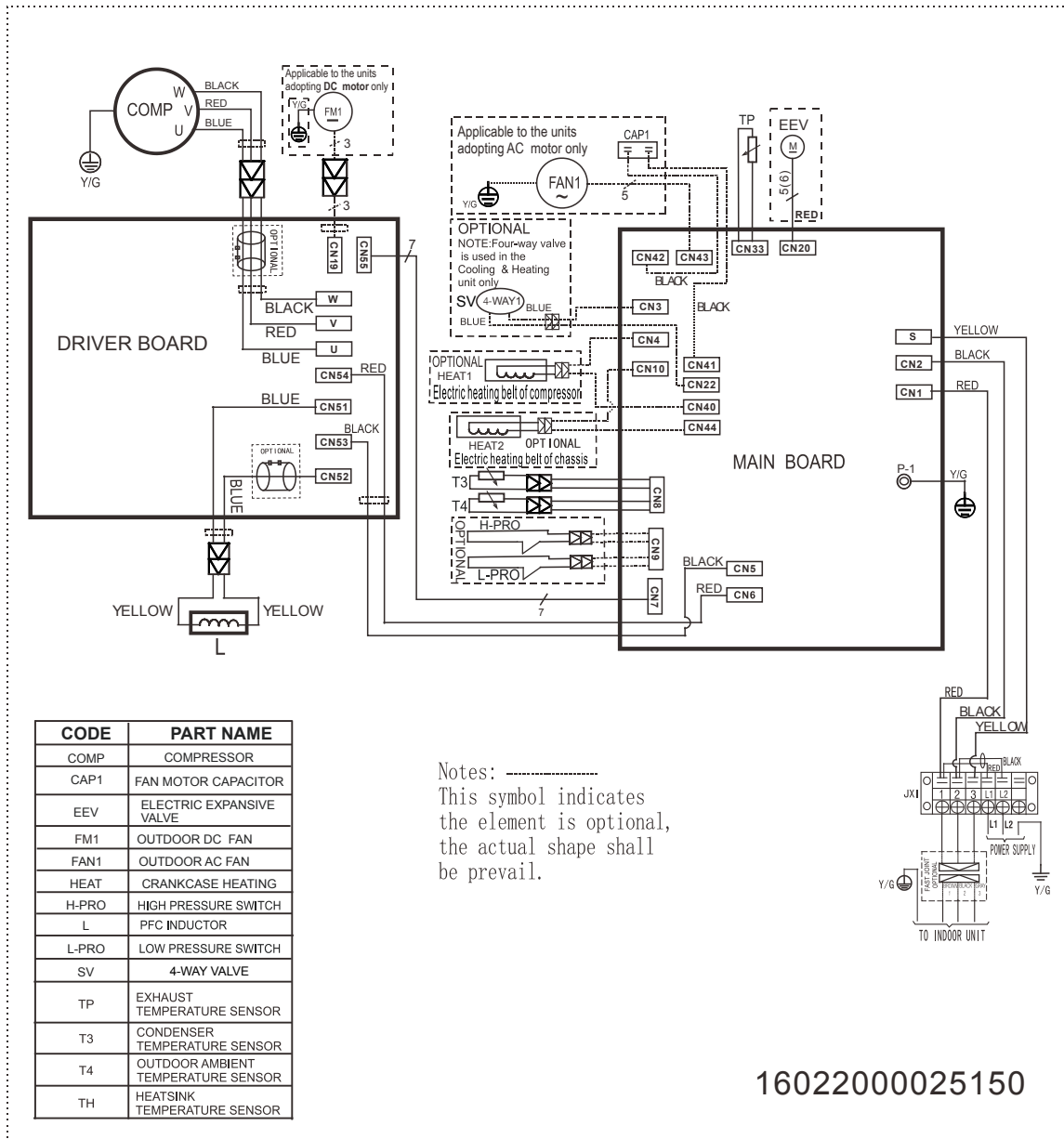

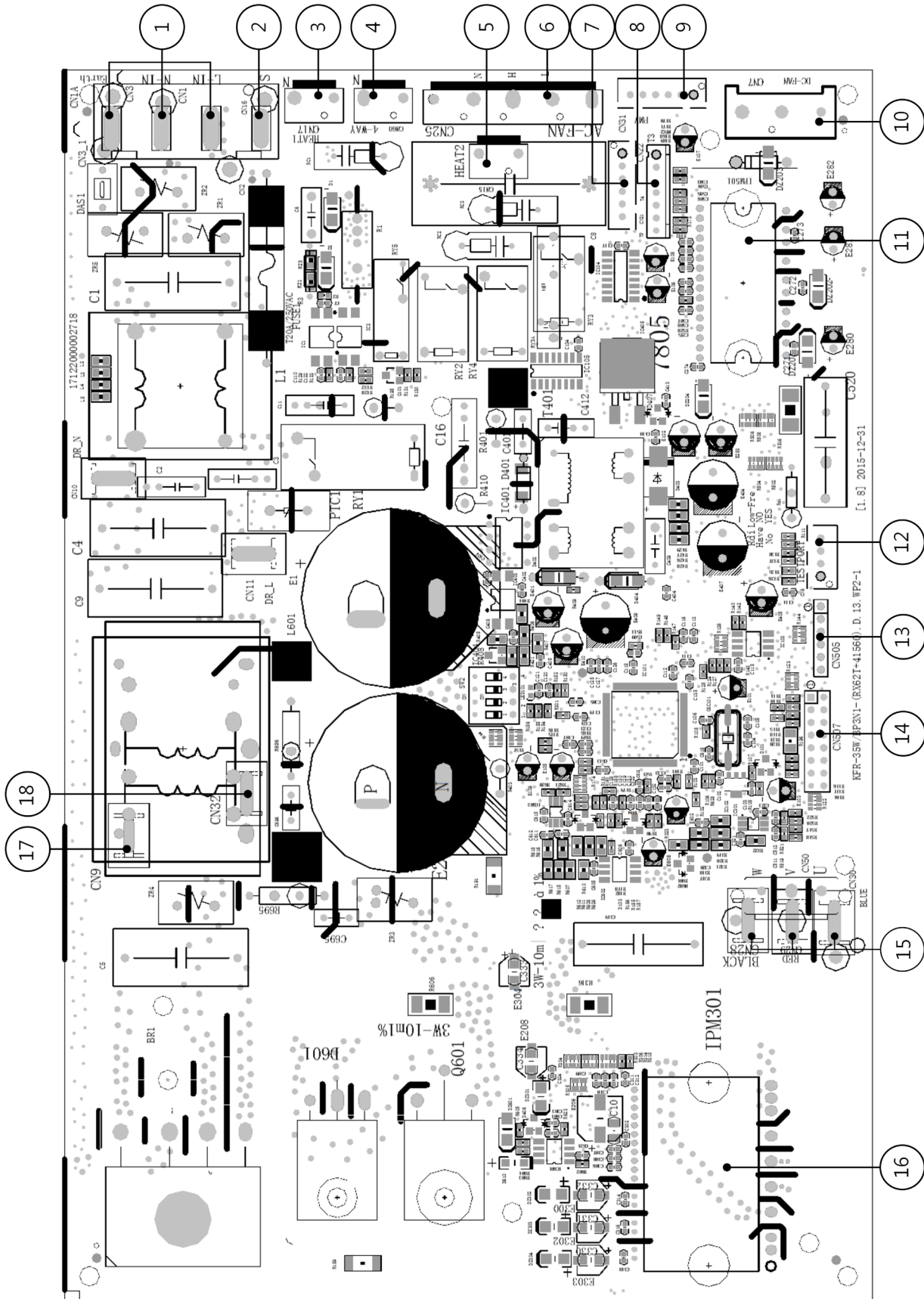

No.	Name	CN#	Meaning
1	Power Supply	CN3	Earth: connect to Ground
		CN1	N_in: connect to N-line (208-230V AC input)
		CN2	L_in: connect to L-line (208-230V AC input)
2	S	CN16	S: connect to indoor unit communication
3	HEAT1	CN17	connect to compressor heater, 208-230V AC when is ON
4	4-WAY	CN60	connect to 4 way valve, 208-230V AC when is ON.
5	HEAT2	CN15	connect to chassis heater, 208-230V AC when is ON
6	AC-FAN	CN25	connect to AC fan
7	TP T4 T3	CN22	connect to pipe temp. sensor T3, ambient temp. sensor T4, exhaust temp. sensor TP
8	TP T4 T3	CN21	connect to pipe temp. sensor T3, ambient temp. sensor T4, exhaust temp. sensor TP
9	PMV	CN31	connect to Electric Expansion Valve
10	DC-FAN	CN7	connect to DC fan
11	FAN_IPM	IPM 501	IPM for DC fan
12	TESTPORT	CN6	used for testing
13	EE_PORT	CN505	EEPROM programmer port
14	MCUPORT	CN507	connect to PC communication
15	W	CN28	connect to compressor
	V	CN29	0V AC (standby)
	U	CN30	10-200V AC (running)
16	COMP_IPM	IPM 301	IPM for compressor
17	CN9	CN9	connect to reactor
18	CN32	CN32	connect to reactor

Note: This section is for reference only. Please take practicality as standard.

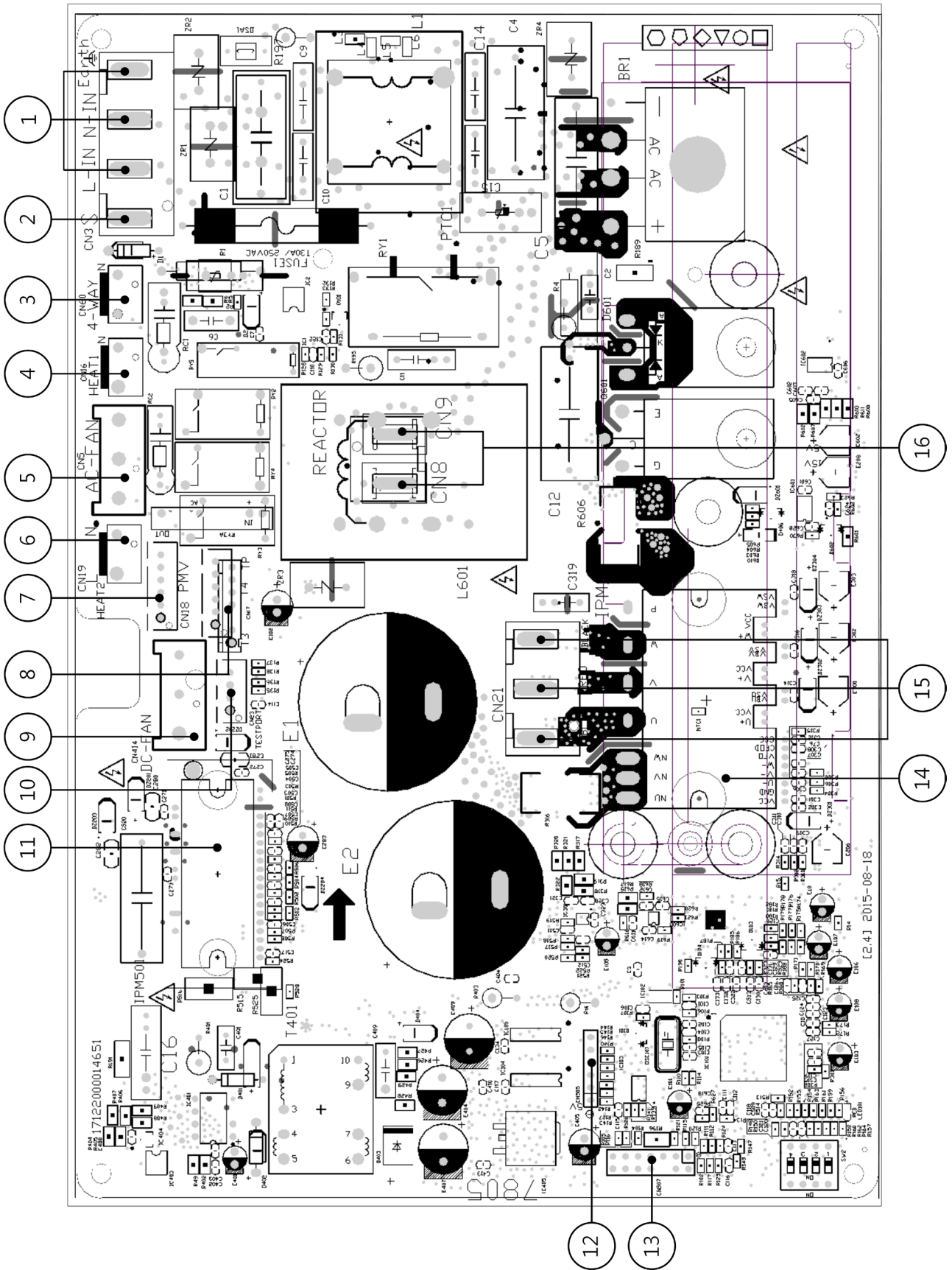

No.	Name	CN#	Meaning
1	Power Supply	Earth	Earth: connect to Ground
		N_IN	N_in: connect to N-line (208-230V AC input)
		L_IN	L_in: connect to L-line (208-230V AC input)
2	S	CN3	S: connect to indoor unit communication
3	4-WAY	CN60	connect to 4 way valve, 208-230V AC when is ON.
4	HEAT1	CN16	connect to compressor heater, 208-230V AC when is ON
5	AC-FAN	CN5	connect to AC fan
6	HEAT2	CN19	connect to chassis heater, 208-230V AC when is ON
7	PMV	CN18	connect to Electric Expansion Valve
8	TP T4 T3	CN17	connect to pipe temp. sensor T3, ambient temp. sensor T4, exhaust temp. sensor TP
9	DC-FAN	CN7	connect to DC fan
10	TESTPORT	CN23	used for testing
11	FAN_IPM	IPM 501	IPM for DC fan
12	EE_PORT	CN505	EEPROM programmer port
13	MCUPORT	CN507	connect to PC communication
14	COMP_IPM	IPM 301	IPM for compressor
15	U	CN28	connect to compressor
	V	CN29	0V AC (standby)
	W	CN30	200-300V AC (running)
16	CN8/CN9	CN8/CN9	connect to reactor

Note: This section is for reference only. Please take practicality as standard.

No.	Name	CN#	Meaning
1	Power Supply	CN3	Earth: connect to Ground
		CN1	N_in: connect to N-line (100-130V AC input)
		CN2	L_in: connect to L-line (100-130V AC input)
2	S	CN16	S: connect to indoor unit communication
3	HEAT1	CN17	connect to compressor heater, 100-130V AC when is ON
4	4-WAY	CN60	connect to 4 way valve, 100-130V AC when is ON.
5	AC-FAN	CN25	connect to AC fan
6	TP T4 T3	CN21	connect to pipe temp. sensor T3, ambient temp. sensor T4, exhaust temp. sensor TP
7	HEAT2	CN15	connect to chassis heater, 100-130V AC when is ON
8	PMV	CN31	connect to Electric Expansion Valve
9	DC-FAN	CN7	connect to DC fan
10	FAN_IPM	IPM 501	IPM for DC fan
11	TESTPORT	CN6	used for testing
12	EE_PORT	CN505	EEPROM programmer port
13	MCUPORT	CN507	connect to PC communication
14	W	CN28	connect to compressor
	V	CN29	0V AC (standby)
	U	CN30	10-230V AC (running)
15	COMP_IPM	IPM 301	IPM for compressor
16	BR1	BR1	Bridge

Note: This section is for reference only. Please take practicality as standard.

No.	Name	CN#	Meaning
1	Power Supply	CN3	Earth: connect to Ground
		CN7	N_in: connect to N-line (208-230V AC input)
		CN8	L_in: connect to L-line (208-230V AC input)
2	S	CN3	S: connect to indoor unit communication
3	4-WAY	CN60	connect to 4 way valve, 208-230V AC when is ON.
4	HEAT1	CN17	connect to compressor heater, 208-230V AC when is ON
5	AC-FAN	CN11	connect to AC fan
6	HEAT2	CN16	connect to chassis heater, 208-230V AC when is ON
7	CN38	CN38	connect to PC communication
8	PMV	CN18	connect to Electric Expansion Valve
9	DC-FAN	CN414	connect to DC fan
10	FAN_IPM	IPM 501	IPM for DC fan
11	CN19	CN19	internal drive motor
12	TESTPORT	CN23	used for testing
13	CN9	CN9	connect to PC communication
14	U	CN28	connect to compressor
	V	CN29	0V AC (standby)
	W	CN30	10-200V AC (running)
15	COMP_IPM	IPM 301	IPM for compressor

Note: This section is for reference only. Please take practicality as standard.

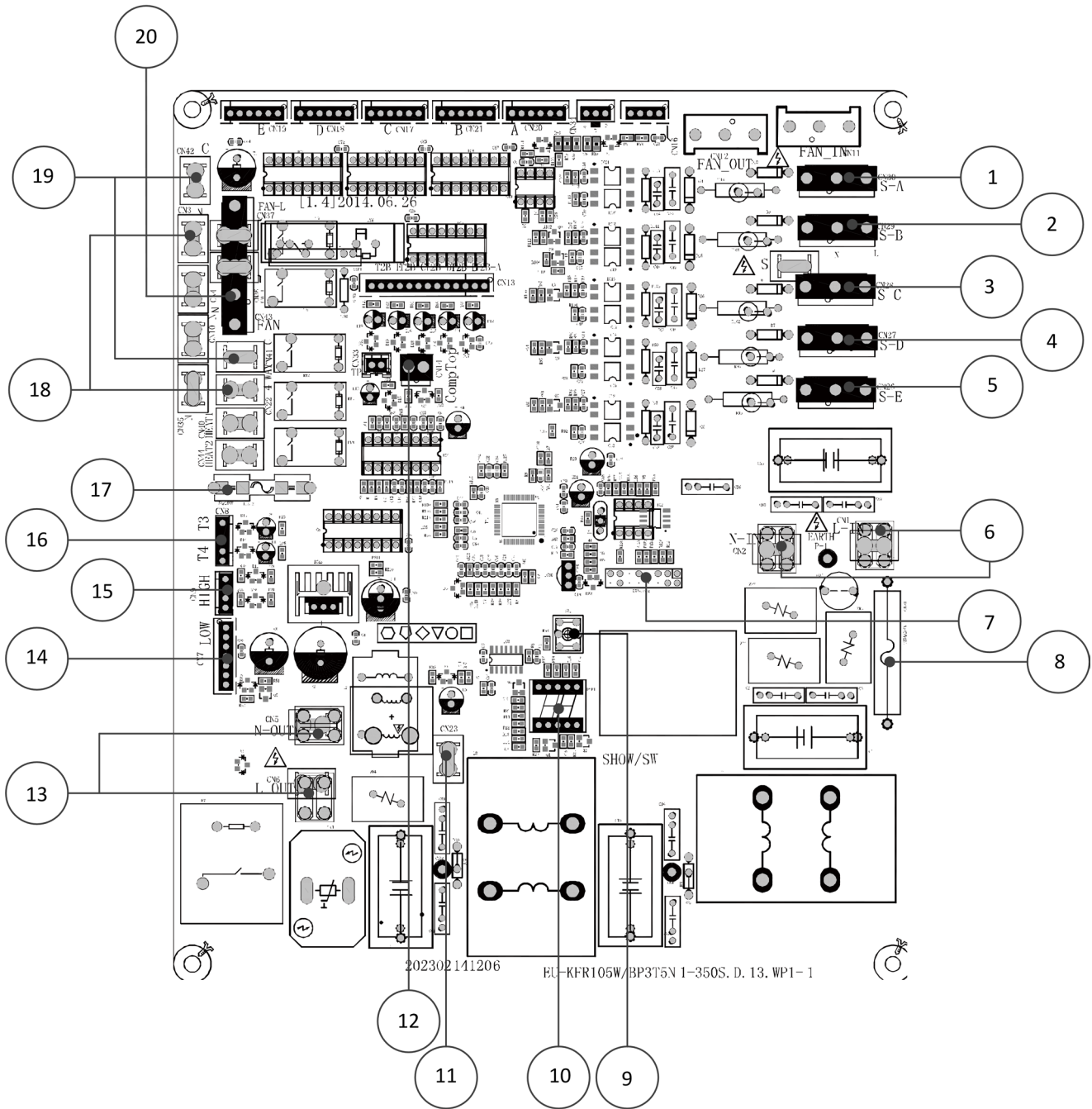

No.	Name	CN#	Meaning
1	S-A	CN30	Current loop communication A, signal wire, connect to the terminal (24V DC Pulse wave)
2	S-B	CN29	Current loop communication B, signal wire, connect to the terminal (24V DC Pulse wave)
3	S-C	CN28	Current loop communication C, signal wire, connect to the terminal (24V DC Pulse wave)
4	S-D	CN30	Current loop communication D, signal wire, connect to the terminal (24V DC Pulse wave)
5	S-E	CN30	Current loop communication E, signal wire, connect to the terminal (24V DC Pulse wave)
6	L-IN	CN1	Power supply, connect to the terminal (208-230V AC)
	N-IN	CN2	
7	Test report	CONdebug	Connect to detector
8	Fuse	Fuse 1	Fuse T30A/250V
9	SW1	SW1	Digital display button
10	DSP1	DSP1	Digital display
11	CN23	CN23	CN23 reserve
12	CN14	CN14	Connect to exhaust temperature sensor
13	N-OUT	CN5	Connect to the terminal (208-230V AC)
	L-OUT	CN6	
14	CN7	CN7	Connect to inverter driver
15	LOW / HIGH	CN9	Connect to high and low pressure sensor
16	T3 / T4	CN8	Connect to T3 / T4 temperature sensor
17	Fuse	Fuse 2	Fuse 5A/250V
18	L	CN22	Connect to the 4-way valve. When the 4-way is ON, output 208-230V AC.
	N	CN3	
19	CN42	CN42	Connect to motor capacitor
	CN41	CN41	
20	AC Fan	CN43	Connect to AC fan motor

Note: This section is for reference only. Please take practicality as standard.

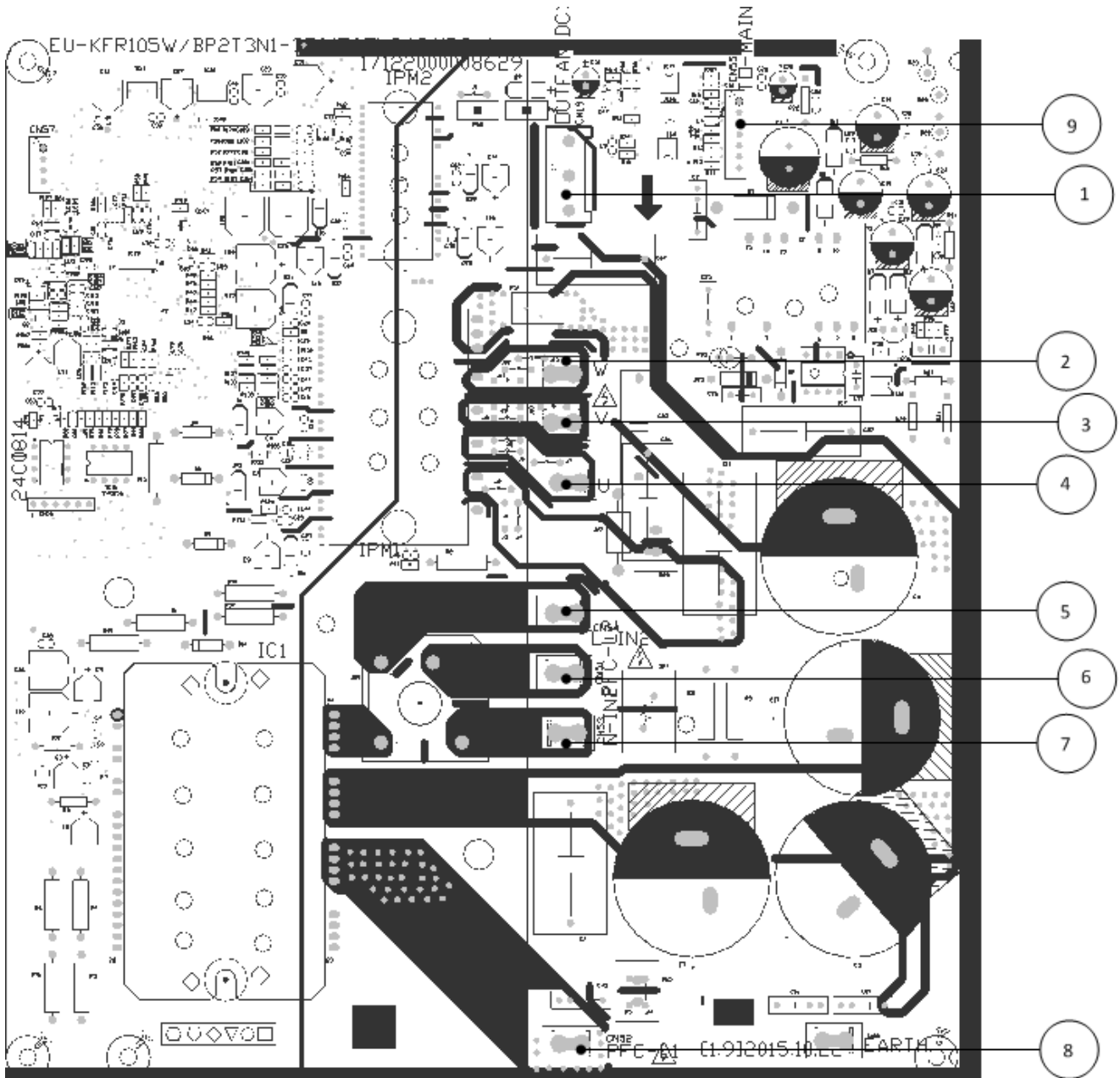

No.	Name	CN#	Meaning
1	OUT FAN (DC)	CN19	Connect to DC motor
2	W	J13	Connect to compressor W
3	V	J10	Connect to compressor V
4	U	J7	Connect to compressor U
5	CN54	CN54	Connect to main PCB CN6
6	CN51	CN51	Connect to PFC inductor
7	CN53	CN53	Connect to main PCB CN5
8	CN52	CN52	Connect to PFC inductor
9	CN55	CN55	Connect to main PCB CN7

Note: This section is for reference only. Please take practicality as standard.

Product Features

Contents

1.	Operation Modes and Functions	24
1.1	Abbreviation.....	24
1.2	Safety Features	24
1.3	Display Function	25
1.4	Fan Mode.....	25
1.5	Cooling Mode	25
1.6	Heating Mode	25
1.7	Auto-mode.....	26
1.8	Drying Mode	26
1.9	Forced Operation Function	26
1.10	Timer function.....	26
1.11	Sleep function	27
1.12	Auto-Restart Function.....	27
1.13	Refrigerant Leakage Detection.....	27
1.14	Louver Position Memory Function	27
1.15	8°C Heating(Optional)	27
1.16	Self Clean(Optional).....	27
1.17	Follow Me(Optional)	27
1.18	Silence (Optional).....	27
1.19	Information Inquiry.....	28

1. Operation Modes and Functions

1.1 Abbreviation

Unit element abbreviations

Abbreviation	Element
T1	Indoor room temperature
T2	Coil temperature of evaporator
T3	Coil temperature of condenser
T4	Outdoor ambient temperature
TS	Set temperature
TP	Compressor discharge temperature

1.2 Safety Features

Compressor three-minute delay at restart

Compressor functions are delayed for up to one minute upon the first startup of the unit, and are delayed for up to three minutes upon subsequent unit restarts.

Temperature protection of compressor top

The unit will stop working when the compressor top temp. protector cut off, and will restart after the compressor top temp. protector restart.

Automatic shutoff based on discharge temperature

If the compressor discharge temperature exceeds 115°C for five seconds, the compressor ceases operation.

Automatic shutoff based on fan speed

If the indoor fan speed registers below 300RPM for an extended period of time, the unit ceases operation and the corresponding error code is displayed on the indoor unit.

Inverter module protection

The inverter module has an automatic shutoff mechanism based on the unit's current, voltage, and temperature. If automatic shutoff is initiated, the corresponding error code is displayed on the indoor unit and the unit ceases operation.

Indoor fan delayed operation

- When the unit starts, the louver is automatically activated and the indoor fan will operate after a period of 7 seconds.
- If the unit is in heating mode, the indoor fan is regulated by the anti-cold wind function.

Compressor preheating

Preheating is automatically activated when T4 sensor is

lower than 3°C.

Sensor redundancy and automatic shutoff

- If one temperature sensor malfunctions, the air conditioner continues operation and displays the corresponding error code, allowing for emergency use.
- When more than one temperature sensor is malfunctioning, the air conditioner ceases operation.

Refrigerant leakage detection

This function is active only when cooling mode is selected. It will detect if the compressor is being damaged by refrigerant leakage or by compressor overload. This is measured using the coil temperature of evaporator T2 when the compressor is in operation.

Zero crossing detection error protection

If AC detects time interval is not correct for continuous 240s, the unit will stop and the LED will display the failure. The correct zero crossing signal time interval should be between 6-13ms.

1.3 Display Function

Unit display functions



Function	Display
Temperature	Set temperature value
Temperature (fan and Drying mode)	Room temperature
Activation of Timer ON, Fresh, Swing, Turbo, or Silent	00 (3s)
Cancellation of Timer OFF, Fresh, Swing, Turbo, or Silent	0F (3s)
Defrost	df
Warming in heating mode	cf
Self-clean (available on select units only)	sc
Heating in room temperature under 8°C	FP
ECO function (available on select units only)	E → C → 0 → set temperature gradually illuminates to 88 in one second interval

1.4 Fan Mode

When fan mode is activated:

- The outdoor fan and compressor are stopped.
- Temperature control is disabled and no temperature setting is displayed.
- The indoor fan speed can be set to high, med, low, or auto.
- The louver operations are identical to those in cooling mode.
- Auto fan: In fan-only mode, AC operates the same as auto fan in cooling mode with the temperature set at 24°C.

1.5 Cooling Mode

1.5.1 Compressor Control

ΔT is the programmed parameter of temperature compensation.

- When $T1-Ts < \Delta T-2^\circ C$, the compressor ceases operation.
- When $T1-Ts > \Delta T+3^\circ C$, the compressor continues operation.
- When the AC is operating in mute mode, the compressor operates at a low frequency.
- When the current exceeds the preset value, the current protection function activates and the compressor ceases operation.

1.5.2 Indoor Fan Control

- In cooling mode, the indoor fan operates continuously. The fan speed can be set to high, medium, low, or auto.
- If the compressor ceases operations when the configured temperature is reached, the indoor fan motor operates at the minimum or configured speed.

1.5.3 Outdoor Fan Control

- The outdoor unit will be run at different fan speed according to T4.
- For different outdoor units, the fan speeds are different.

1.5.4 Condenser Temperature Protection

When condenser temperature is more than setting value, the compressor will stop.

1.5.5 Evaporator Temperature Protection

When evaporator temperature drops below a configured value, the compressor and outdoor fan ceases operations.

1.6 Heating Mode

1.6.1 Compressor Control

ΔT is the programmed parameter of temperature compensation.

- When $T1-Ts > -\Delta T$, the compressor ceases operation.
- When $T1-Ts < -\Delta T-1.5^\circ C$, the compressor continues operation.
- When the AC is operating in mute mode, the compressor operates at a low frequency.
- When the current exceeds the preset value, the current protection function activates and the compressor ceases operation.

1.6.2 Indoor Fan Control:

- When the compressor is on, the indoor fan can be set to high/med/low/auto.
- When indoor unit coil temperature is low, the anti-cold air function will start and indoor fan motor will run at low speed, the speed can't be changed ,when the temperature is lower than setting value, the indoor fan motor will stop.
- When the indoor temperature reaches the setting temperature, the compressor will stop, the indoor fan motor will run at the minimum speed or setting speed.(The anti-cold air function is valid).

1.6.3 Outdoor Fan Control:

- The outdoor unit will be run at different fan speed according to T4.
- For different outdoor units, the fan speeds are different.

1.6.4 Defrosting mode

- The unit enters defrosting mode according to changes in the temperature value of T3 as well as the compressor running time.
- In defrosting mode, the compressor continues to run, the indoor and outdoor motor will cease operation, the defrost light of the indoor unit will turn on, and the "df" symbol is displayed.
- If any one of the following conditions is satisfied, defrosting ends and the machine switches to normal heating mode:
 - T3 rises above TCDE1°C.
 - T3 maintained above TCDE2°C for 80 seconds.
 - Unit runs for 15 minutes consecutively in defrosting mode.

1.6.5 Evaporator Temperature Protection

When the evaporator temperature exceeds a preset protection value, the compressor stops.

1.7 Auto-mode

- This mode can be selected with the remote controller and the setting temperature can be changed between 17°C~30°C.
- In auto mode, the machine selects cooling, heating, or fan-only mode on the basis of ΔT ($\Delta T = T1 - T_s$).

ΔT	Running mode
$\Delta T > 2^\circ\text{C}$	Cooling
$-2^\circ\text{C} \leq \Delta T \leq 2^\circ\text{C}$	Fan-only
$\Delta T < -2^\circ\text{C}$	Heating*

Heating*: In auto mode, cooling only models run the fan

- The louver operates same as in relevant mode.
- If the machine switches mode between heating and cooling, the compressor will keep stopping for certain time and then choose mode according to T1-Ts.
- If the setting temperature is modified, the machine will choose running function again.

1.8 Drying mode

- Indoor fan speed is fixed at breeze and can't be changed. The louver angle is the same as in cooling mode.
- All protections are active and the same as that in cooling mode.

1.9 Forced operation function

- Forced cooling mode:

The compressor and outdoor fan continue to run and the indoor fan runs at low speed. After running for 30 minutes, the AC will switch to auto mode with a preset temperature of 24°C.

- Forced auto mode:

Forced auto mode operates the same as normal auto mode with a preset temperature of 24°C.

- The unit exits forced operation when it receives the following signals:
 - Switch on
 - Switch off
 - Timer on
 - Timer off
 - Changes in:
 - mode
 - fan speed
 - sleeping mode
 - Follow me

1.10 Timer function

- Timing range is 24 hours.
- Timer on. The machine will turn on automatically when reaching the setting time.
- Timer off. The machine will turn off automatically when reaching the setting time.
- Timer on/off. The machine will turn on automatically when reaching the setting "on" time, and then turn off automatically when reaching the setting "off" time.

- Timer off/on. The machine will turn off automatically when reaching the setting “off” time, and then turn on automatically when reaching the setting “on” time.
- The timer function will not change the AC current operation mode. Suppose AC is off now, it will not start up firstly after setting the “timer off” function. And when reaching the setting time, the timer LED will be off and the AC running mode has not been changed.
 - The setting time is relative time.
 - The AC will quit the timer function when it has malfunction

1.11 Sleep function

- The sleep function is available in cooling, heating or auto mode.
- Operation process in sleep mode is as follow:
- When cooling, the setting temperature rises 1 °C (be lower than 30 °C) every one hour, 2 hours later the setting temperature stops rising and the indoor fan is fixed at low speed.
- When heating, the setting temperature decreases 1 °C (be higher than 17 °C) every one hour, 2 hours later the setting temperature stops rising and indoor fan is fixed at low speed. (Anti-cold wind function has the priority).
- Operation time in sleep mode is 7 hours. After 7 hours the AC quits this mode and turns off.
- Timer setting is available.

1.12 Auto-Restart function

- The indoor unit has an auto-restart module that allows the unit to restart automatically. The module automatically stores the current settings (not including the swing setting) and, in the case of a sudden power failure, will restore those setting automatically within 3 minutes after power returns.
- If the unit was in forced cooling mode, it will run in this mode for 30 minutes and turn to auto mode with temperature set to 24°C.
- If there is a power failure while the unit is running, the compressor starts 3 minutes after the unit restarts. If the unit was already off before the power failure, the compressor starts 1 minute after the unit restarts.

1.13 Refrigerant Leakage Detection

With this new technology, the display area will show “EC” when the outdoor unit detects refrigerant leakage.

1.14 Louver Position Memory Function

When starting the unit again after shutting down, its louver will restore to the angle originally set by the user, but the precondition is that the angle must be within the allowable range, if it exceeds, it will memorize the maximum angle of the louver. During operation, if the power fails or the end user shuts down the unit in the turbo mode, the louver will restore to the default angle.

1.15 8°C Heating(Optional)

In heating mode, the temperature can be set to as low as 8°C, preventing the indoor area from freezing if unoccupied during severe cold weather.

1.16 Self clean(Optional)

- If you press “Self Clean” when the unit is in cooling or drying mode:
 - For cooling models, the indoor unit will run in low fan mode for a certain time, then ceases operation.
 - For heat pump models, the indoor unit will run in fan-only mode, then low heat, and finally in fan-only mode.
- Self Clean keeps the indoor unit dry and prevents mold growth.

1.17 Follow me(Optional)

- If you press “Follow Me” on the remote, the indoor unit will beep. This indicates the follow me function is active.
- Once active, the remote control will send a signal every 3 minutes, with no beeps. The unit automatically sets the temperature according to the measurements from the remote control.
- The unit will only change modes if the information from the remote control makes it necessary, not from the unit’s temperature setting.
- If the unit does not receive a signal for 7 minutes or you press “Follow Me,” the function turns off. The unit regulates temperature based on its own sensor and settings.

1.18 Silence (Optional)

Press “Silence” on the remote control to enable the SILENCE function. While this function is active, the compressor frequency is maintained at a lower level than F2. The indoor unit will run at faint breeze, which reduces noise to the lowest possible level.

1.19 Information Inquiry

- To enter information inquiry status, complete the following procedure within ten seconds:
 - Press LED 3 times.
 - Press SWING 3 times.
- If you are successful, you will hear beeps for two seconds.
- Use the LED and SWING buttons to cycle through information displayed.
- Pressing LED will display the next code in the sequence. Pressing SWING will show the previous.
- The table next shows information codes. The screen will display this code for two seconds, then the information for 25 seconds.

Displayed code	Explanation	Displayed value	Meaning	Additional Notes
T1	Room temperature	-1F,-1E,-1d,-1c,-1b,-1A -19—99 A0,A1,...A9 b0,b1,...b9 c0,c1,...c9 d0,d1,...d9 E0,E1,...E9 F0,F1,...F9	-25,-24,-23,-22,-21,-20 -19—99 100,101,...109 110,111,...119 120,121,...129 130,131,...139 140,141,...149 150,151,...159	<ol style="list-style-type: none"> All displayed temperatures use actual values. All temperatures are displayed in °C regardless of remote used. T1, T2, T3, T4, and T2B display ranges from -25 to 70 °C. TP display ranges from -20 to 130 °C. The frequency display ranges from 0 to 159HZ. If the actual values exceed or fall short of the defined range, the values closest to the maximum and minimum values will be displayed.
T2	Indoor coil temperature			
T3	Outdoor coil temperature			
T4	Ambient temperature			
TB	Outlet temperature of indoor coil			
TP	Discharge temperature			
TH	Suction temperature			
FT	Targeted frequency			
FR	Actual frequency			
IF	Indoor fan speed	0 1,2,3,4	OFF Low speed, Medium speed, High speed, Turbo.	N/A Used for some large capacity motors.
OF	Outdoor fan speed	14-FF	Actual fan speed is equal to the display value converted to decimal value and multiplied by 10. This is measured in RPM.	Used for some small capacity motors. The display value is 14-FF (hexadecimal). The corresponding fan speed ranges from 200 to 2550RPM.
LR	EXV opening angle	0-FF	Actual EXV opening value is equal to the display value converted to decimal value and then multiplied by 2.	-
CT	Compressor continuous running time	0-FF	0-255 minutes	If the actual value exceeds or falls short of the defined range, the value closest to the maximum and minimum will be displayed.
ST	Causes of compressor stop	0-99	For a detailed explanation, contact technical support.	-

Displayed code	Explanation	Displayed value	Meaning	Additional Notes
R0	Reserved	0-FF 2-28 5-20 5-25	-	-
R1				
b0				
b1				
b2				
b3				
b4				
b5				
b6				
dL				
Rc				
Uo				
Td				
dR				
dS				
dT				

Maintenance and Disassembly

Contents

1. Maintenance	32
1.1 First Time Installation Check	32
1.2 Refrigerant Recharge	32
1.3 Re-Installation	35
1.3.1 Indoor Unit	35
1.3.2 Outdoor Unit	35
2. Disassembly	39
2.1 Indoor Unit.....	39
2.2 Outdoor Unit.....	55

1. Maintenance

1.1 First Time Installation Check

Air and moisture trapped in the refrigerant system affects the performance of the air conditioner by:

- Increasing pressure in the system.
- Increasing the operating current.
- Decreasing the cooling or heating efficiency.
- Congesting the capillary tubing due to ice build-up in the refrigerant circuit.
- Corroding the refrigerant system.

To prevent air and moisture from affecting the air conditioner's performance, the indoor unit, as well as the pipes between the indoor and outdoor unit, must be leak tested and evacuated.

Leak test (soap water method)

Use a soft brush to apply soapy water or a neutral liquid detergent onto the indoor unit connections and outdoor unit connections. If there is gas leakage, bubbles will form on the connection.

Air purging with vacuum pump

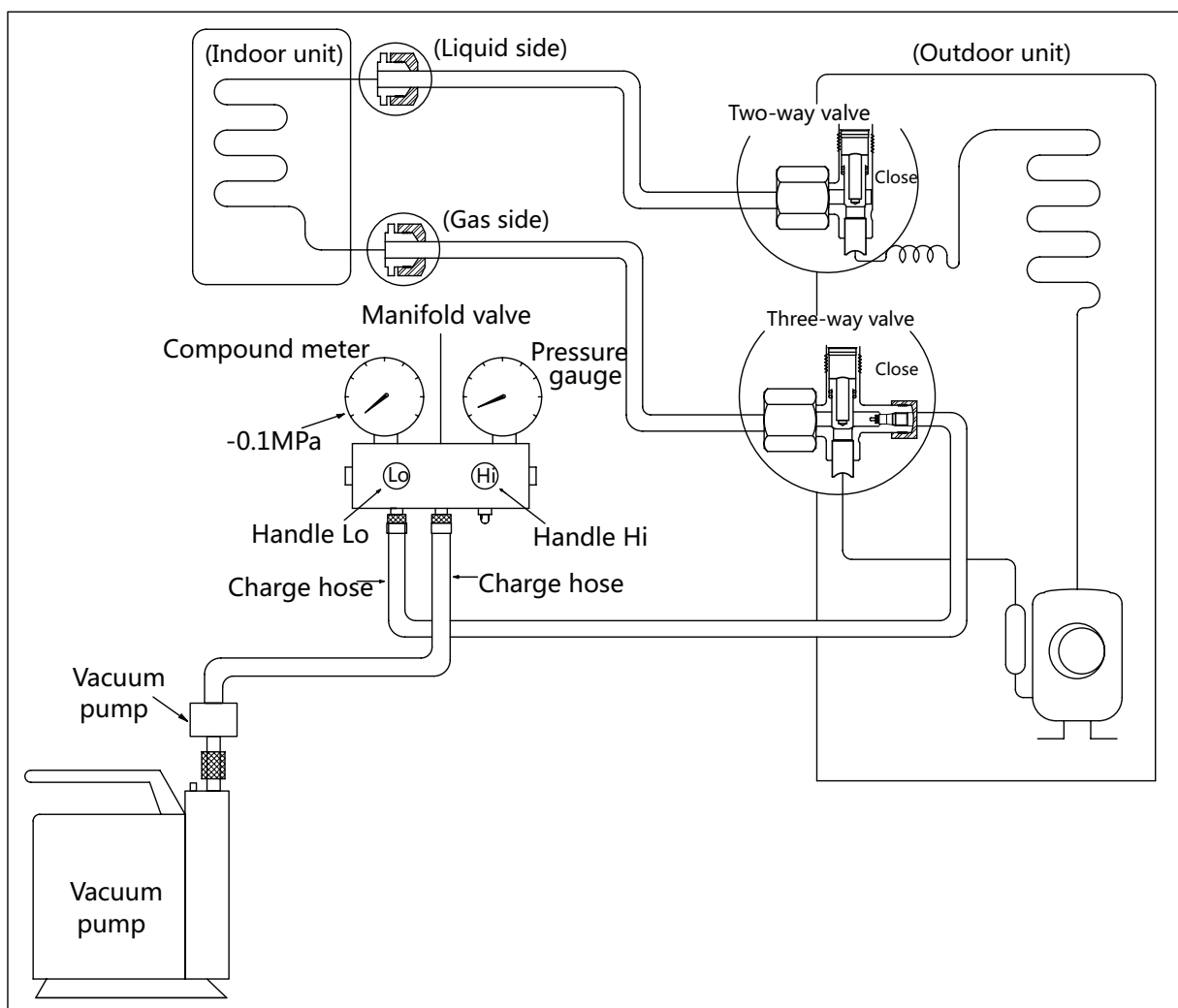

Procedure:

1. Tighten the flare nuts of the indoor and outdoor units, and confirm that both the 2- and 3-way valves are closed.
2. Connect the charge hose with the push pin of Handle Lo to the gas service port of the 3-way valve.
3. Connect the charge hose of Handle Hi connection to the vacuum pump.
4. Fully open the Handle Lo manifold valve.
5. Using the vacuum pump, evacuate the system for 30 minutes.
 - a. Check whether the compound meter indicates -0.1 MPa (14.5 Psi).
 - If the meter does not indicate -0.1 MPa (14.5 Psi) after 30 minutes, continue evacuating for an additional 20 minutes.
 - If the pressure does not achieve -0.1 MPa (14.5 Psi) after 50 minutes, check for leakage.
 - If the pressure successfully reaches -0.1 MPa (14.5 Psi), fully close the Handle Lo valve and cease vacuum pump operations.
 - b. Wait for 5 minutes then check whether the gauge needle moves after turning off the vacuum pump.
6. Loosen the flare nut of the 3-way valve for 6 or 7 seconds and then tighten the flare nut again.
 - a. Confirm the pressure display in the pressure indicator is slightly higher than the atmospheric pressure.
 - b. Remove the charge hose from the 3-way valve.
7. Fully open the 2- and 3-way valves and tighten the cap of the 3-way valve.

1.2 Refrigerant Recharge

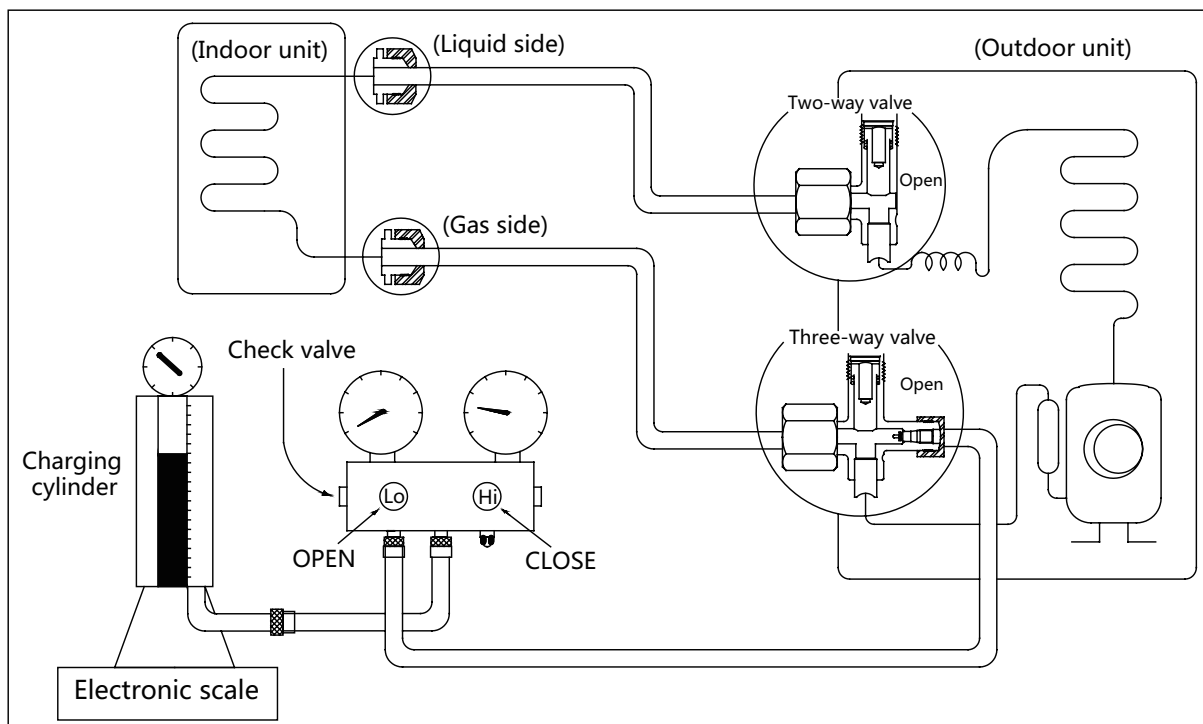

Prior to recharging the refrigerant, confirm the additional amount of refrigerant required using the following table:

Models	Standard length	Max. elevation	Max. length	Additional refrigerant
9k&12k	7.5m (24.6ft)	10m (32.8ft)	25m (82ft)	15g/m (0.16oz/ft)
17k&18k	7.5m (24.6ft)	20m (65.6ft)	30m (98.4ft)	15g/m (0.16oz/ft)
22k	7.5m (24.6ft)	20m (65.6ft)	30m (98.4ft)	30g/m (0.32oz/ft)
24k&30k	7.5m (24.6ft)	25m (82ft)	50m (164ft)	30g/m (0.32oz/ft)
36k	7.5m (24.6ft)	30m(98.4ft)	65m(213.2ft)	30g/m (0.32oz/ft)

Procedure:

1. Close both 2- and 3-way valves.
2. Slightly connect the Handle Lo charge hose to the 3-way service port.
3. Connect the charge hose to the valve at the bottom of the cylinder.
4. If the refrigerant is R410A, invert the cylinder to ensure a complete liquid charge.
5. Open the valve at the bottom of the cylinder for 5 seconds to purge the air in the charge hose, then fully tighten the charge hose with push pin Handle Lo to the service port of 3-way valve..
6. Place the charging cylinder onto an electronic scale and record the starting weight.
7. Fully open the Handle Lo manifold valve, 2- and 3-way valves.
8. Operate the air conditioner in cooling mode to charge the system with liquid refrigerant.
9. When the electronic scale displays the correct weight (refer to the gauge and the pressure of the low side to confirm), turn off the air conditioner, then disconnect the charge hose from the 3-way service port immediately..
10. Mount the caps of service port and 2- and 3-way valves.
11. Use a torque wrench to tighten the caps to a torque of 18 N.m.
12. Check for gas leakage.

1.3 Re-Installation

1.3.1 Indoor Unit

Collecting the refrigerant into the outdoor unit

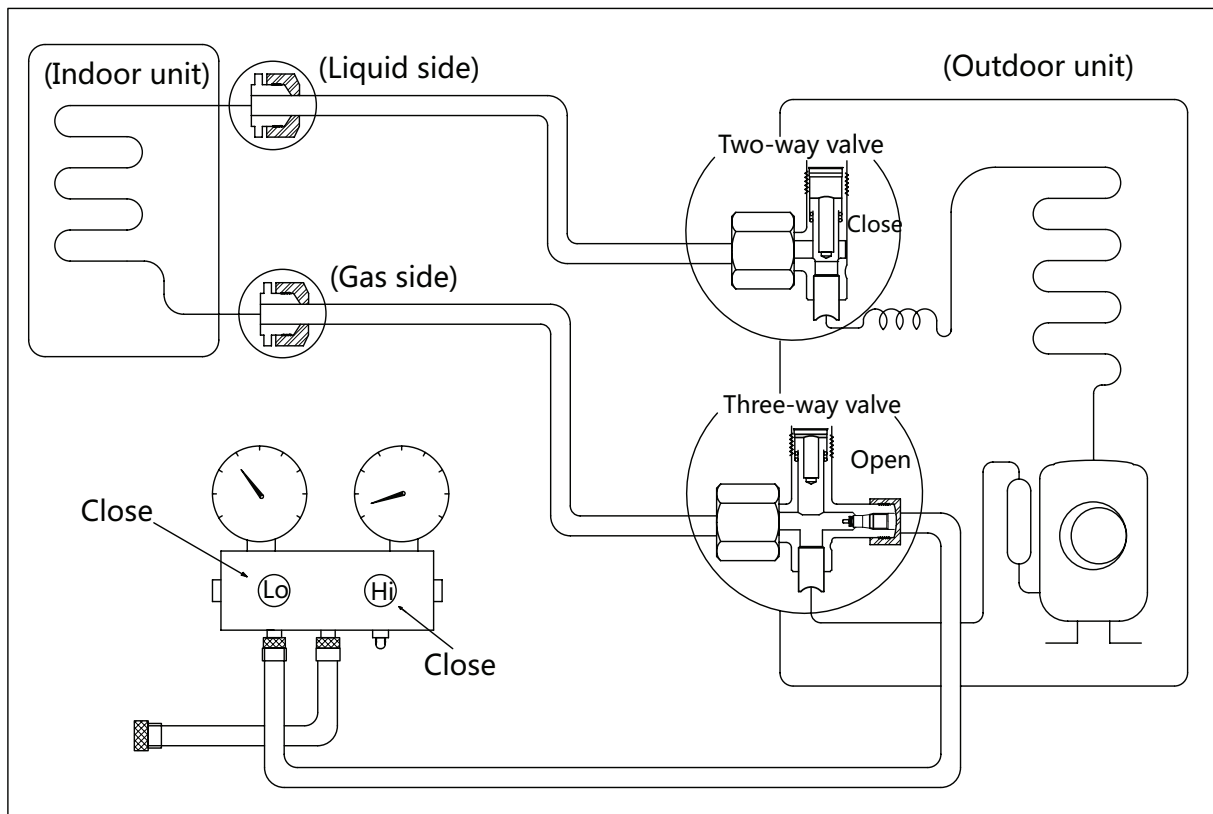

Procedure:

1. Confirm that the 2- and 3-way valves are opened.
2. Remove the valve stem caps and ensure that the valve stems are opened (use as hexagonal wrench to open the valve stems).
3. Connect the charge hose with the push pin of Handle Lo to the 3-way valve's gas service port.
4. Open the Handle Lo valve of the manifold valve to purge air from the charge hose for 5 seconds and then close it quickly.
5. Close the 2-way valve.
6. Operate the air conditioner in cooling mode. Cease operations when the gauge reaches 0.1 MPa (14.5 Psi).
7. Close the 3-way valve so that the gauge rests between 0.3 MPa (43.5 Psi) and 0.5 MPa (72.5 Psi).
8. Disconnect the charge set, and tighten the 2- and 3-way valve's stem nuts (use a torque wrench to tighten the 3-way valves service port cap to a torque of 18 N.m).
9. Check for gas leakage.

Air purging with vacuum pump

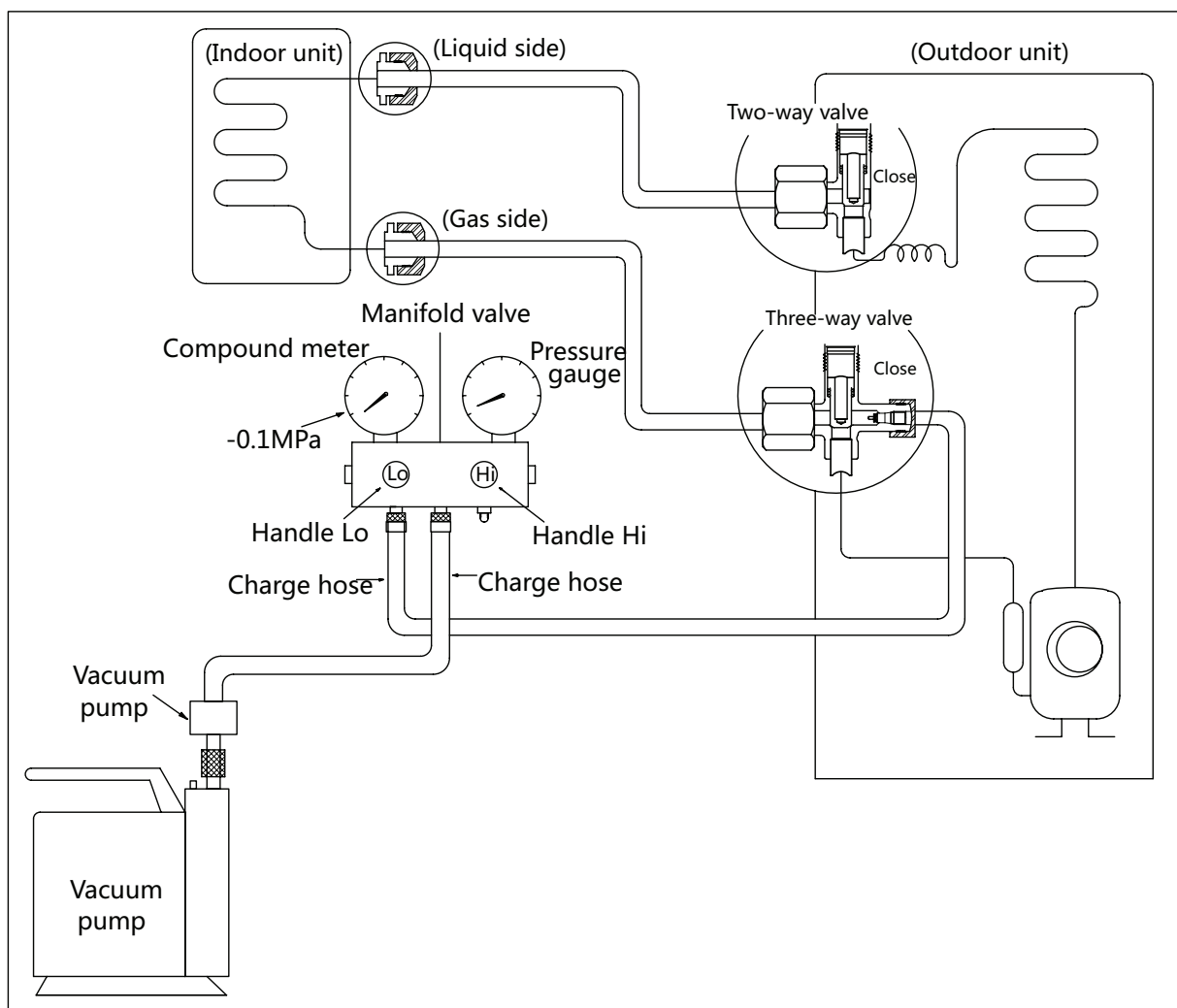

Procedure:

1. Tighten the flare nuts of the indoor and outdoor units, and confirm that both the 2- and 3-way valves are closed.
2. Connect the charge hose with the push pin of Handle Lo to the gas service port of the 3-way valve.
3. Connect the charge hose of Handle Hi connection to the vacuum pump.
4. Fully open the Handle Lo manifold valve.
5. Using the vacuum pump, evacuate the system for 30 minutes.
 - a. Check whether the compound meter indicates -0.1 MPa (14.5 Psi).
 - If the meter does not indicate -0.1 MPa (14.5 Psi) after 30 minutes, continue evacuating for an additional 20 minutes.
 - If the pressure does not achieve -0.1 MPa (14.5 Psi) after 50 minutes, check for leakage.
 - If the pressure successfully reaches -0.1 MPa (14.5 Psi), fully close the Handle Lo valve and cease vacuum pump operations.
 - b. Wait for 5 minutes then check whether the gauge needle moves after turning off the vacuum pump.
6. Loosen the flare nut of the 3-way valve for 6 or 7 seconds and then tighten the flare nut again.
 - c. Confirm the pressure display in the pressure indicator is slightly higher than the atmospheric pressure.
 - d. Remove the charge hose from the 3-way valve.
7. Fully open the 2- and 3-way valves and tighten the cap of the 3-way valve.

1.3.2 Outdoor Unit

Evacuation for the whole system

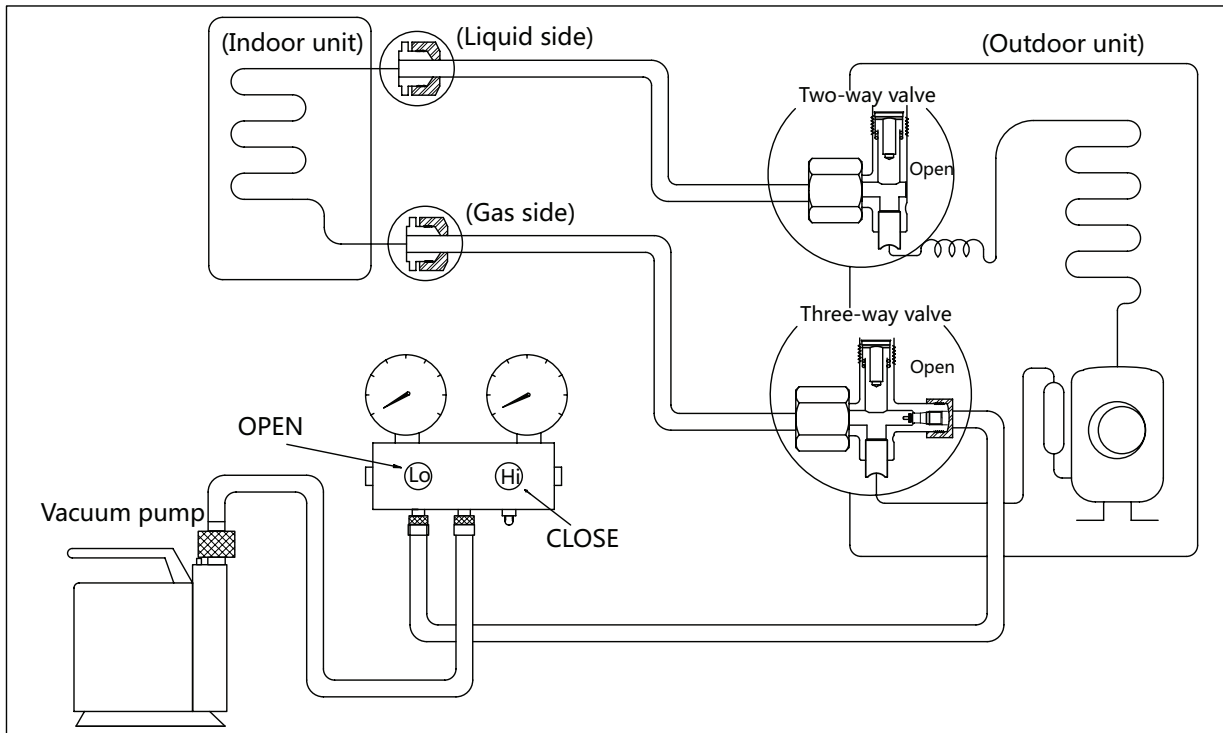

Procedure:

1. Confirm that the 2- and 3-way valves are opened.
2. Connect the vacuum pump to the 3-way valve's service port.
3. Evacuate the system for approximately one hour. Confirm that the compound meter indicates -0.1 MPa (14.5Psi).
4. Close the valve (Low side) on the charge set and turn off the vacuum pump.
5. Wait a period of five minutes then check whether the gauge needle moves after turning off the vacuum pump.
6. Disconnect the charge hose from the vacuum pump.

Refrigerant charging

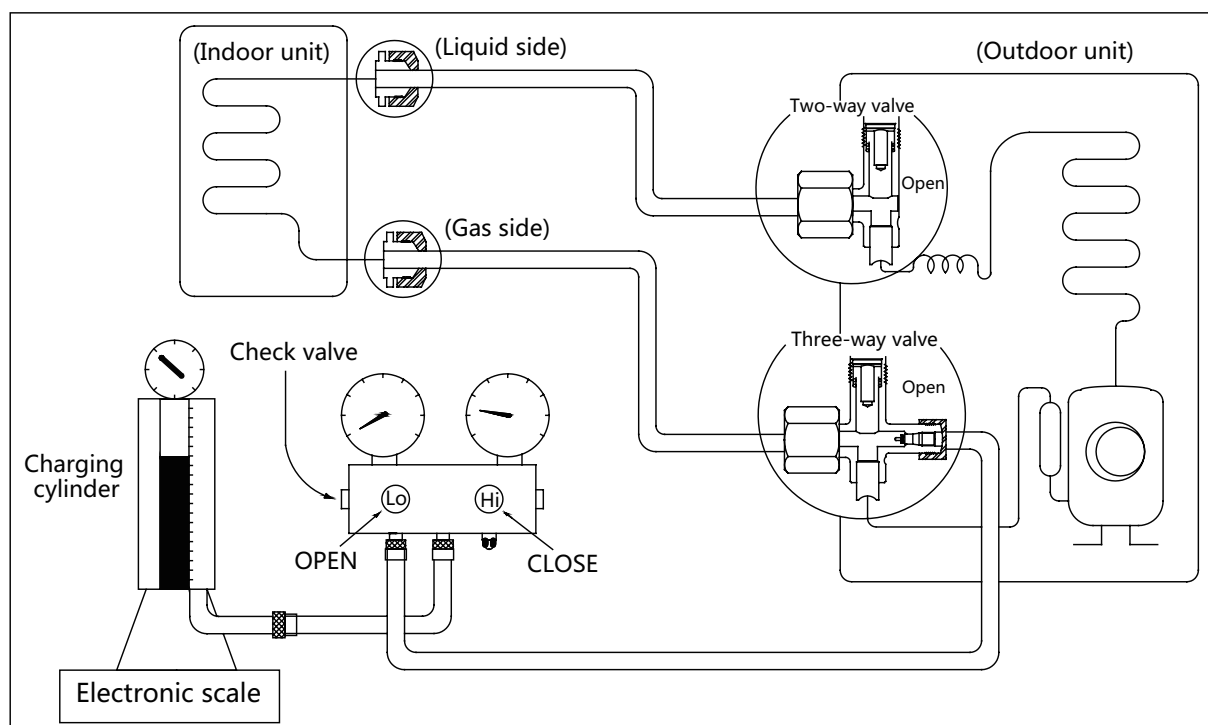

Procedure:

1. Connect the charge hose to the 3-way service port and then open the 2- and the 3-way valves.
2. Connect the charge hose to the valve at the bottom of the cylinder.
3. If the refrigerant is R410A, invert the cylinder to ensure a complete liquid charge.
4. Open the valve at the bottom of the cylinder and close the check valve on the charge set to purge the air.
5. Place the charging cylinder onto an electronic scale and record the starting weight.
6. Operate the air conditioner in cooling mode.
7. Open the valves (Low side) on the charge set and charge the system with liquid refrigerant.
8. When the electronic scale displays the correct weight (refer to the gauge and the pressure of the low side to confirm), disconnect the charge hose from the 3-way valve's service port immediately and turn off the air conditioner before disconnecting the hose.
9. Mount the valve stem caps and the service port.
10. Use a torque wrench to tighten the service port cap to a torque of 18 N.m.
11. Check for gas leakage.

Note: 1. Mechanical connectors used indoors shall comply with local regulations.

2. When mechanical connectors are reused indoors, sealing parts shall be renewed. When flared joints are reused indoors, the flare part shall be re-fabricated.

2. Disassembly

2.1 Indoor unit

1. Front Panel

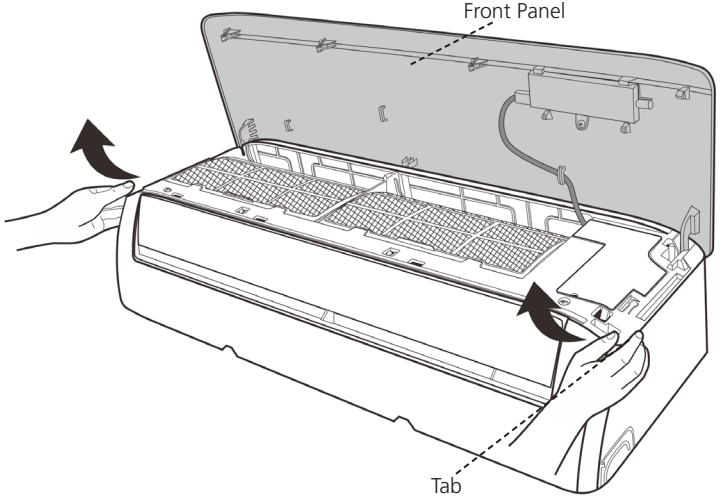
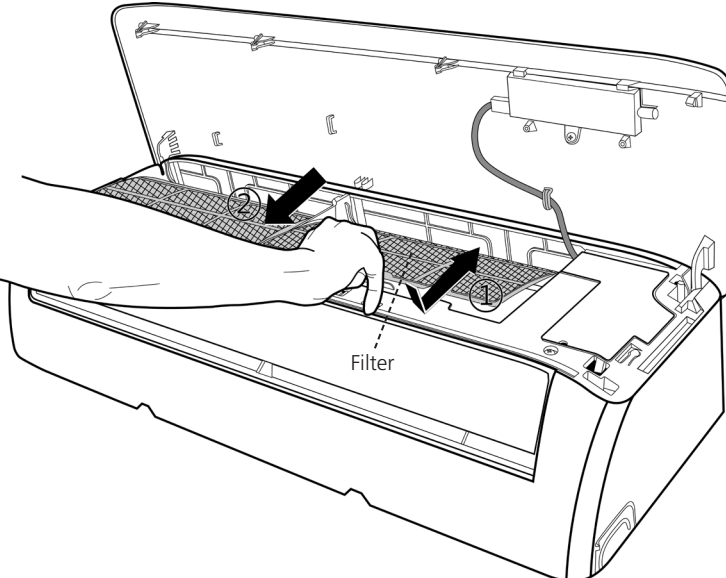
Procedure	Illustration
<p>1) Hold the front panel by the tabs on the both sides and lift it (see CJ_AB_INV_001).</p>	 <p style="text-align: center;">CJ_AB_INV_001</p>
<p>2) Push up the bottom of an air filter (step 1), and then pull it out downwards (step 2) (see CJ_AB_INV_002).</p>	 <p style="text-align: center;">CJ_AB_INV_002</p>

Note: This section is for reference only. Actual unit appearance may vary.

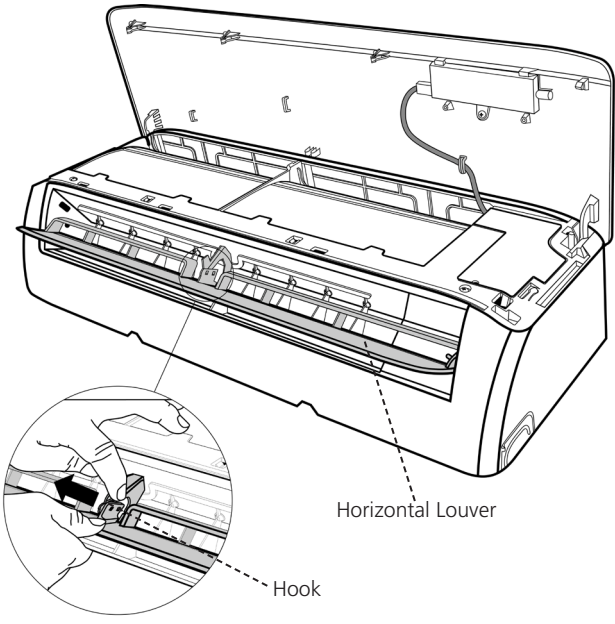
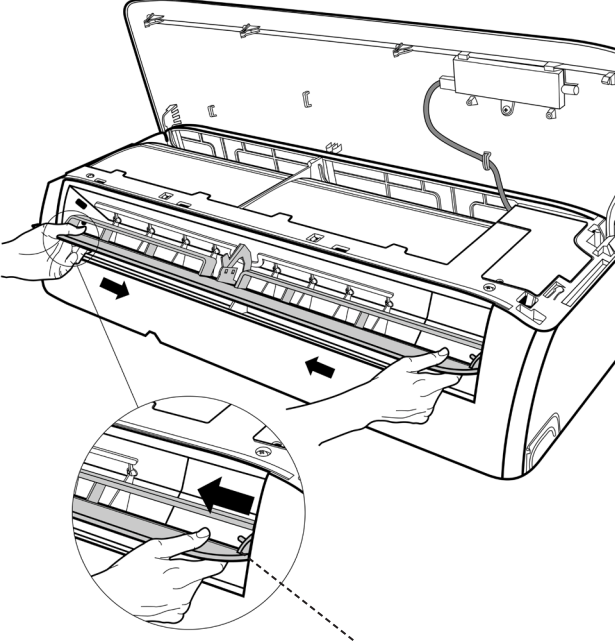
Procedure	Illustration
<p>3) Open the horizontal louver and push the hook towards left to open it (see CJ_AB_INV_003).</p>	 <p style="text-align: center;">CJ_AB_INV_003</p>
<p>4) Bend the horizontal louver lightly by both hands to loosen the hooks, then remove the horizontal louver (see CJ_AB_INV_004).</p>	 <p style="text-align: center;">CJ_AB_INV_004</p>

Note: This section is for reference only. Actual unit appearance may vary.

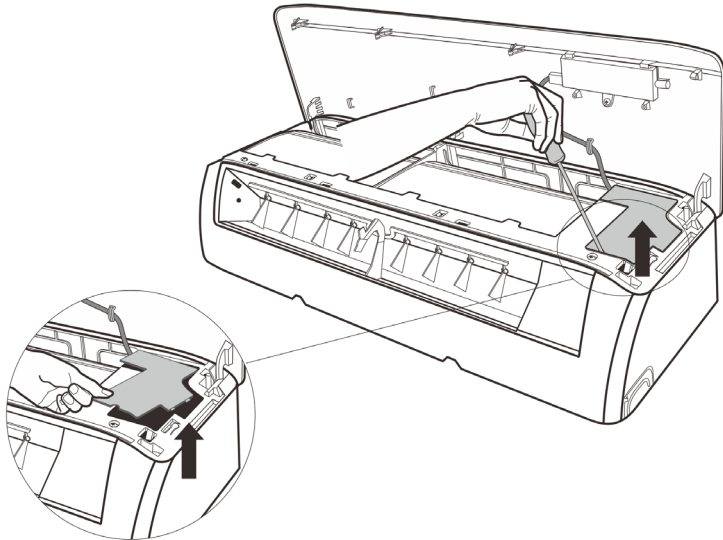
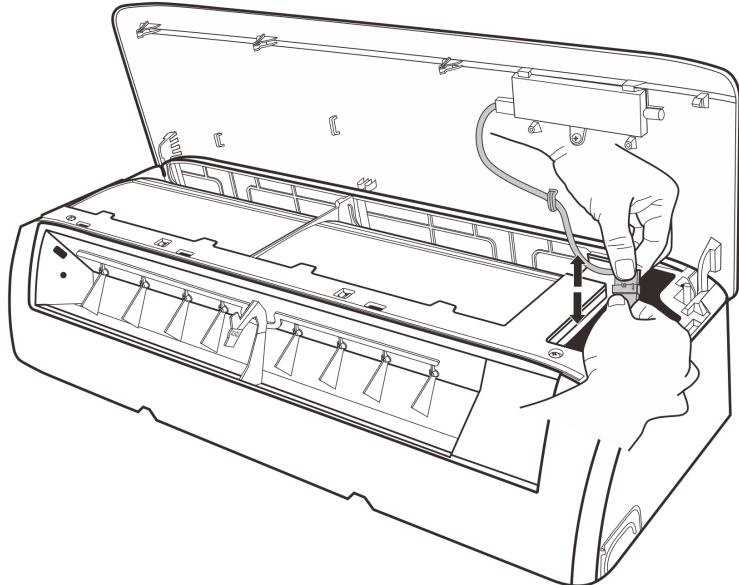
Procedure	Illustration
<p>5) Pry the electrical cover by a screw driver, and rotate it towards left, then remove it. (see CJ_AB_INV_005).</p>	 <p style="text-align: center;">CJ_AB_INV_005</p>
<p>6) Disconnect the connector for display board. (see CJ_AB_INV_006) .</p>	 <p style="text-align: center;">CJ_AB_INV_006</p>

Note: This section is for reference only. Actual unit appearance may vary.

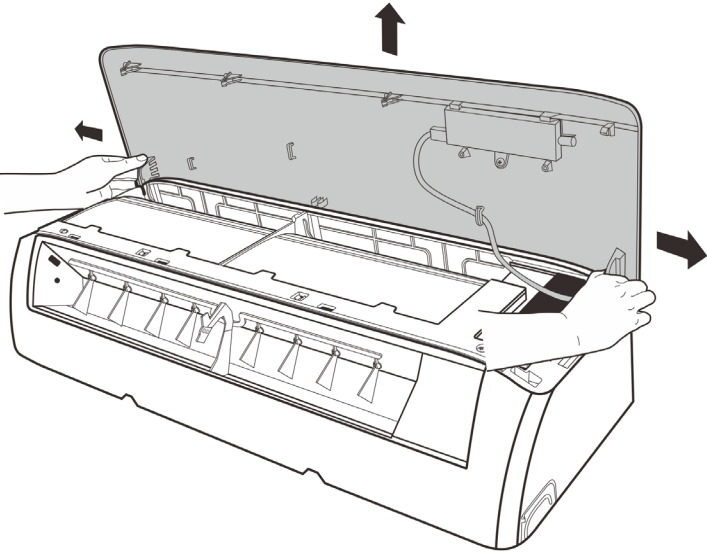
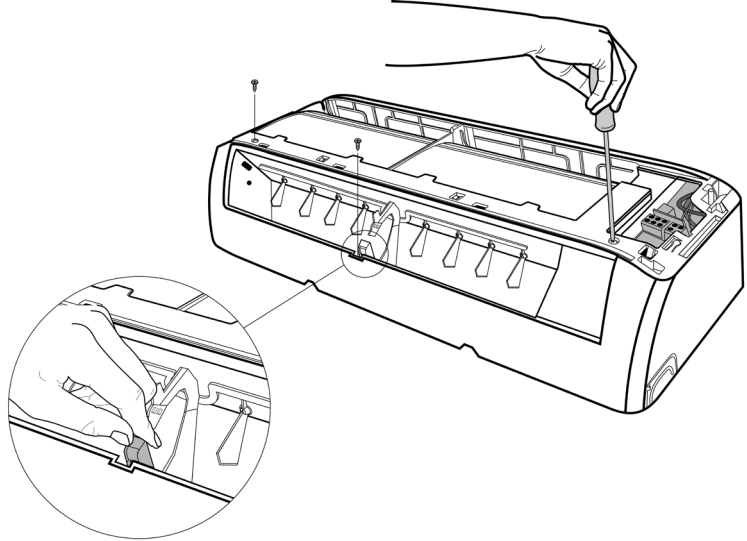
Procedure	Illustration
<p>7) Slid the front panel side to side to release each axis (see CJ_AB_INV_007)</p>	 <p>The diagram shows a hand on the left side of the front panel, pushing it to the left. Another hand on the right side is pushing the front panel to the right. An upward-pointing arrow above the panel indicates it is being lifted. The internal components, including the axes and a motor, are visible.</p> <p>CJ_AB_INV_007 CJ_AF_INV_011-1</p>
<p>8) Open the screw cap and then remove the 3 screws (see CJ_AB_INV_008).</p>	 <p>The diagram shows a hand using a screwdriver to remove a screw from the top of the front panel. A circular inset provides a magnified view of the screwdriver tip being used to pry open a screw cap. Three screws are shown being removed from the top of the panel.</p> <p>CJ_AB_INV_008</p>

Note: This section is for reference only. Actual unit appearance may vary.

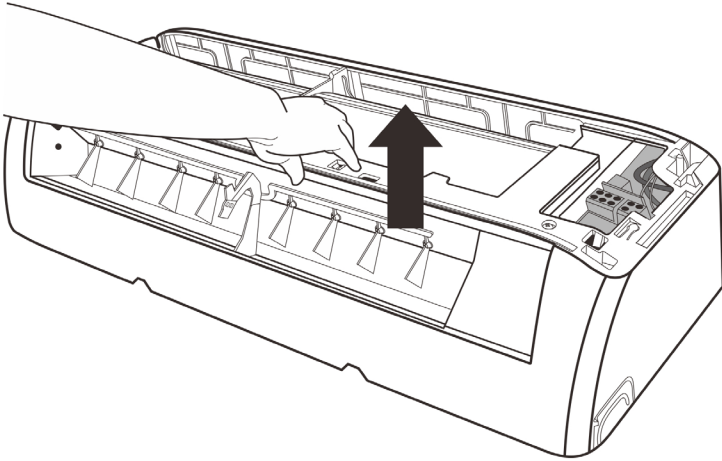
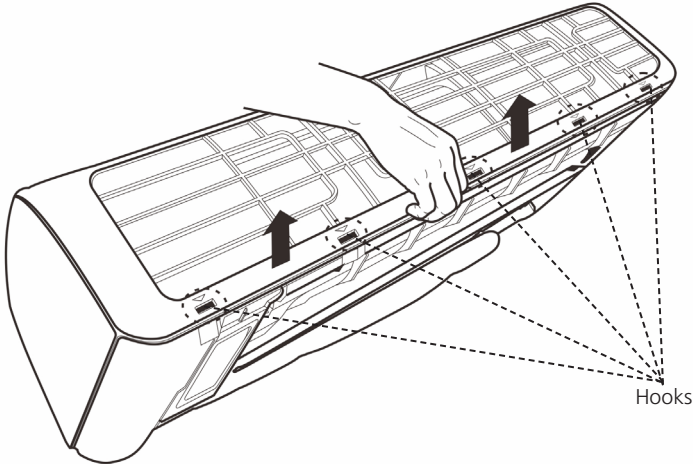
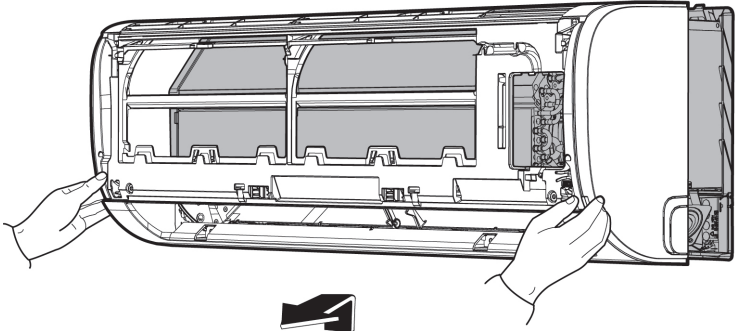
Procedure	Illustration
<p>9) Release the hooks with hands. (see CJ_AB_INV_009)</p>	 <p style="text-align: center;">CJ_AB_INV_009</p>
<p>10) Release the 5 hooks in the back (see CJ_AB_INV_010).</p>	 <p style="text-align: right;">Hooks</p> <p style="text-align: center;">CJ_AB_INV_010</p>
<p>11) Pull out the panel frame while pushing the hook through a clearance between the panel frame and the heat exchanger. (see CJ_AB_INV_011)</p>	 <p style="text-align: center;">CJ_AB_INV_011</p>

Note: This section is for reference only. Actual unit appearance may vary.

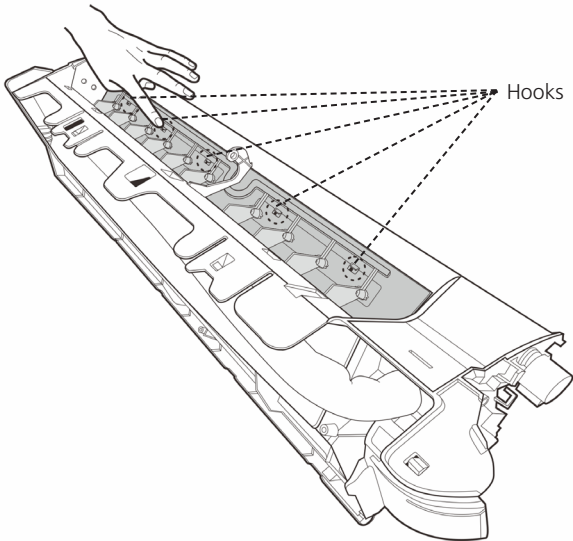
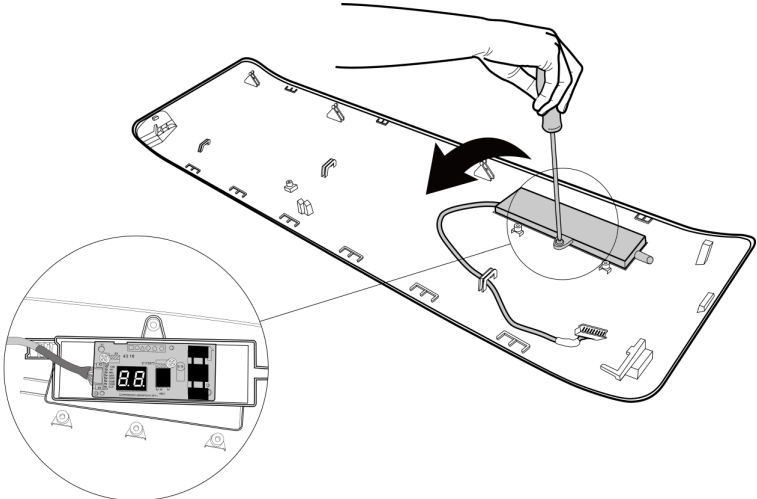
Procedure	Illustration
<p>12) Release the 5 hooks of the vertical blades, then pull the vertical blades rightward and remove it (see CJ_AB_INV_012).</p>	 <p style="text-align: center;">CJ_AB_INV_012</p>
<p>13) Remove 1 screw of the display board. (see CJ_AB_INV_013).</p> <p>14) Rotate the display board in the direction shown in the right picture. (see CJ_AB_INV_013).</p>	 <p style="text-align: center;">CJ_AB_INV_013</p>

Note: This section is for reference only. Actual unit appearance may vary.

2. Electrical parts (Antistatic gloves must be worn.)

Note: Remove the front panel (refer to 1. Front panel) before disassembling electrical parts.

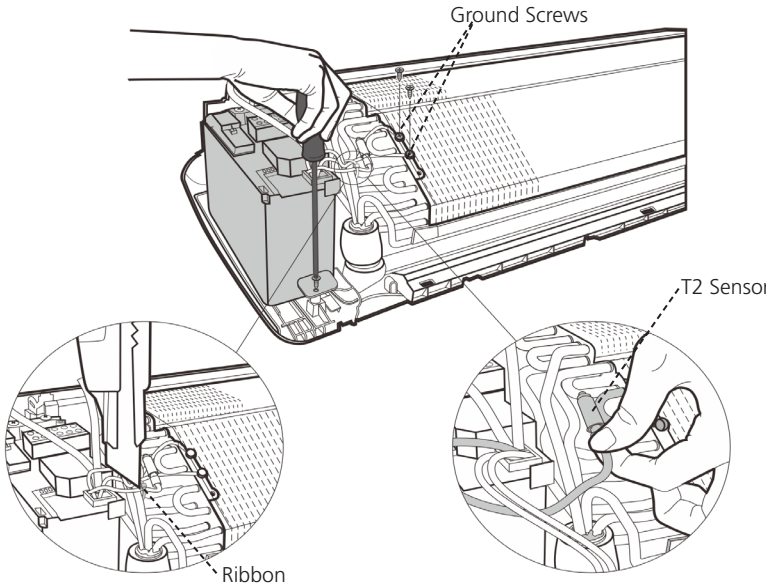
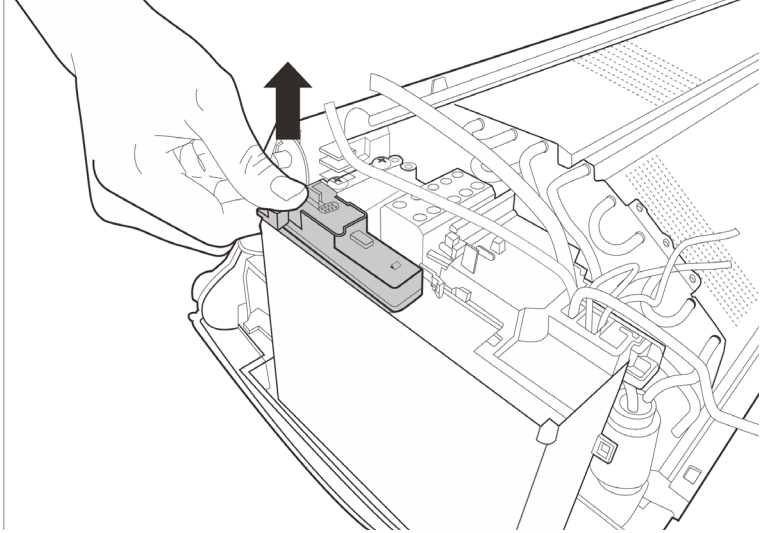
Procedure	Illustration
<p>1) Cut the ribbon by a shear, then pull out the coil temperature sensor (T2) (see CJ_AB_INV_014).</p> <p>2) Remove one fixing screw of the electronic control box and two screws used for the ground connection (see CJ_AB_INV_014).</p>	 <p style="text-align: center;">CJ_AB_INV_014</p>
<p>3) An upward force is maintained until the cover of electronic control box is removed (see CJ_AB_INV_015).</p>	 <p style="text-align: center;">CJ_AB_INV_015</p>

Note: This section is for reference only. Actual unit appearance may vary.

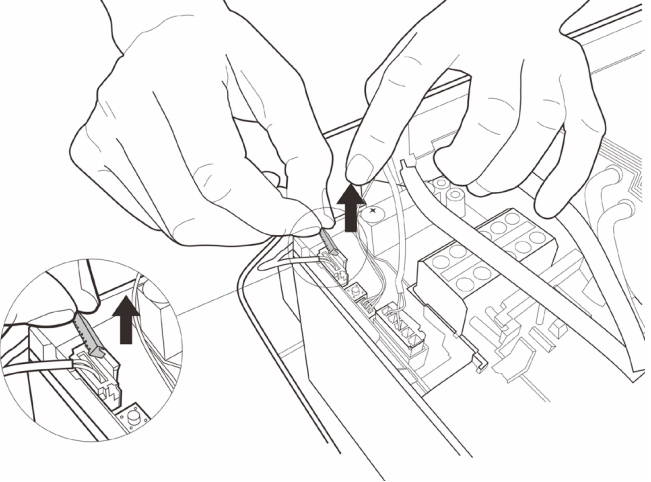
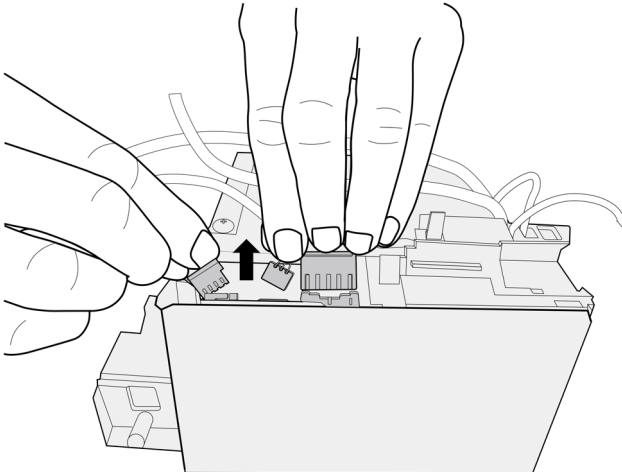
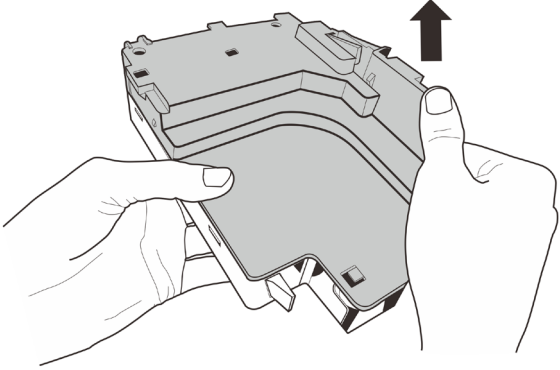
Procedure	Illustration
<p>4) Remove the fixed devices of the connectors (see CJ_AB_INV_016).</p>	 <p style="text-align: center;">CJ_AB_INV_016</p>
<p>5) Disconnect the connectors of fan motor, the step motor and the T2 sensor (see CJ_AB_INV_017).</p>	 <p style="text-align: center;">CJ_AB_INV_017</p>
<p>6) Open the left side plate of electronic control box (see CJ_AB_INV_018).</p>	 <p style="text-align: center;">CJ_AB_INV_018</p>

Note: This section is for reference only. Actual unit appearance may vary.

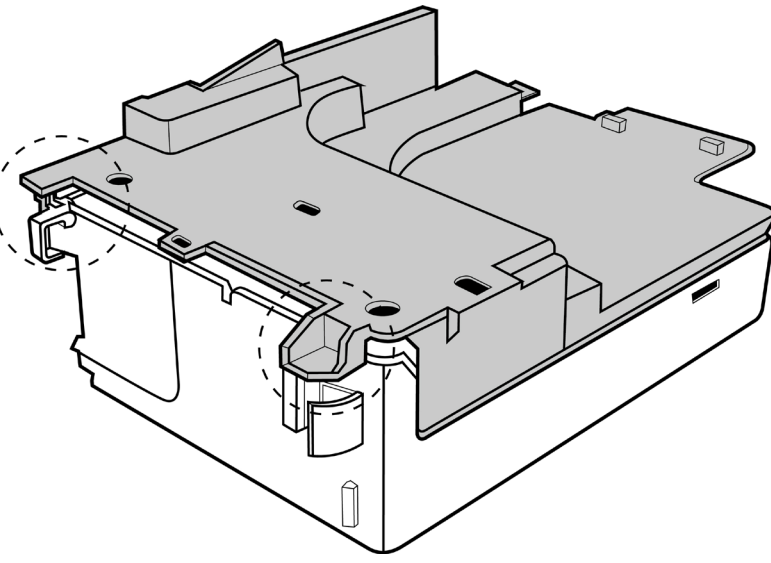
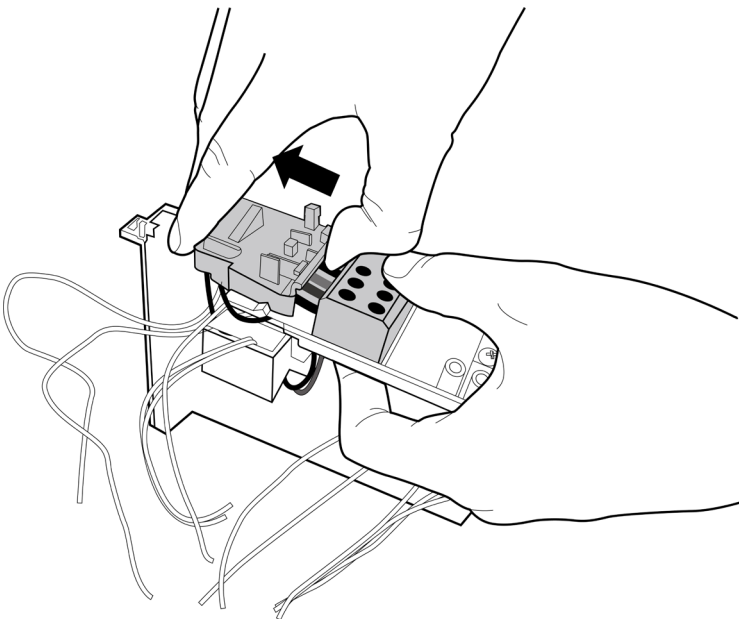
Procedure	Illustration
<p>7) Open the two clips on the front of the electric box. (see CJ_AB_INV_019)</p>	 <p style="text-align: center;">CJ_AB_INV_019</p>
<p>8) Open the upper cover plate of electronic control box (see CJ_AB_INV_020).</p>	 <p style="text-align: center;">CJ_AB_INV_020</p>

Note: This section is for reference only. Actual unit appearance may vary.

Procedure	Illustration
<p>9) Remove 1 screw and open the 2 clips along the direction indicated in right image (see CJ_AB_INV_021).</p>	<p style="text-align: center;">CJ_AB_INV_021</p>
<p>10) Pull out the electrical main board along the direction indicated in right image to remove it (see CJ_AB_INV_022).</p>	<p style="text-align: center;">CJ_AB_INV_022</p>

Note: This section is for reference only. Actual unit appearance may vary.

3. Evaporator

Note: Remove the front panel and electrical parts (refer to 1. Front panel and 2. Electrical parts) before disassembling evaporator.

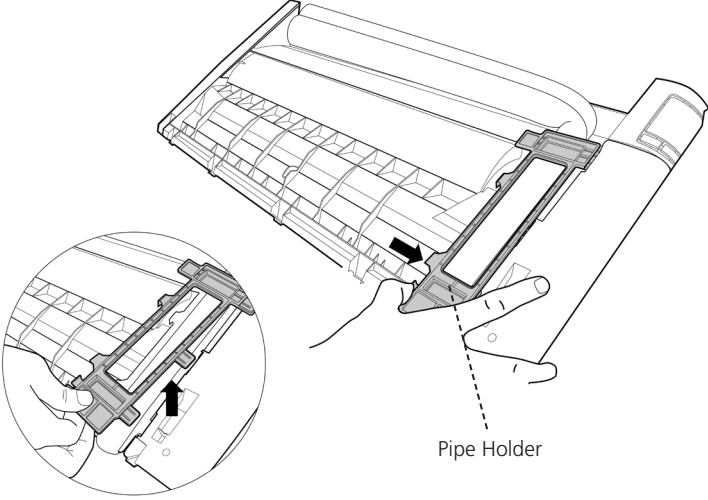
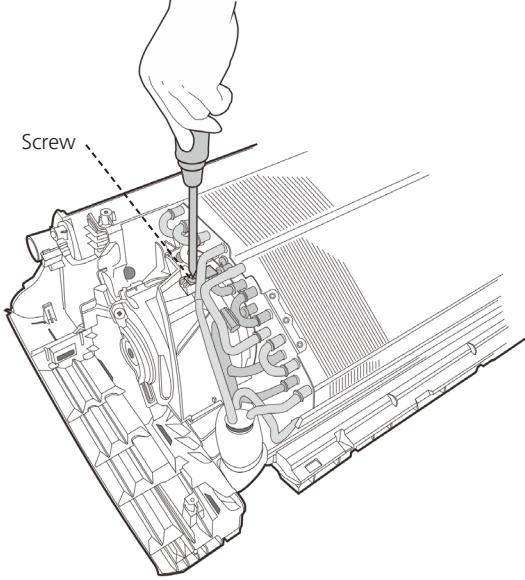
Procedure	Illustration
1) Disassemble the pipe holder located at the rear of the unit (see CJ_AB_INV_023).	 <p style="text-align: center;">CJ_AB_INV_023</p>
2) Remove the 1 screws on the evaporator located at the fixed plate (see CJ_AB_INV_024).	 <p style="text-align: center;">CJ_AB_INV_024</p>

Note: This section is for reference only. Actual unit appearance may vary.

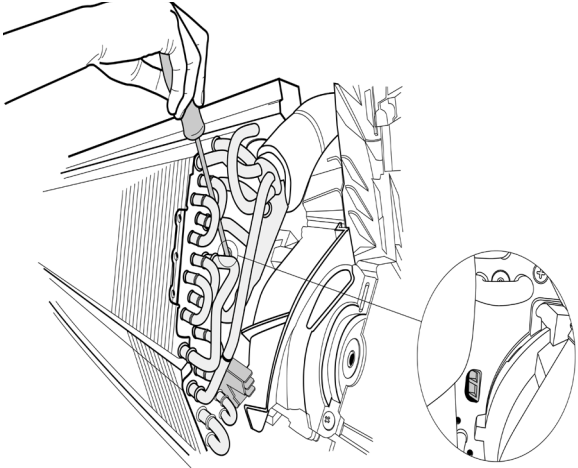
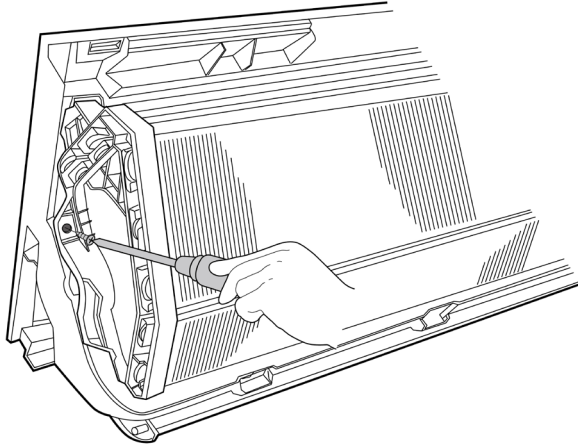
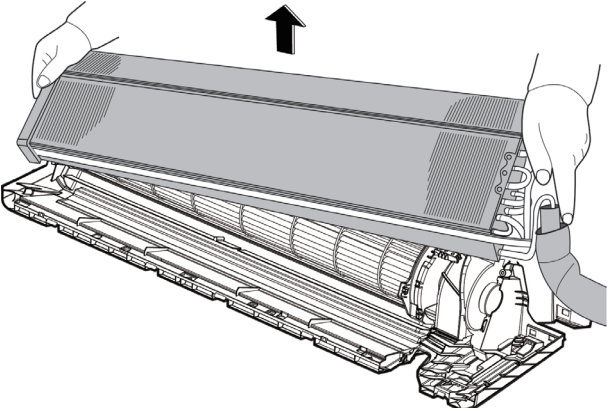
Procedure	Illustration
<p>3) Release the hook on the evaporator (see CJ_AB_INV_025).</p>	 <p style="text-align: center;">CJ_AB_INV_025</p>
<p>4) Remove the one screw on the evaporator located at the fixed plate (see CJ_AB_INV_026).</p>	 <p style="text-align: center;">CJ_AB_INV_026</p>
<p>5) Pull out the evaporator (see CJ_AB_INV_027).</p>	 <p style="text-align: center;">CJ_AB_INV_027</p>

Note: This section is for reference only. Actual unit appearance may vary.

4. Fan motor and fan

Note: Remove the front panel, electrical parts and evaporator (refer to 1. Front panel, 2. Electrical parts, and 3. Evaporator). before disassembling fan motor and fan.

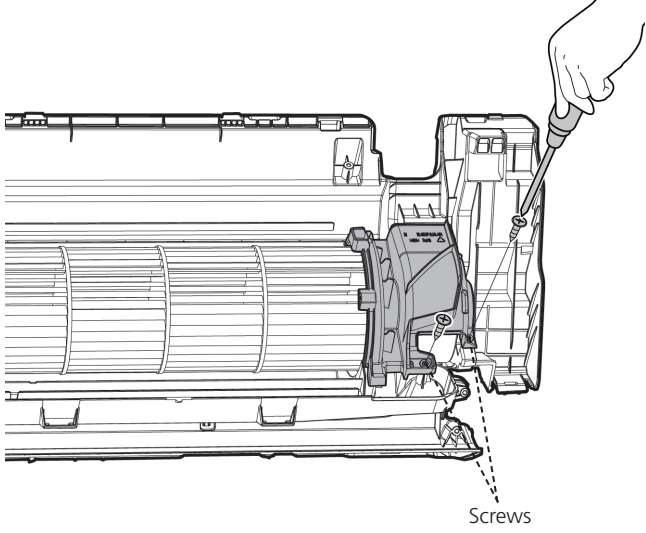
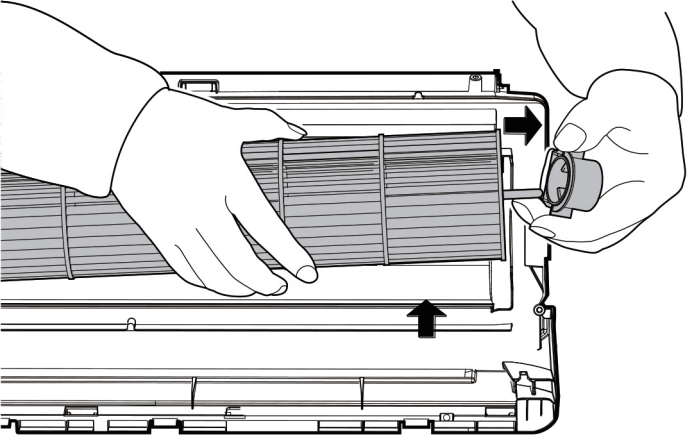
Procedure	Illustration
1) Remove the two screws and remove the fixing board of the fan motor (see CJ_AB_INV_028).	 <p style="text-align: center;">CJ_AB_INV_028</p>
2) Remove the bearing sleeve (see CJ_AB_INV_029).	 <p style="text-align: center;">CJ_AB_INV_029</p>

Note: This section is for reference only. Actual unit appearance may vary.

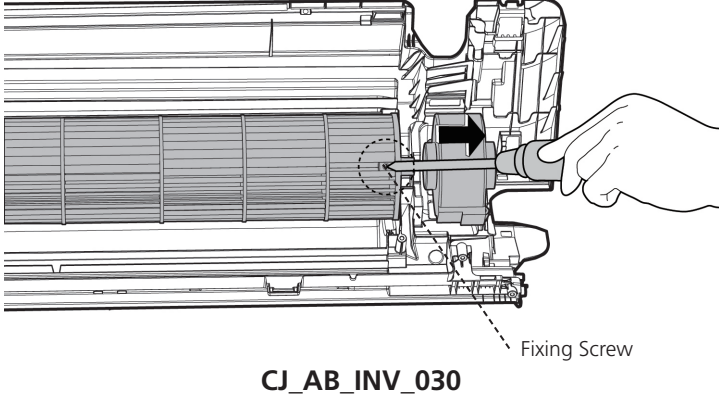
Procedure	Illustration
<p>3) Remove the fixing screw (see CJ_AB_INV_030).</p> <p>4) Pull out the fan motor and fan assembly from the side.</p>	 <p>CJ_AB_INV_030</p>

Note: This section is for reference only. Actual unit appearance may vary.

5. Step motor

Note: Remove the front panel and electrical parts (refer to 1. Front panel, 2. Electrical parts) before disassembling step motor.

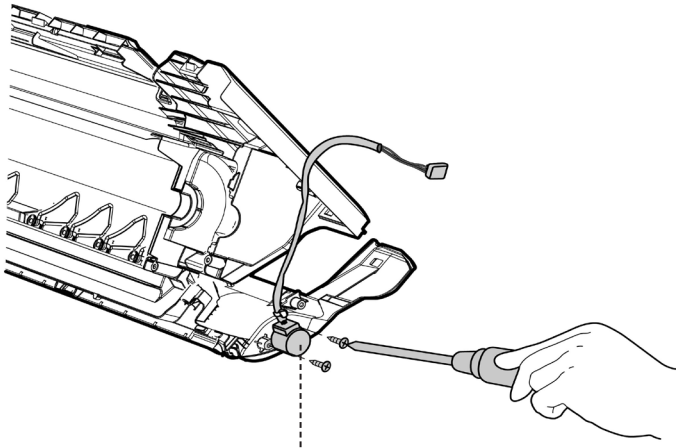
Procedure	Illustration
1) Remove the two screws, then remove the stepping motor (see CJ_AB_INV_031).	 <p>The illustration shows a hand using a screwdriver to remove a screw from the stepping motor. A dashed line points to the motor, which is labeled "Stepping Motor". The device is shown in a partially disassembled state, with the front panel and electrical parts removed. The reference code "CJ_AB_INV_031" is printed below the illustration.</p>

Note: This section is for reference only. Actual unit appearance may vary.

6. Drain Hose

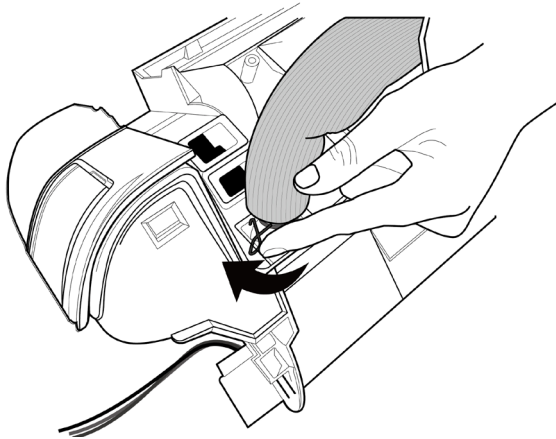
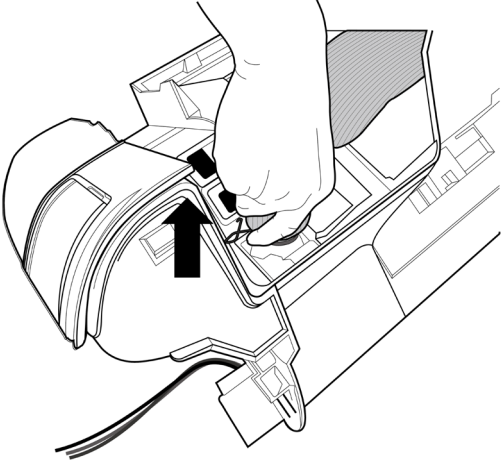
Procedure	Illustration
1) Rotate the fixed wire clockwise indicated in right image (see CJ_AB_INV_032).	 <p data-bbox="938 922 1141 958">CJ_AB_INV_032</p>
2) Pull up the drain hose to remove it (see CJ_AB_INV_033).	 <p data-bbox="938 1482 1141 1518">CJ_AB_INV_033</p>

Note: This section is for reference only. Actual unit appearance may vary.

2.2 Outdoor unit

1. Panel Plate

MOBA30-09CFN1-BP0W,MOBA30-09CFN1-MP0W,MOBA30-09HDN1-BQ0W,MOBA30-09HDN1-MQ0W

MOBA30-12CFN1-BP0W,MOBA30-12CFN1-MP0W,MOBA30-12HDN1-BQ0W,MOBA30-12HDN1-MQ0W

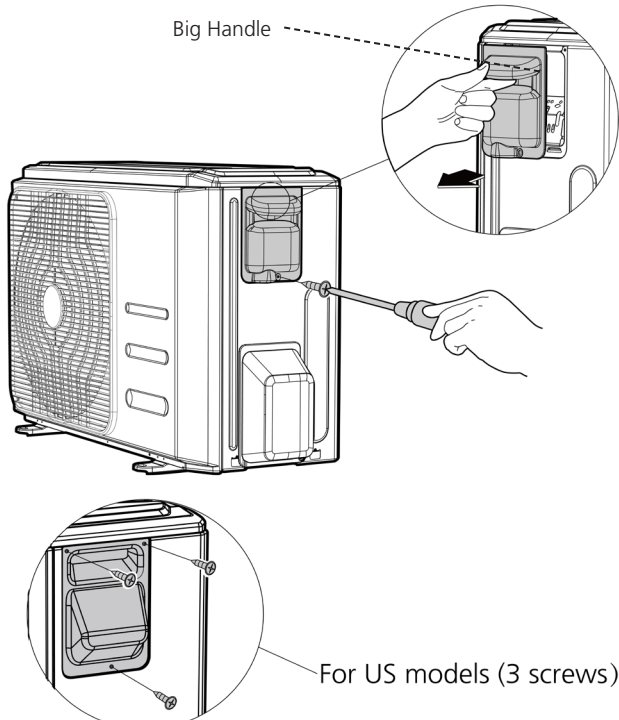
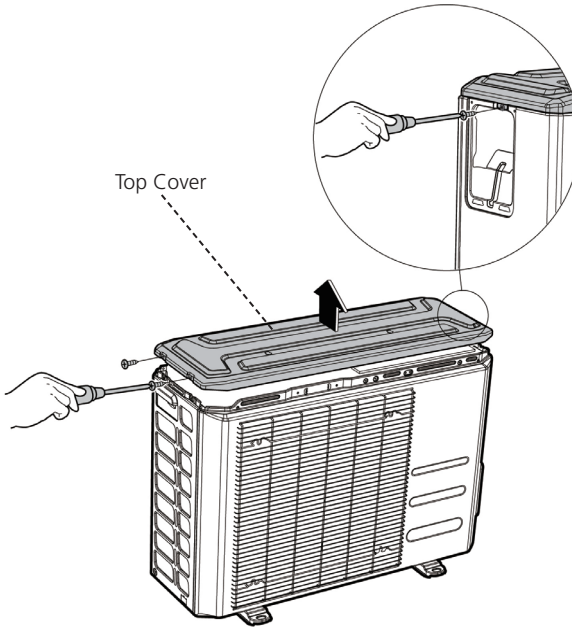
Procedure	Illustration
<p>1) Turn off the air conditioner and the power breaker.</p> <p>2) Remove the screws of the big handle and then remove the big handle (1 screws) (see CJ_BA30_001).</p>	 <p>CJ_BA30_001</p>
<p>3) Remove the screws of the top cover and then remove the top cover (3 screws). One of the screws is located underneath the big handle (see CJ_BA30_002).</p>	 <p>CJ_BA30_002</p>

Note: This section is for reference only. Actual unit appearance may vary.

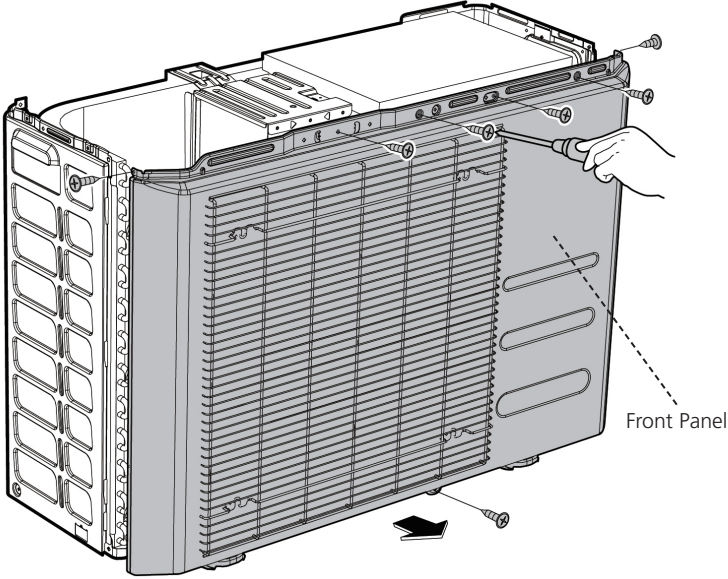
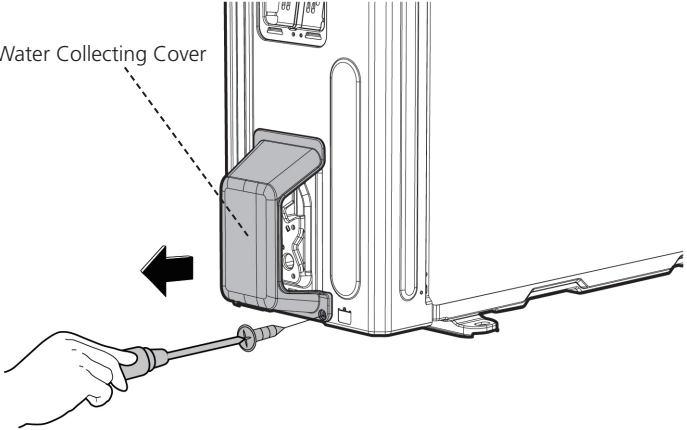
Procedure	Illustration
<p>4) Remove the screws of the front panel and then remove the front panel (7 screws) (see CJ_BA30_003).</p>	 <p>CJ_BA30_003</p>
<p>5) Remove the screws of water collecting cover (1 screw) (see CJ_BA30_004).</p>	 <p>CJ_BA30_004</p>

Note: This section is for reference only. Actual unit appearance may vary.

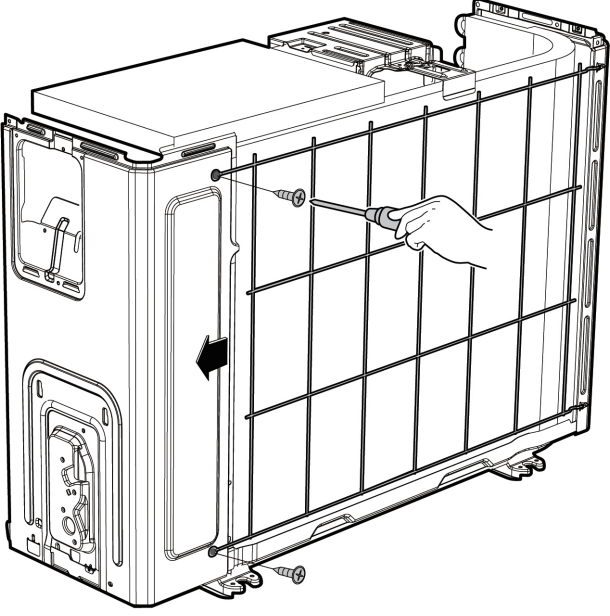
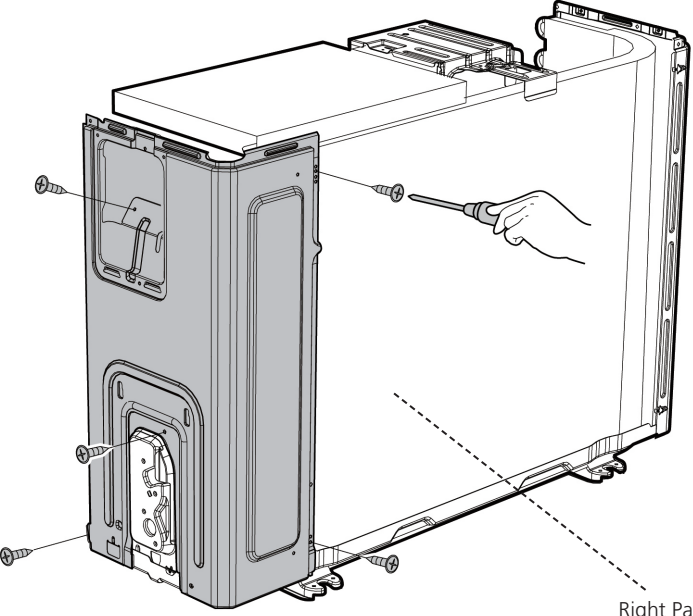
Procedure	Illustration
<p>6) Remove the screws of the rear net and then remove the rear net (2 screws) (see CJ_BA30_005).</p>	 <p style="text-align: center;">CJ_BA30_005</p>
<p>7) Remove the screws of the right panel and then remove the right panel (5 screws) (see CJ_BA30_006).</p>	 <p style="text-align: right;">Right Panel</p> <p style="text-align: center;">CJ_BA30_006</p>

Note: This section is for reference only. Actual unit appearance may vary.

MOB30-17CFN1-MQ0W, MOB30-18HDN1-MQ0W:

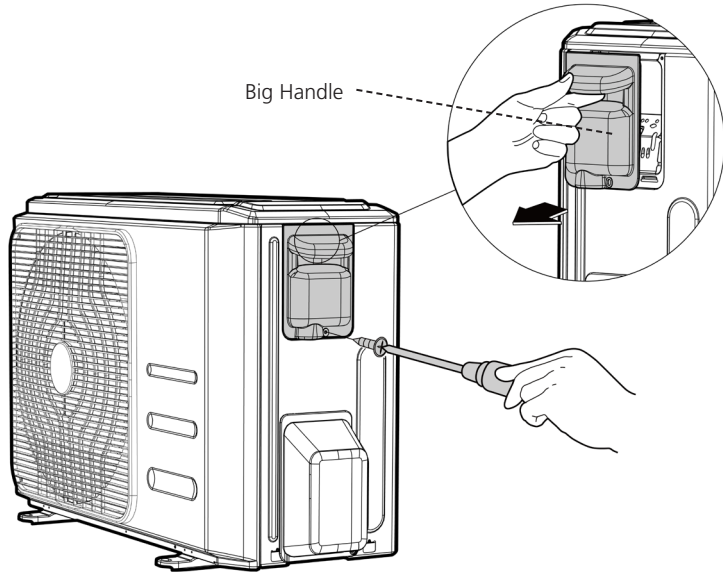
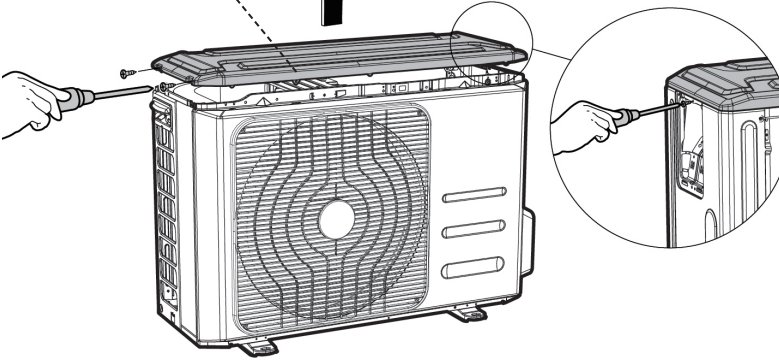
Procedure	Illustration
<p>1) Turn off the air conditioner and the power breaker.</p> <p>2) Remove the screws of the big handle and then remove the big handle (3 screws) (see CJ_B30_INV_001).</p>	 <p>Big Handle</p> <p>For US models (3 screws)</p> <p>CJ_B30_INV_001</p>
<p>3) Remove the screws of the top cover and then remove the top cover (3 screws). One of the screws is located underneath the big handle (see CJ_B30_INV_002).</p>	 <p>Top Cover</p> <p>CJ_B30_INV_002</p>

Note: This section is for reference only. Actual unit appearance may vary.

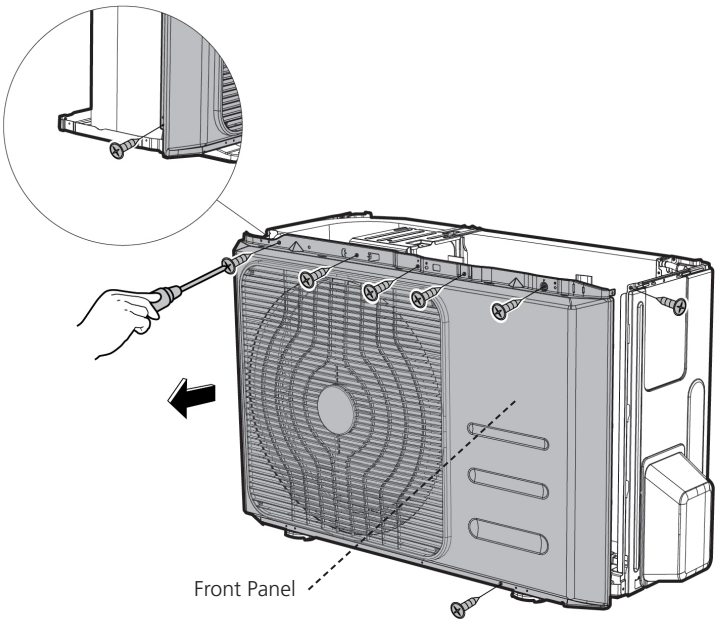
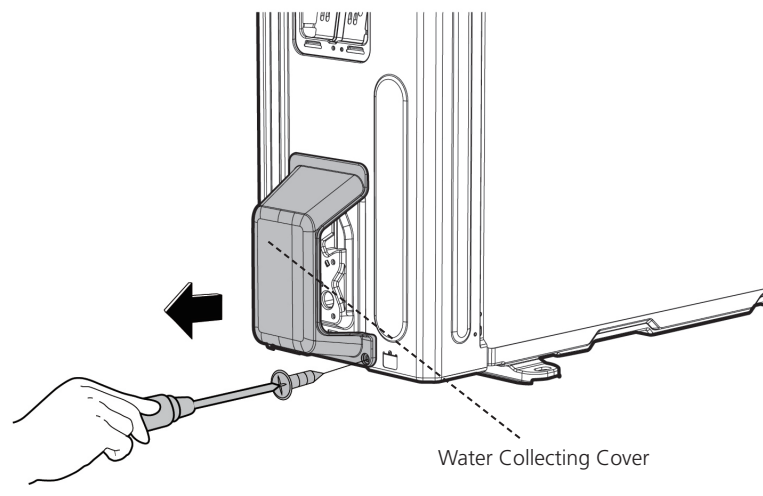
Procedure	Illustration
<p>4) Remove the screws of the front panel and then remove the front panel (8 screws) (see CJ_B30_INV_003).</p>	 <p style="text-align: center;">CJ_B30_INV_003</p>
<p>5) Remove the screws of water collecting cover and then remove the water collecting cover (1 screw) (see CJ_B30_INV_004).</p>	 <p style="text-align: center;">CJ_B30_INV_004</p>

Note: This section is for reference only. Actual unit appearance may vary.

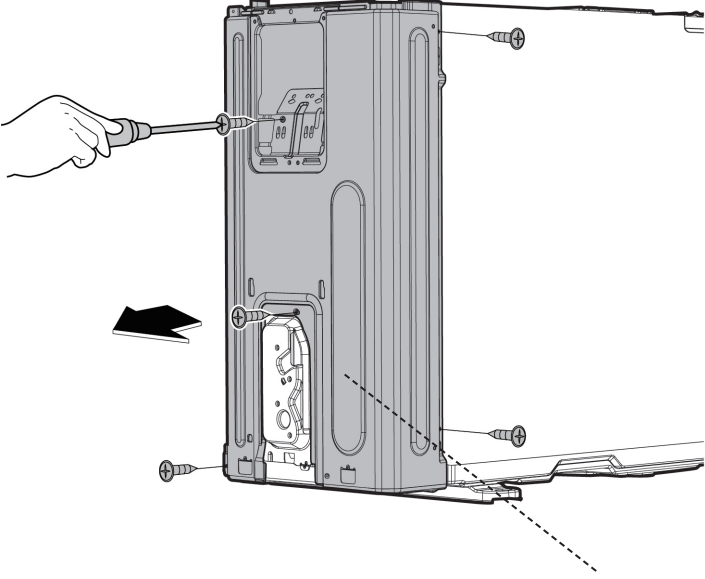
Procedure	Illustration
<p>6) Remove the screws of the right panel and then remove the right panel (5 screws) (see CJ_B30_INV_005).</p>	 <p>CJ_B30_INV_005</p> <p>Right Panel</p>

Note: This section is for reference only. Actual unit appearance may vary.

MOCA30-23CFN1-MP0W, MOCA30-23HDN1-MQ0W:

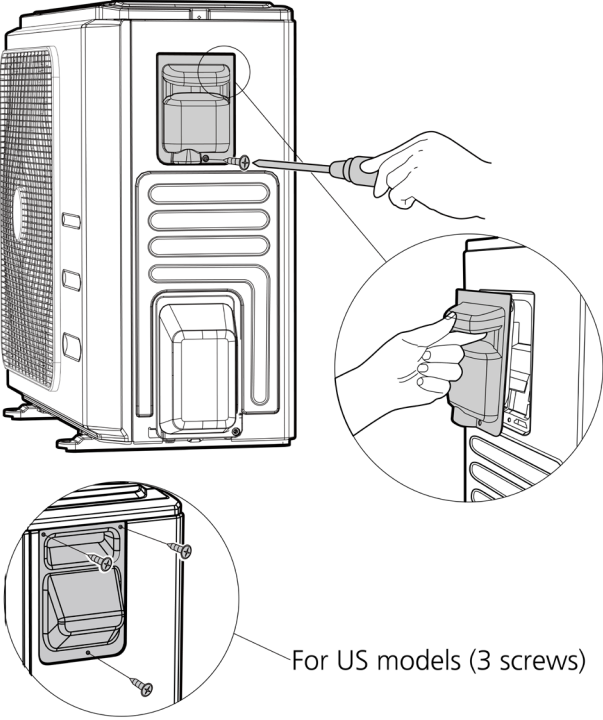
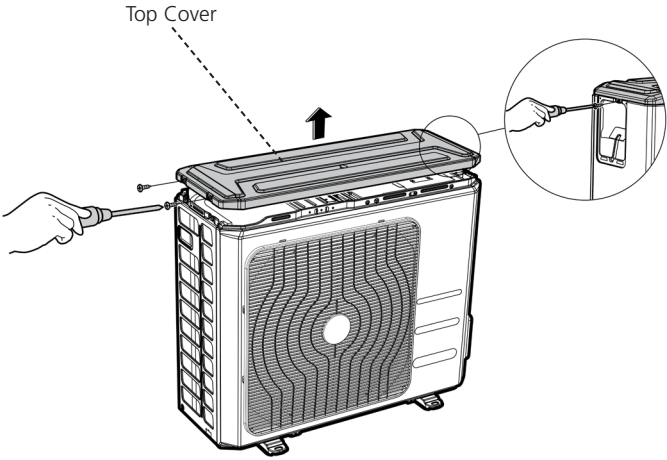
Procedure	Illustration
<p>1) Turn off the air conditioner and the power breaker.</p> <p>2) Remove the screws of the big handle and then remove the big handle (3 screws) (see CJ_CA30_INV_001).</p>	 <p>For US models (3 screws)</p> <p>CJ_CA30_INV_001</p>
<p>3) Remove the screws of the top cover and then remove the top cover (3 screws). One of the screws is located underneath the big handle (see CJ_CA30_INV_002).</p>	 <p>Top Cover</p> <p>CJ_CA30_INV_002</p>

Note: This section is for reference only. Actual unit appearance may vary.

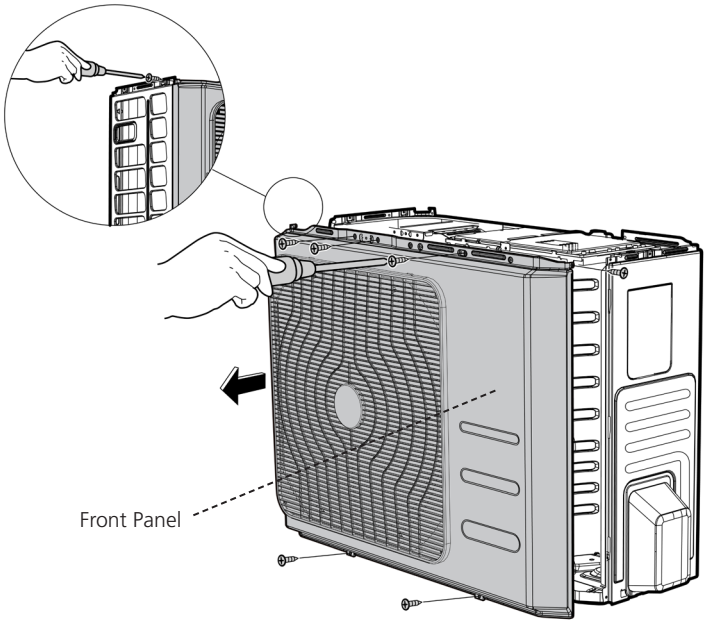
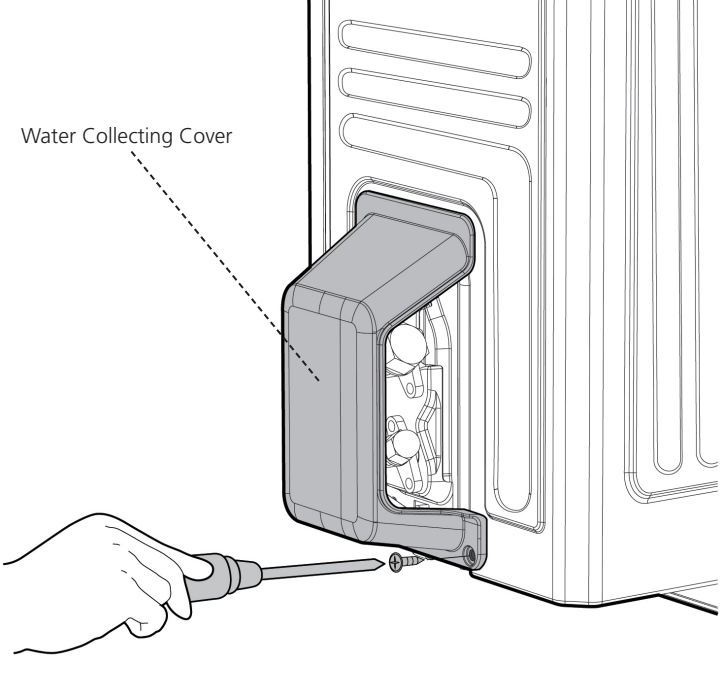
Procedure	Illustration
<p>4) Remove the screws of the front panel and then remove the front panel (7 screws) (see CJ_CA30_INV_003).</p>	 <p style="text-align: center;">CJ_CA30_INV_003</p>
<p>5) Remove the screws of water collecting cover and then remove the water collecting cover (1 screw) (see CJ_CA30_INV_004).</p>	 <p style="text-align: center;">CJ_CA30_INV_004</p>

Note: This section is for reference only. Actual unit appearance may vary.

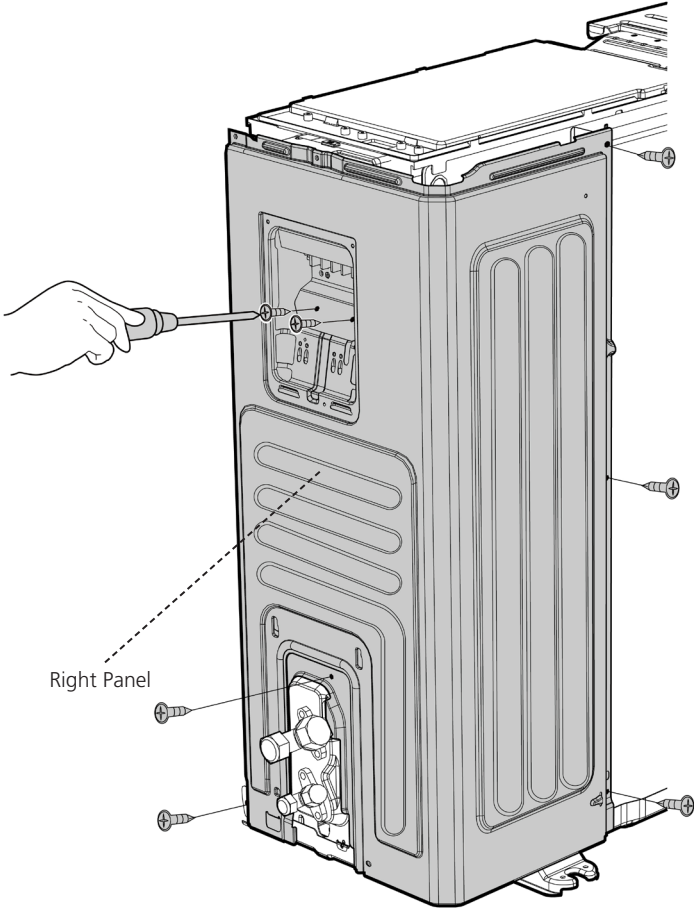
Procedure	Illustration
<p>6) Remove the screws of the right panel and then remove the right panel (6 screws) (see CJ_CA30_INV_005).</p>	 <p>The illustration shows a hand using a screwdriver to remove screws from the right panel of a unit. The unit is shown in a three-quarter view, with the right panel being the focus. A dashed line points to the right panel, and a label 'Right Panel' is placed next to it. The unit has a control panel on the left side and a large panel on the right side. The right panel is being removed, and the screws are being shown being removed. The unit is labeled 'CJ_CA30_INV_005' at the bottom.</p> <p data-bbox="900 1375 1134 1406">CJ_CA30_INV_005</p>

Note: This section is for reference only. Actual unit appearance may vary.

MOD30-30HFN1-MR0W, MOD30-36HFN1-MP0W:

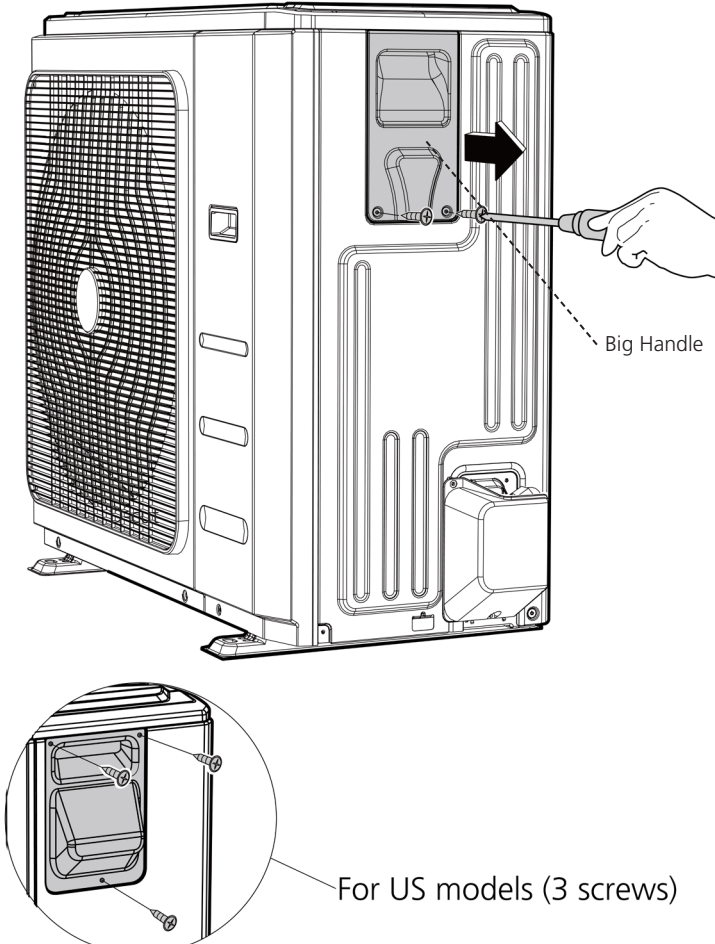
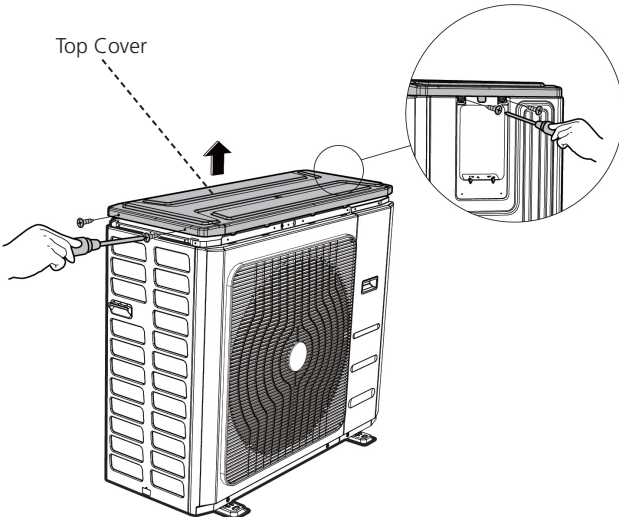
Procedure	Illustration
<p>1) Turn off the air conditioner and the power breaker.</p> <p>2) Remove the screws of the big handle and then remove the big handle (2 screws) (see CJ_D30_INV_001).</p>	 <p style="text-align: center;">CJ_D30_INV_001</p>
<p>3) Remove the screws of the top cover and then remove the top cover (4 screws). Two of the screws is located underneath the big handle (see CJ_D30_INV_002).</p>	 <p style="text-align: center;">CJ_D30_INV_002</p>

Note: This section is for reference only. Actual unit appearance may vary.

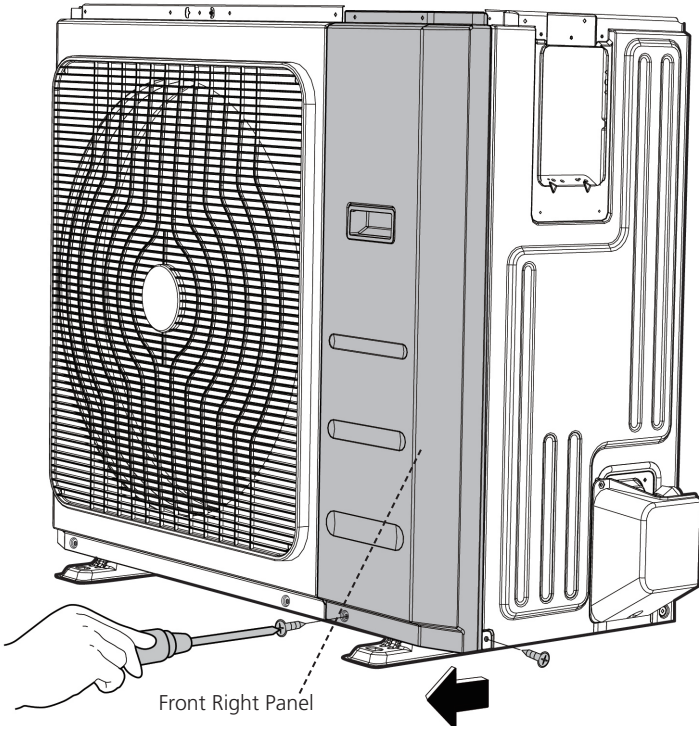
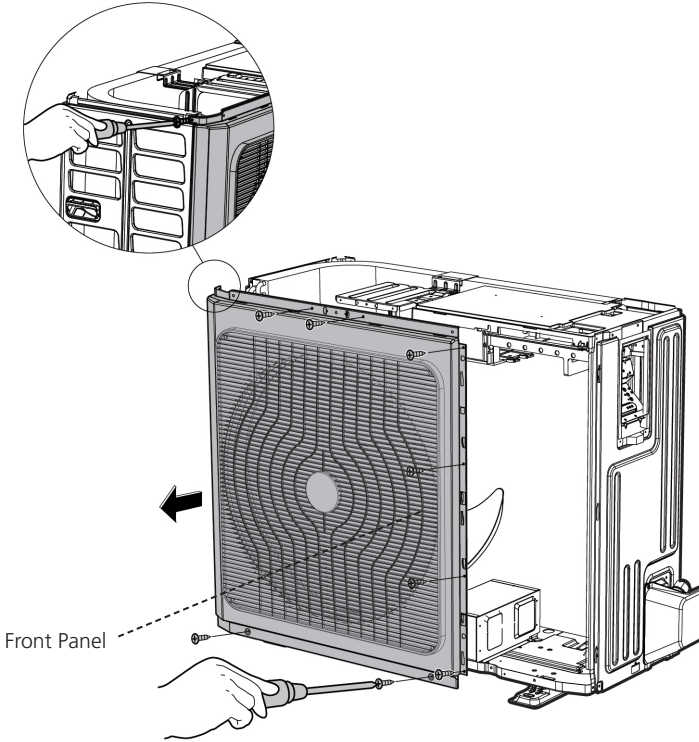
Procedure	Illustration
<p>4) Remove the screws of the front right panel and then remove the front right panel (2 screws) (see CJ_D30_INV_003).</p>	 <p style="text-align: center;">Front Right Panel</p> <p style="text-align: center;">CJ_D30_INV_003</p>
<p>5) Remove the screws of the front panel and then remove the front panel (9 screws) (see CJ_D30_INV_004).</p>	 <p style="text-align: center;">Front Panel</p> <p style="text-align: center;">CJ_D30_INV_004</p>

Note: This section is for reference only. Actual unit appearance may vary.

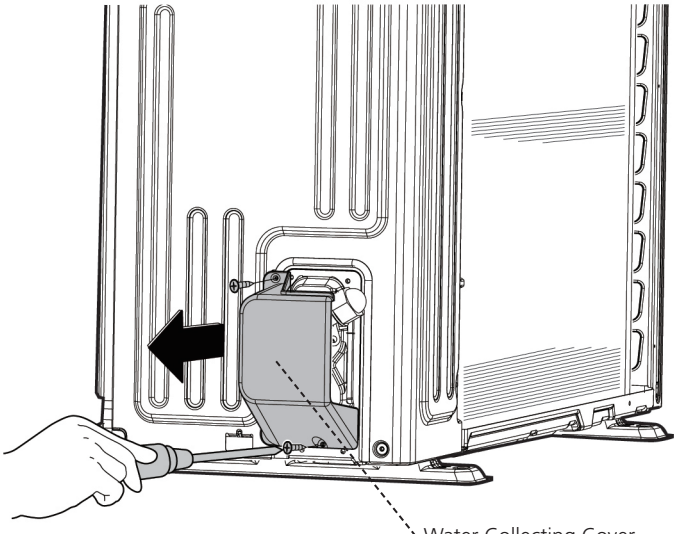
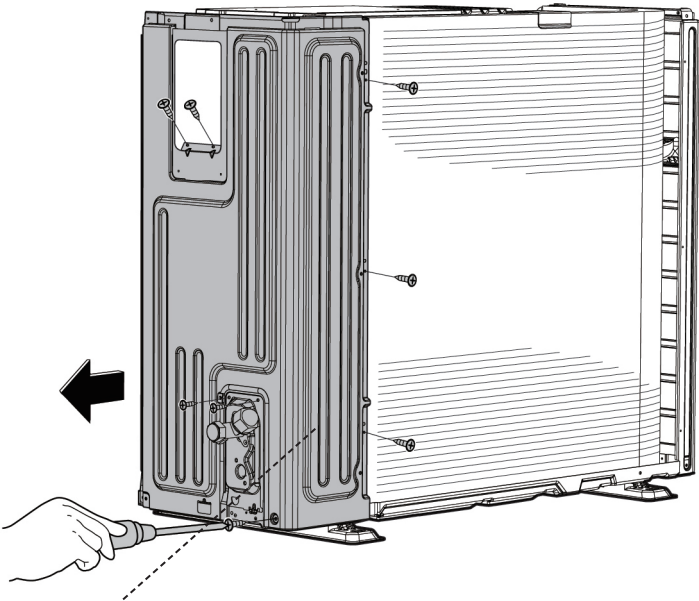
Procedure	Illustration
<p>6) Remove the screws of water collecting cover and then remove the water collecting cover (2 screw) (see CJ_D30_INV_005).</p>	 <p style="text-align: center;">CJ_D30_INV_005</p>
<p>7) Remove the screws of the right panel and then remove the right panel (8 screws) (see CJ_D30_INV_006).</p>	 <p style="text-align: center;">CJ_D30_INV_006</p>

Note: This section is for reference only. Actual unit appearance may vary.

2. Fan disassembly (Antistatic gloves must be worn when you disassemble the electronic box.)

Note: Remove the panel plate and (refer to 1. Panel plate) before disassembling fan.

**MOBA30-09CFN1-BP0W,MOBA30-12CFN1-BP0W,MOBA30-09CFN1-MP0W,MOBA30-12CFN1-MP0W,
MOBA30-09HDN1-BQ0W,MOBA30-12HDN1-BQ0W,MOBA30-09HDN1-MQ0W,MOBA30-12HDN1-MQ0W:**

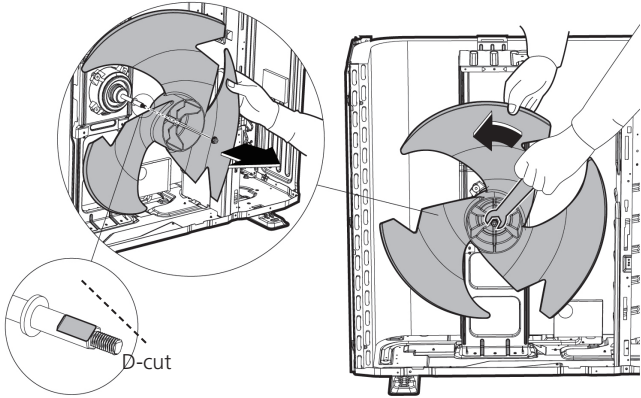
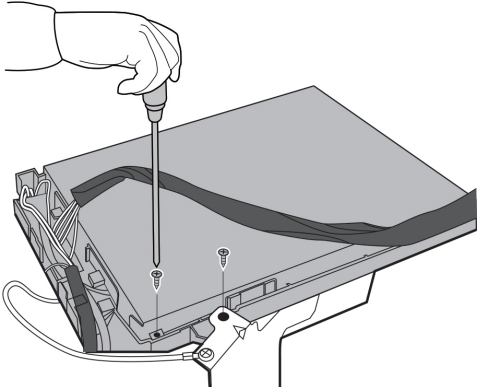
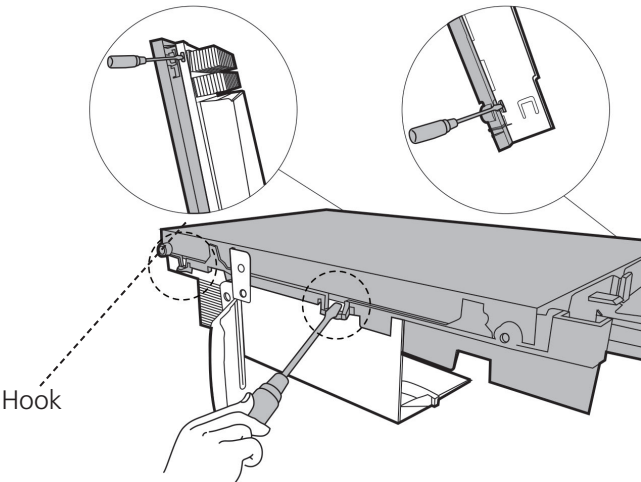
Procedure	Illustration
<p>1) Remove the nut securing the fan with a spanner (see CJ_ODU_INV_001).</p> <p>2) Remove the fan.</p>	 <p style="text-align: center;">CJ_ODU_INV_001</p>
<p>3) Remove the screws of the top cover. (2 screws) (see CJ_ODU_INV_002).</p>	 <p style="text-align: center;">CJ_ODU_INV_002</p>
<p>4) Unfix the hooks and then open the electronic control box cover (4 hooks) (see CJ_ODU_INV_003).</p>	 <p style="text-align: center;">CJ_ODU_INV_003</p>

Note: This section is for reference only. Actual unit appearance may vary.

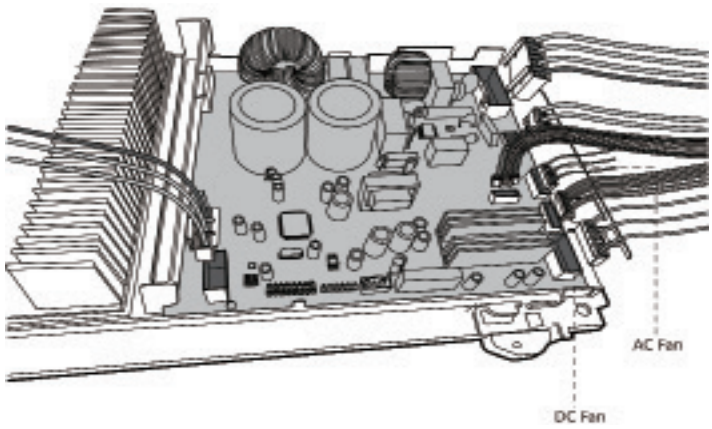
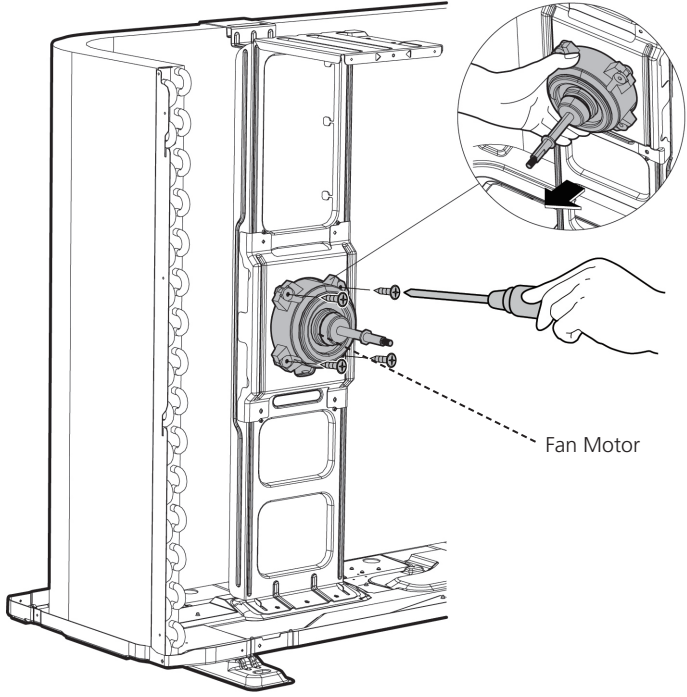
Procedure	Illustration
<p>5) Disconnect the connector for fan motor from the electronic control board (see CJ_ODU_INV_004).</p>	 <p style="text-align: center;">CJ_ODU_INV_004</p>
<p>6) Remove the fixing screws of the fan motor (4 screws) (see CJ_ODU_INV_005).</p> <p>7) Remove the fan motor.</p>	 <p style="text-align: center;">CJ_ODU_INV_005</p>

Note: This section is for reference only. Actual unit appearance may vary.

MOB30-18HDN1-MQ0W, MOCA30-23HDN1-MQ0W;

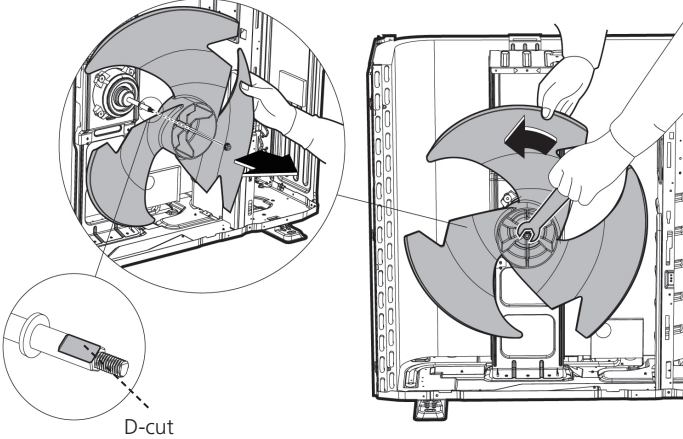
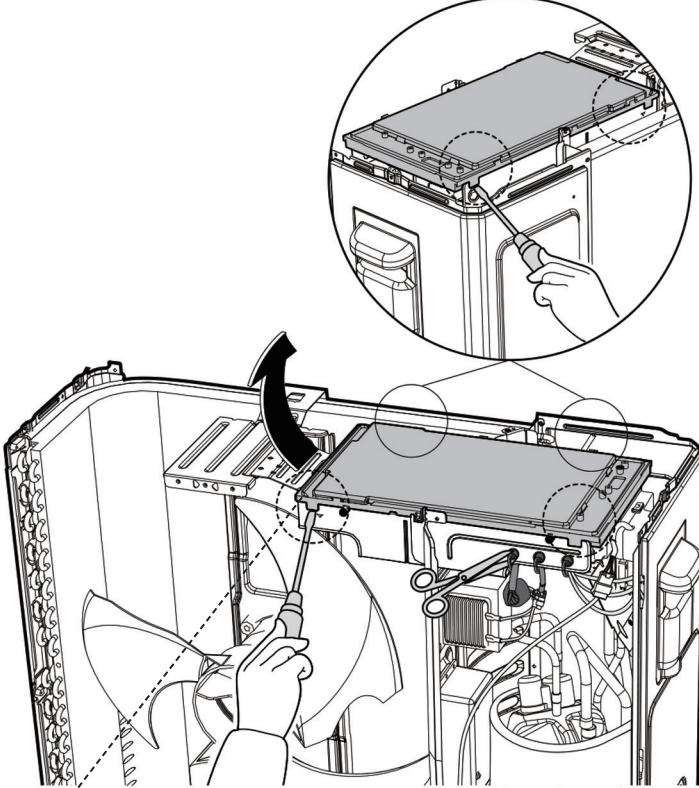
Procedure	Illustration
<p>1) Remove the nut securing the fan with a spanner (see CJ_ODU_INV_006).</p> <p>2) Remove the fan.</p>	 <p style="text-align: center;">CJ_ODU_INV_006</p>
<p>3) Unfix the hooks and then open the electronic control box cover (4 hooks) (see CJ_ODU_INV_007).</p>	 <p style="text-align: center;">CJ_ODU_INV_007</p>

Note: This section is for reference only. Actual unit appearance may vary.

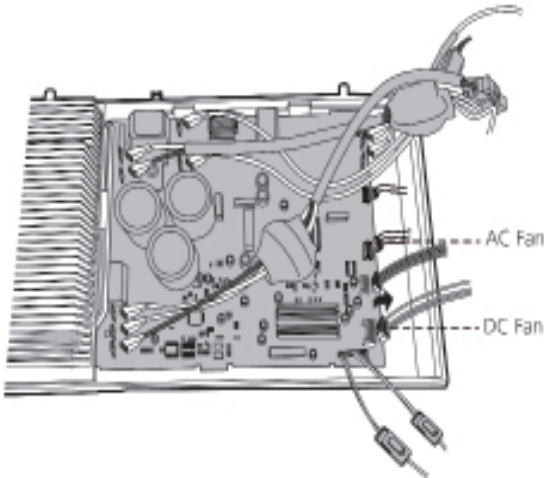
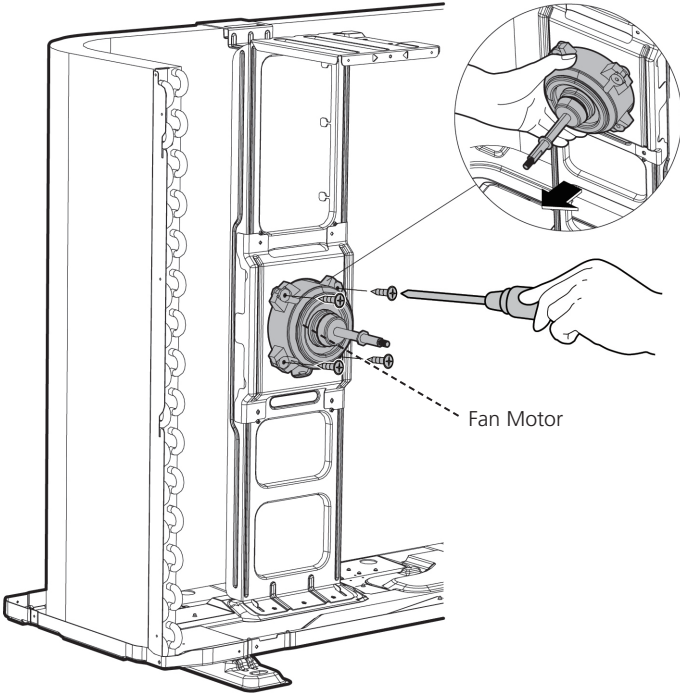
Procedure	Illustration
<p>4) Disconnect the connector for fan motor from the electronic control board (see CJ_ODU_INV_008).</p>	 <p>The diagram shows the internal electronic control board with various components. Two fans are indicated: an AC Fan and a DC Fan. The DC Fan connector is shown being disconnected from the board.</p> <p style="text-align: center;">CJ_ODU_INV_008</p>
<p>5) Remove the fixing screws of the fan motor (4 screws) (see CJ_ODU_INV_009).</p> <p>6) Remove the fan motor.</p>	 <p>The diagram shows a hand using a screwdriver to remove screws from the fan motor. An inset shows a close-up of the fan motor being removed from its mounting. The fan motor is labeled.</p> <p style="text-align: center;">CJ_ODU_INV_009</p>

Note: This section is for reference only. Actual unit appearance may vary.

MOD30-30HFN1-MR0W, MOD30-36HFN1-MP0W:

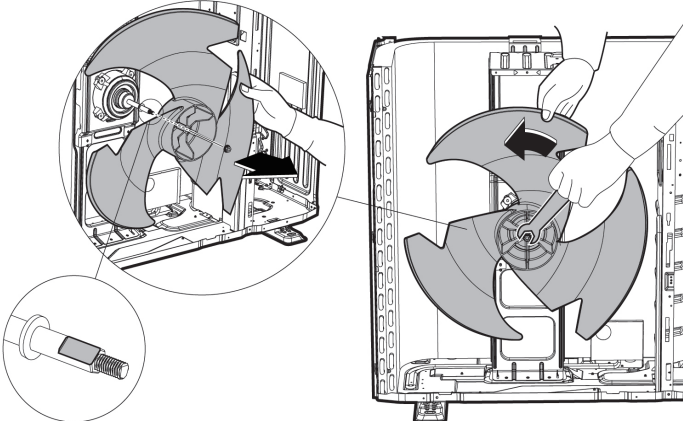
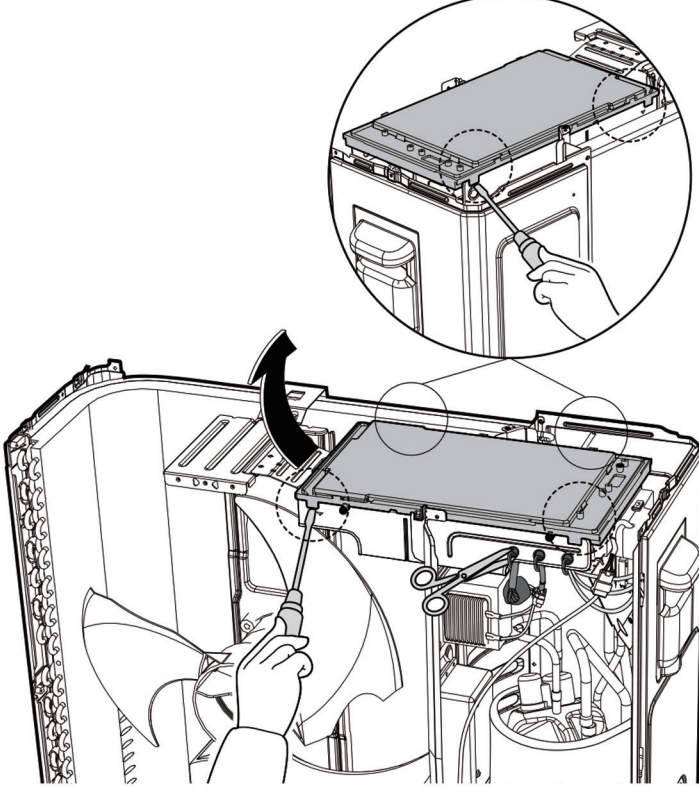
Procedure	Illustration
<p>1) Remove the nut securing the fan with a spanner (see CJ_ODU_INV_010).</p> <p>2) Remove the fan.</p>	 <p style="text-align: center;">CJ_ODU_INV_010</p>
<p>3) Unfix the hooks and then open the electronic control box cover (4 hooks) (see CJ_ODU_INV_011).</p>	 <p style="text-align: center;">CJ_ODU_INV_011</p>

Note: This section is for reference only. Actual unit appearance may vary.

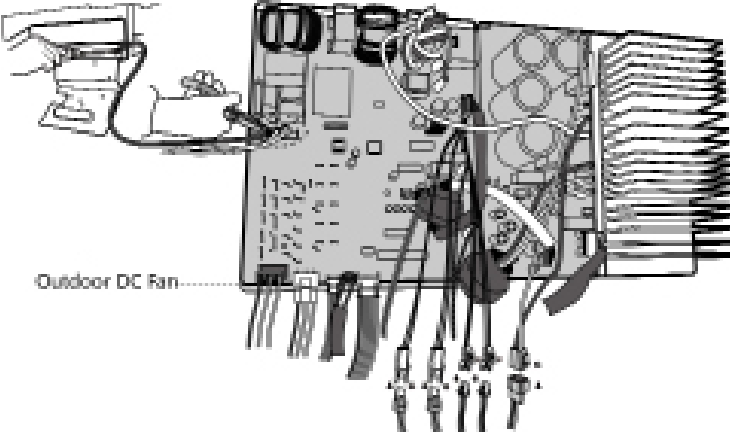
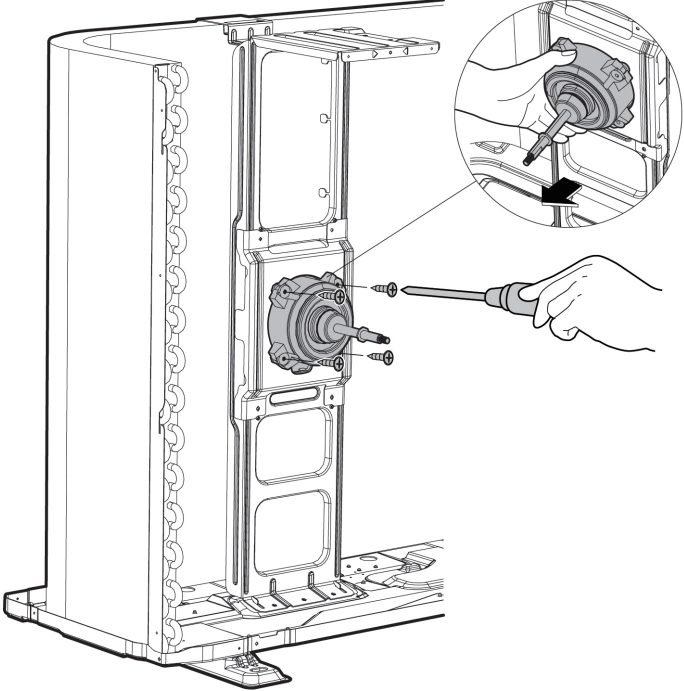
Procedure	Illustration
<p>4) Disconnect the connector for outdoor DC fan from the electronic control board (see CJ_ODU_INV_012).</p>	 <p>CJ_ODU_INV_012</p>
<p>5) Remove the fixing screws of the fan motor (4 screws) (see CJ_ODU_INV_013).</p> <p>6) Remove the fan motor.</p>	 <p>CJ_ODU_INV_013</p>

Note: This section is for reference only. Actual unit appearance may vary.

MOCA30-23CFN1-MP0W, MOB30-17CFN1-MQ0W:

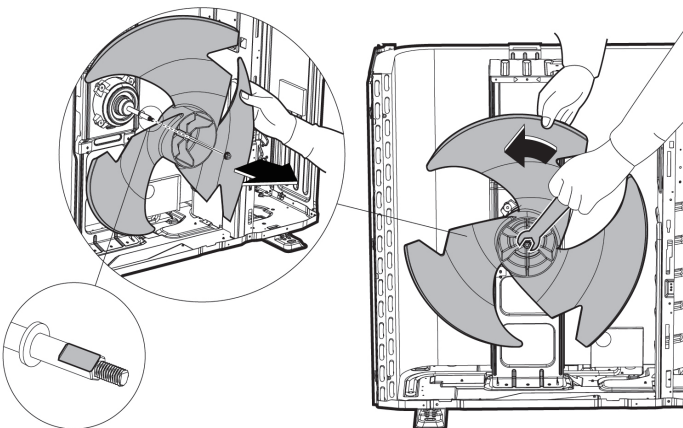
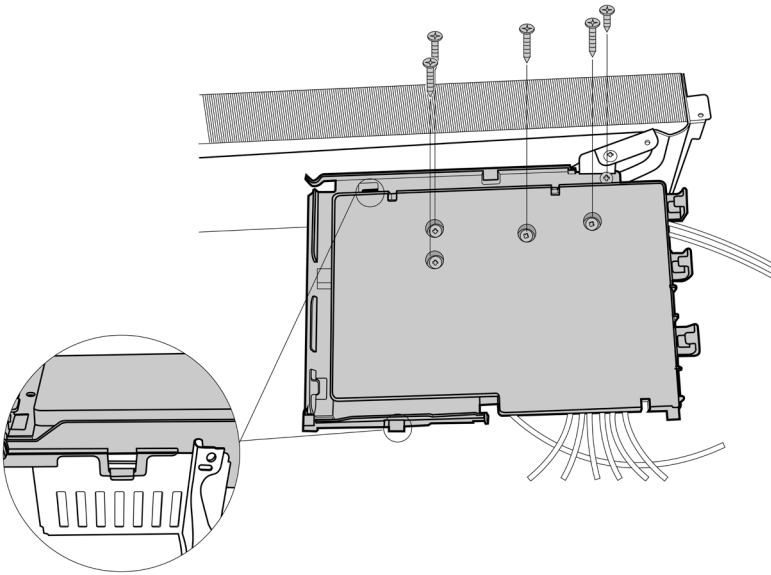
Procedure	Illustration
<p>1) Remove the nut securing the fan with a spanner (see CJ_ODU_INV_006).</p> <p>2) Remove the fan.</p>	 <p>The illustration shows a hand using a spanner to remove a nut from the fan assembly. A separate circular inset shows the removed nut. Another view shows the fan being lifted out of the chassis.</p> <p style="text-align: center;">CJ_ODU_INV_006</p>
<p>3) Unfix the hooks and then open the electronic control box cover (4 hooks) (see CJ_ODU_INV_007).</p>	 <p>The illustration shows the electronic control box cover being lifted away from the chassis. Four screws are shown being removed from the top of the cover. A circular inset shows a close-up of the cover's edge and the chassis it fits into.</p> <p style="text-align: center;">CJ_ODU_INV_007</p>

Note: This section is for reference only. Actual unit appearance may vary.

Procedure

- 4) Disconnect the connector for fan motor from the electronic control board (see CJ_ODU_INV_008).

Illustration

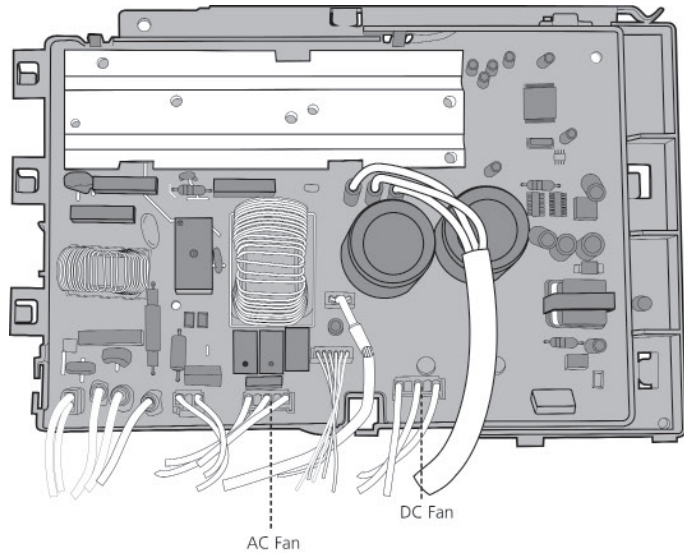

CJ_ODU_INV_008

- 5) Remove the fixing screws of the fan motor (4 screws) (see CJ_ODU_INV_009).
- 6) Remove the fan motor.

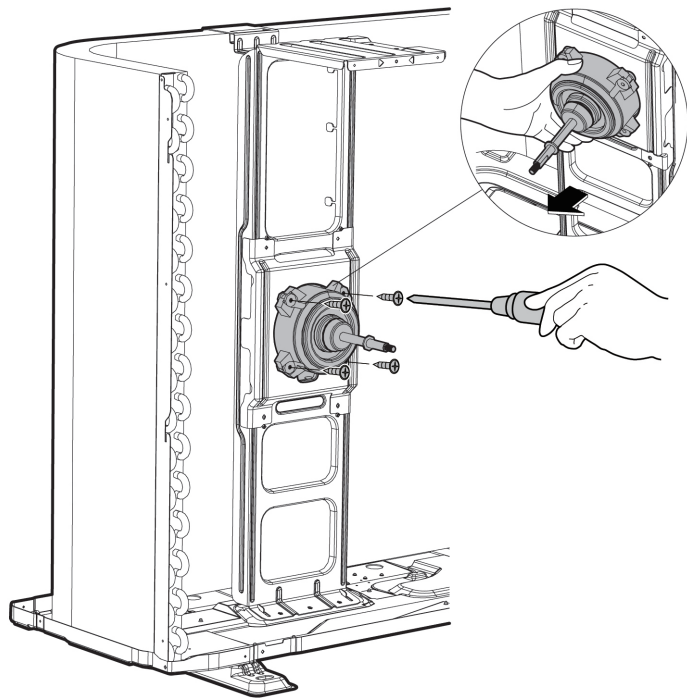

CJ_ODU_INV_009

Note: This section is for reference only. Actual unit appearance may vary.

3. Electrical parts (Antistatic gloves must be worn.)

Note: Remove the panel plate and fan assembly (refer to 1. Panel plate and 2. Fan assembly) before disassembling electrical parts.

MOBA30-09CFN1-BP0W,MOBA30-12CFN1-BP0W,MOBA30-09CFN1-MP0W,MOBA30-12CFN1-MP0W,
MOBA30-09HDN1-BQ0W,MOBA30-12HDN1-BQ0W,MOBA30-09HDN1-MQ0W,MOBA30-12HDN1-MQ0W:

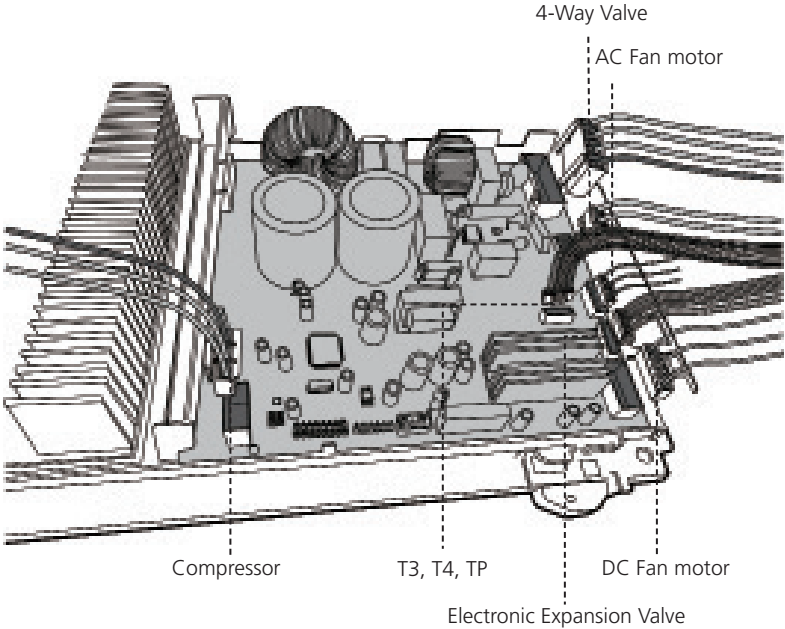
Procedure	Illustration
<ol style="list-style-type: none"> 1) Remove the connector for the compressor (see CJ_ODU_INV_014). 2) Pull out the two blue wires connected with the four way valve (CJ_ODU_INV_014). 3) Pull out connectors of the condenser coil temp. sensor(T3),outdoor ambient temp. sensor(T4) and discharge temp. sensor(TP) (CJ_ODU_INV_014). 4) Disconnect the electronic expansion valve wire (CJ_ODU_INV_014). 5) Then remove the electronic control box (see CJ_ODU_INV_014). 	 <p style="text-align: center;">CJ_ODU_INV_014</p>

Note: This section is for reference only. Actual unit appearance may vary.

MOB30-18HDN1-MQ0W, MOCA30-23HDN1-MQ0W:

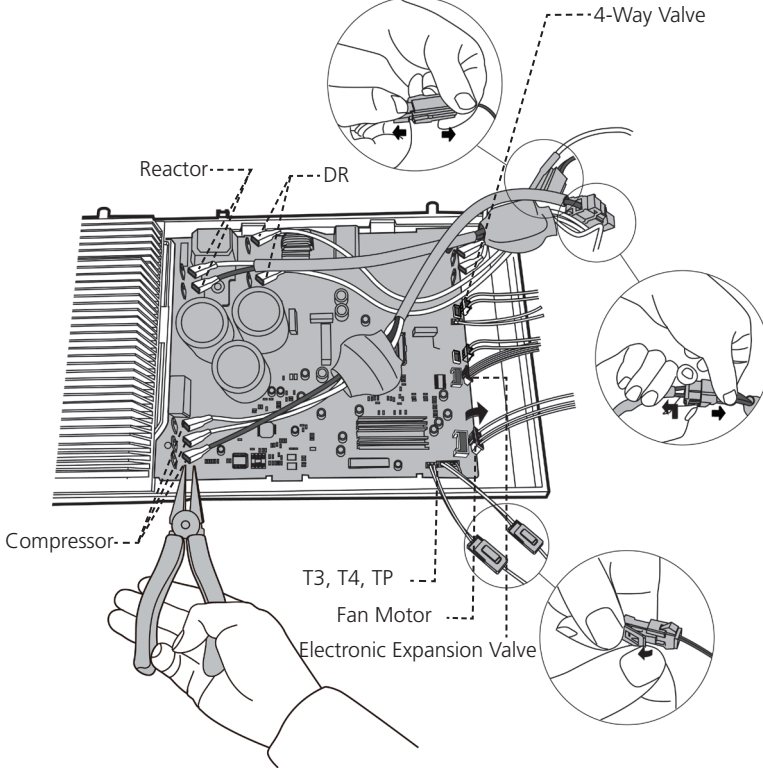
Procedure	Illustration
<ol style="list-style-type: none">1) Remove the connector for the compressor (see CJ_ODU_INV_015).2) Pull out the two blue wires connected with the four way valve (see CJ_ODU_INV_015).3) Pull out connectors of the condenser coil temp. sensor(T3), outdoor ambient temp. sensor(T4) and discharge temp. sensor(T5) (see CJ_ODU_INV_015).4) Disconnect the electronic expansion valve wire (see Fig CJ_ODU_INV_015).5) Remove the connector for the DR and reactor (see Fig CJ_ODU_INV_015).6) Then remove the electronic control box (see Fig CJ_ODU_INV_015).	 <p style="text-align: center;">CJ_ODU_INV_015</p>

Note: This section is for reference only. Actual unit appearance may vary.

MOD30-30HFN1-MR0W, MOD30-36HFN1-MP0W:

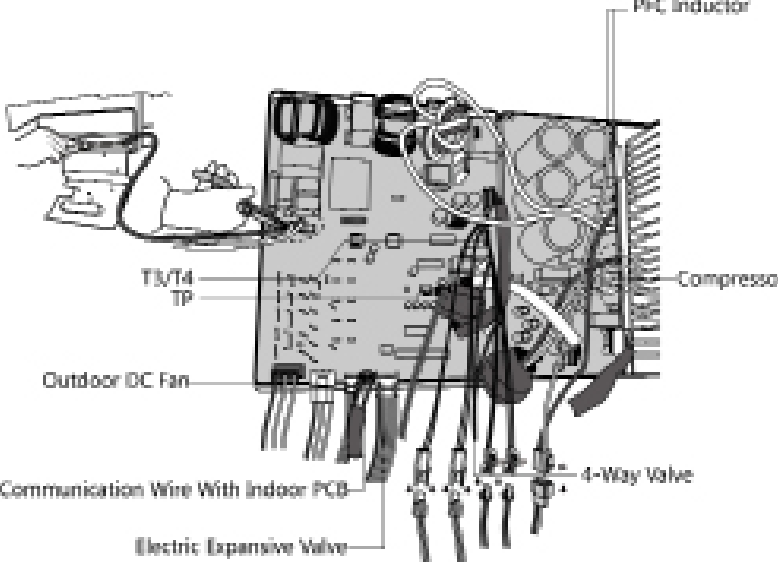
Procedure	Illustration
<ol style="list-style-type: none">1) Remove the connector for the compressor (see CJ_ODU_INV_016).2) Pull out the two blue wires connected with the four way valve (see CJ_ODU_INV_016).3) Pull out connectors of the condenser coil temp. sensor(T3),outdoor ambient temp. sensor(T4) and discharge temp. sensor(TP) (see CJ_ODU_INV_016).4) Disconnect the electronic expansion valve wire (see Fig CJ_ODU_INV_016).5) Disconnect the communication wire indoor PCB (see Fig CJ_ODU_INV_016).6) Disconnect the PFC inductor (see Fig CJ_ODU_INV_016).7) Then remove the electronic control box (see CJ_ODU_INV_016).	 <p style="text-align: center;">CJ_ODU_INV_016</p>

Note: This section is for reference only. Actual unit appearance may vary.

MOCA30-23CFN1-MP0W, MOB30-17CFN1-MQ0W:

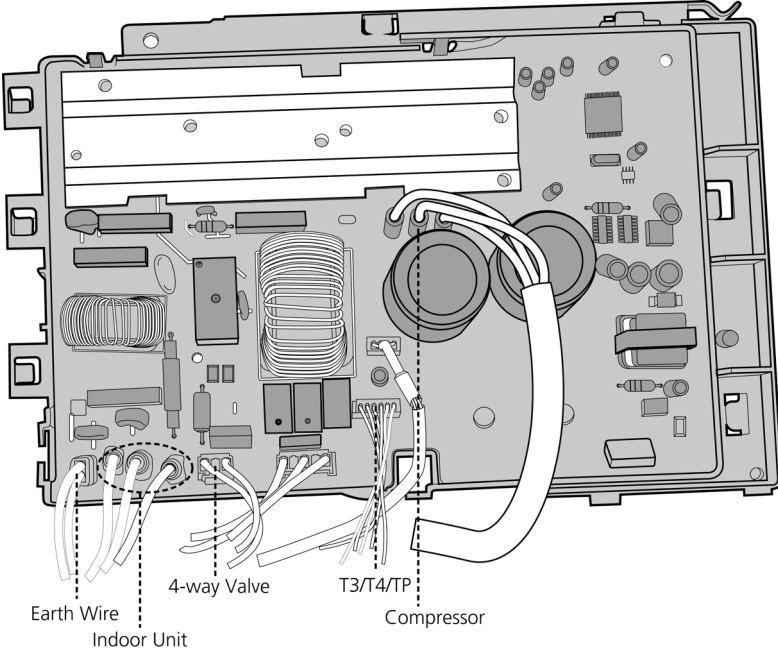
Procedure	Illustration
<ol style="list-style-type: none">1) Remove the connector for the compressor (see CJ_ODU_INV_015).2) Pull out connectors of the condenser coil temp. sensor(T3),outdoor ambient temp. sensor(T4) and discharge temp. sensor(TP) (see CJ_ODU_INV_015).3) Disconnect the 4-way valve wire (see Fig CJ_ODU_INV_015).4) Disconnect the earth wire (see Fig CJ_ODU_INV_015).5) Remove the connector for the indoor unit (see Fig CJ_ODU_INV_015).6) Then remove the electronic control box (see Fig CJ_ODU_INV_015).	 <p style="text-align: center;">CJ_ODU_INV_015</p>

Note: This section is for reference only. Actual unit appearance may vary.

4. Sound blanket

! WARNING: Recover refrigerant from the refrigerant circuit before remove the compressor.

Note: Remove the panel plate, electrical parts, and fan assembly (refer to 1. Panel plate, 2. Electrical parts, and 3. Fan assembly) before disassembling sound blanket.

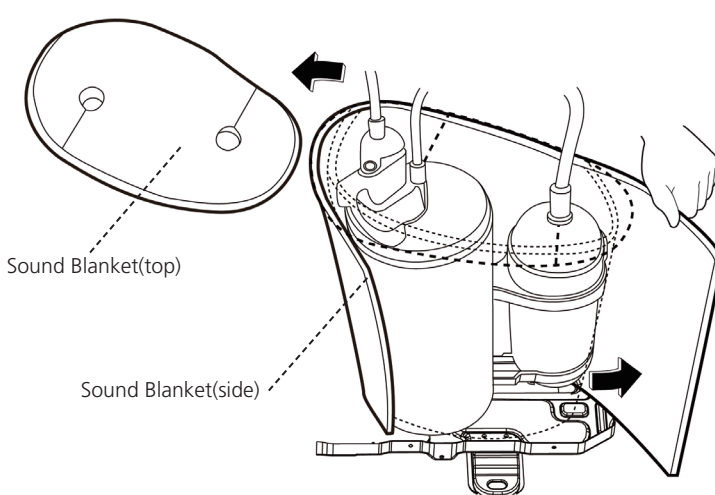
Procedure	Illustration
<p>1) Remove the sound blanket (side and top) (see CJ_ODU_INV_017).</p>	 <p>CJ_ODU_INV_017</p>

Note: This section is for reference only. Actual unit appearance may vary.

5. Four-way valve

⚠ WARNING: Recover refrigerant from the refrigerant circuit before remove the four-way valve.

Note: Remove the panel plate, electrical parts, and fan assembly (refer to 1. Panel plate, 2. Electrical parts, and 3. Fan assembly) before disassembling four-way valve.

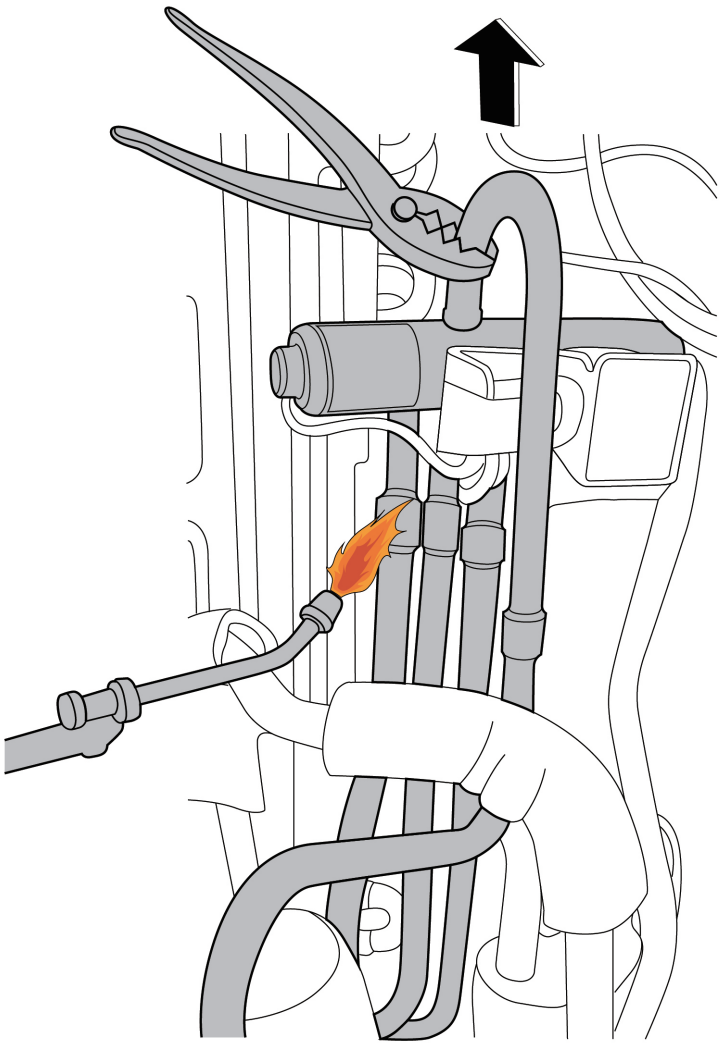
Procedure	Illustration
<ol style="list-style-type: none">1) Heat up the brazed parts and then detach the the four-way valve and the pipe (see CJ_ODU_INV_018).2) Remove the four-way valve assembly with pliers.	 <p data-bbox="925 1646 1157 1691">CJ_ODU_INV_018</p>

Note: This section is for reference only. Actual unit appearance may vary.

6. Compressor

⚠ WARNING: Recover refrigerant from the refrigerant circuit before remove the compressor.

Note: Remove the panel plate, electrical parts, and fan assembly (refer to 1. Panel plate, 2. Electrical parts, and 3. Fan assembly) before disassembling compressor.

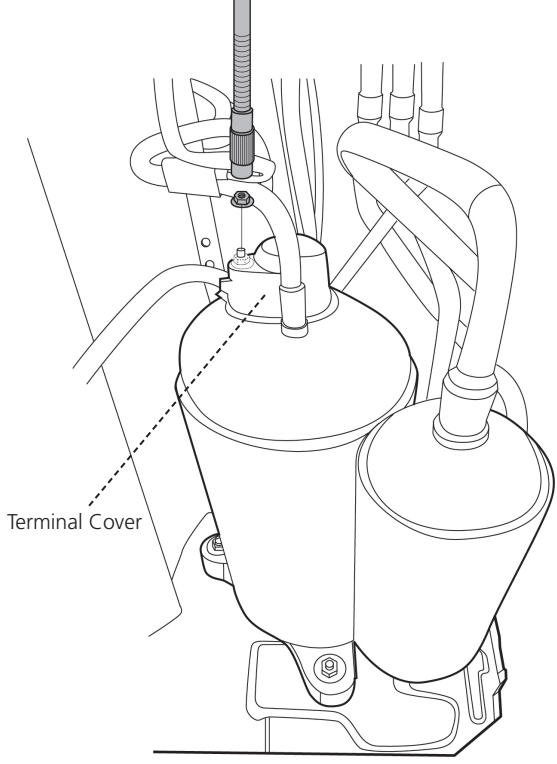
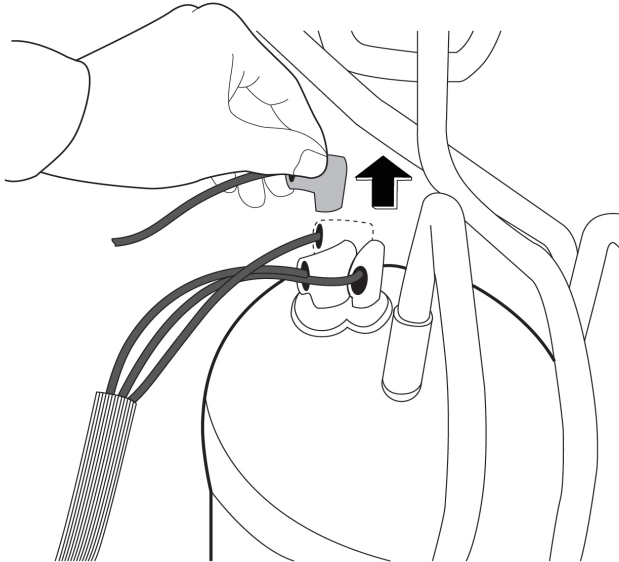
Procedure	Illustration
<p>1) Remove the flange nut of terminal cover and remove the terminal cover (see CJ_ODU_INV_019).</p>	 <p>The diagram shows a top-down view of the compressor unit. A dashed line points to a terminal cover on the left side of the unit. The cover is a cylindrical component with a flange at the top. A hand is shown holding a tool to remove the flange nut. The label 'Terminal Cover' is placed next to the dashed line. Below the diagram is the reference code 'CJ_ODU_INV_019'.</p>
<p>2) Disconnect the connectors (see CJ_ODU_INV_020).</p>	 <p>The diagram shows a close-up view of the electrical connectors on the compressor unit. A hand is shown pulling a connector away from the unit. An upward-pointing arrow indicates the direction of removal. Below the diagram is the reference code 'CJ_ODU_INV_020'.</p>

Note: This section is for reference only. Actual unit appearance may vary.

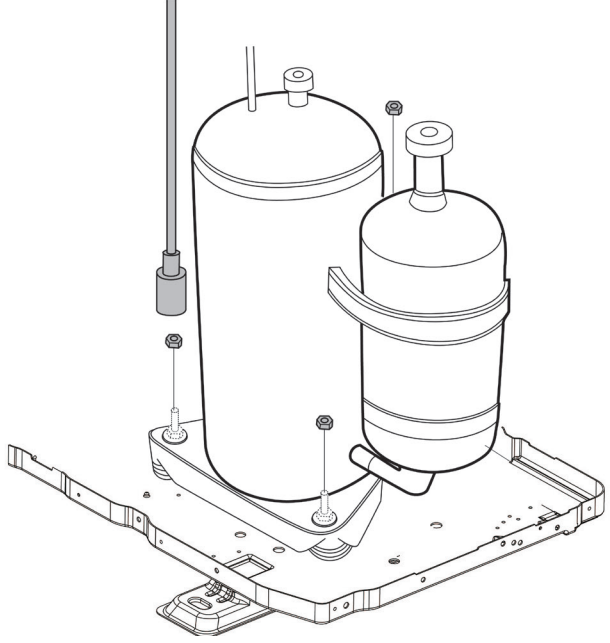
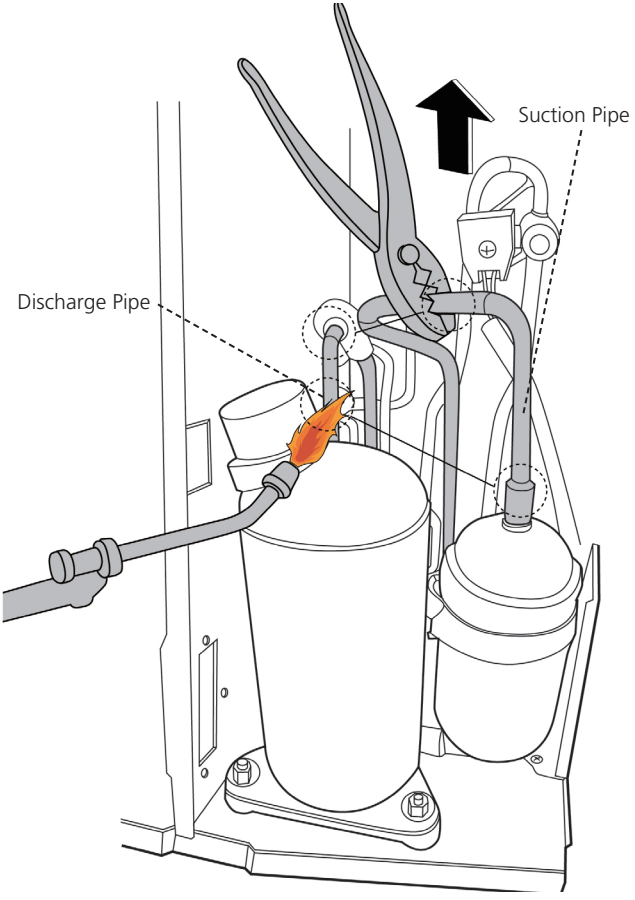
Procedure	Illustration
<p>3) Remove the hex nuts and washers securing the compressor, located on the bottom plate (see CJ_ODU_INV_021).</p>	 <p style="text-align: center;">CJ_ODU_INV_021</p>
<p>4) Heat up the brazed parts and then remove the the discharge pipe and the suction pipe (see CJ_ODU_INV_022).</p> <p>5) Lift the compressor from the base pan assembly with pliers.</p>	 <p style="text-align: center;">CJ_ODU_INV_022</p>

Note: This section is for reference only. Actual unit appearance may vary.

Troubleshooting

Contents

1.	Safety Caution	85
2.	General Troubleshooting	86
3.	Error Diagnosis and Troubleshooting Without Error Code.....	87
	3.1 Remote maintenance.....	87
	3.2 Field maintenance	88
4.	Quick Maintenance by Error Code.....	89
5.	Troubleshooting by Error Code.....	94
	5.1 Common Check Procedures.....	94
	5.2 E0/F4 (EEPROM parameter error)	96
	5.3 E1 (Indoor and outdoor unit communication error)	97
	5.4 E2 (Zero-crossing signal detection error).....	99
	5.5 E3/F5 (Fan speed is operating outside of the normal range)	100
	5.6 E4/E5/F1/F2/F3 (Open circuit or short circuit of temperature sensor diagnosis and solution).....	102
	5.7 EC (Refrigerant Leakage Detection diagnosis and solution)	103
	5.8 F0(Overload current protection diagnosis and solution).....	104
	5.9 P0(IPM malfunction or IGBT over-strong current protection diagnosis and solution)	105

Troubleshooting

Contents

5.10	P1(Over voltage or too low voltage protection diagnosis and solution).....	107
5.11	P2(High temperature protection of IPM module diagnosis and solution).....	108
5.12	P4(Inverter compressor drive error diagnosis and solution)	109
5.13	P6(Low pressure protection diagnosis and solution)	111

1. Safety Caution

⚠ WARNING

Be sure to turn off all power supplies or disconnect all wires to avoid electric shock. While checking indoor/outdoor PCB, please equip oneself with antistatic gloves or wrist strap to avoid damage to the board.

⚠ WARNING

Electricity remains in capacitors even when the power supply is off. Ensure the capacitors are fully discharged before troubleshooting.

Test the voltage between P and N on back of the main PCB with multimeter. If the voltage is lower than 36V, the capacitors are fully discharged.

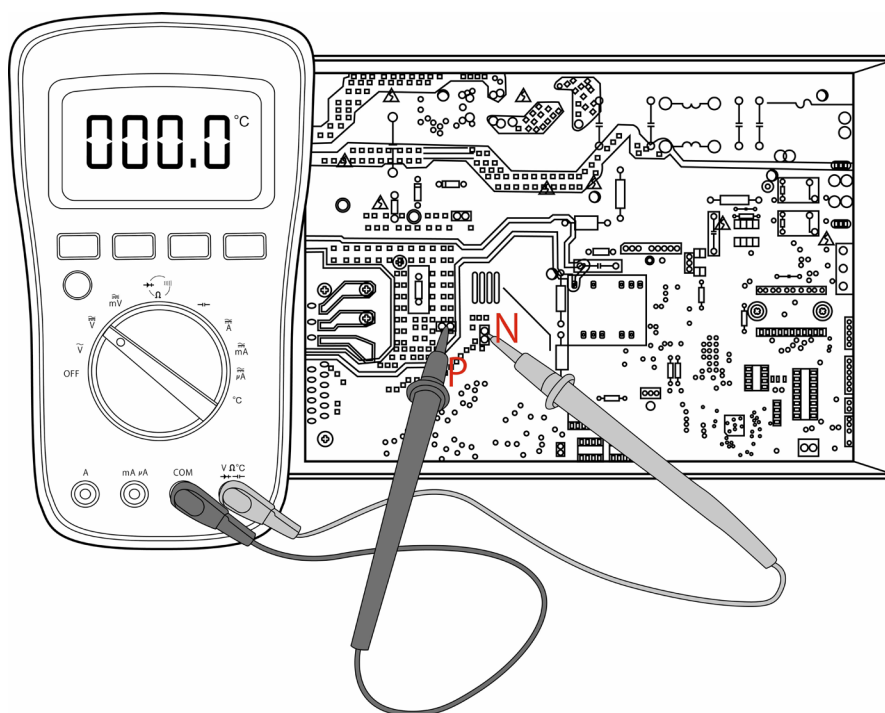

Note: This picture is for reference only. Actual appearance may vary.

2. General Troubleshooting

2.1 Error Display (Indoor Unit)

When the indoor unit encounters a recognized error, the indicator light will flash in a corresponding series, the timer display may turn on or begin flashing, and an error code will be displayed. These error codes are described in the following table:

Operation Lamp	Timer Lamp	Display	Error Information	Solution
1 times	OFF	E0	Indoor unit EEPROM parameter error	Page 84
2 times	OFF	E1	Indoor / outdoor units communication error	Page 85
3 times	OFF	E2	Zero-crossing signal detection error	Page 87
4 times	OFF	E3	The indoor fan speed is operating outside of the normal range	Page 88
5 times	OFF	E4	Indoor room temperature sensor T1 is in open circuit or has short circuited	Page 90
6 times	OFF	E5	Evaporator coil temperature sensor T2 is in open circuit or has short circuited	Page 90
7 times	OFF	EC	Refrigerant leak detected	Page 91
1 times	ON	F0	Overload current protection	Page 92
2 times	ON	F1	Outdoor ambient temperature sensor T4 open circuit or short circuit	Page 90
3 times	ON	F2	Condenser coil temperature sensor T3 is in open circuit or has short circuited	Page 90
4 times	ON	F3	Compressor discharge temperature sensor TP open circuit or short circuit	Page 90
5 times	ON	F4	Outdoor unit EEPROM parameter error	Page 84
6 times	ON	F5	The outdoor fan speed is operating outside of the normal range	Page 88
1 times	FLASH	P0	IPM malfunction or IGBT over-strong current protection	Page 93
2 times	FLASH	P1	Over voltage or over low voltage protection	Page 95
3 times	FLASH	P2	High temperature protection of IPM module	Page 96
4 times	FLASH	P3 ^A	Outdoor ambient temperature too low.	Page --
5 times	FLASH	P4	Inverter compressor drive error	Page 97
7 times	FLASH	P6	Low pressure protection(Only for 36K models)	Page 99

*P3

- 1) In heating mode, when the outdoor temperature is lower than -25 °C for 1 hour, the indoor unit display error code P3.
- 2) If the outdoor temperature is higher than -22 °C for 10 minutes and compressor stop for 1 hour or outdoor temperature is higher than -5 °C for 10 minutes, then the unit will return to work

For other errors:

The display board may show a garbled code or a code undefined by the service manual. Ensure that this code is not a temperature reading.

Troubleshooting:

Test the unit using the remote control. If the unit does not respond to the remote, the indoor PCB requires replacement. If the unit responds, the display board requires replacement.

3. Error Diagnosis and Troubleshooting Without Error Code

WARNING

Be sure to turn off unit before any maintenance to prevent damage or injury.

3.1 Remote maintenance

SUGGESTION: When troubles occur, please check the following points with customers before field maintenance.

NO.	Problem	Solution
1	Unit will not start	Page 78-79
2	The power switch is on but fans will not start	Page 78-79
3	The temperature on the display cannot be set	Page 78-79
4	Unit is on but the wind is not cold(hot)	Page 78-79
5	Unit runs, but shortly stops	Page 78-79
6	The unit startup and stop frequently	Page 78-79
7	Unit runs continuously but insufficient cooling(heating)	Page 78-79
8	Cool can not change to heat	Page 78-79
9	Unit is noisy	Page 78-79

3.2 Field maintenance

NO.	Problem	Solution
1	Unit will not start	Page 80-81
2	Compressor will not start but fans run	Page 80-81
3	Compressor and condenser (outdoor) fan will not start	Page 80-81
4	Evaporator (indoor) fan will not start	Page 80-81
5	Condenser (Outdoor) fan will not start	Page 80-81
6	Unit runs, but shortly stops	Page 80-81
7	Compressor short-cycles due to overload	Page 80-81
8	High discharge pressure	Page 80-81
9	Low discharge pressure	Page 80-81
10	High suction pressure	Page 80-81
11	Low suction pressure	Page 80-81
12	Unit runs continuously but insufficient cooling	Page 80-81
13	Too cool	Page 80-81
14	Compressor is noisy	Page 80-81
15	Horizontal louver can not revolve	Page 80-81

4. Quick Maintenance by Error Code

If you do not have the time to test whether specific parts are faulty, you can directly change the required parts according to the error code.

You can find the parts to replace by error code in the following table.

Part requiring replacement	Error Code								
	E0	E1	E2	E3	E4	E5	EC	F0	F1
Indoor PCB	✓	✓	✓	✓	✓	✓	✓	x	x
Outdoor PCB	x	✓	x	x	x	x	x	✓	✓
Reactor	x	✓	x	x	x	x	x	x	x
Indoor fan motor	x	x	x	✓	x	x	x	x	x
Outdoor fan motor	x	x	x	x	x	x	x	x	x
Temperature sensor	x	x	x	x	✓	✓	✓	x	✓
T2 Sensor	x	x	x	x	x	x	✓	x	x
Additional refrigerant	x	x	x	x	x	x	x	x	x
Compressor	x	x	x	x	x	x	x	✓	x
IPM board	x	x	x	x	x	x	x	x	x
Outdoor unit	x	x	x	x	x	x	x	✓	x
Display board	x	x	✓	x	x	x	x	x	✓

Part requiring replacement	Error Code								
	F2	F3	F4	F5	P0	P1	P2	P4	P6
Indoor PCB	x	x	x	x	x	x	x	x	x
Outdoor PCB	✓	✓	✓	✓	✓	✓	✓	✓	✓
Reactor	x	x	x	x	x	✓	x	x	x
Indoor fan motor	x	x	x	x	x	x	x	x	✓
Outdoor fan motor	x	x	x	✓	x	x	x	x	x
Temperature sensor	✓	✓	x	x	x	x	x	x	x
T2 Sensor	x	x	x	x	x	x	x	x	x
Additional refrigerant	x	x	x	x	x	x	x	x	x
Compressor	x	x	x	x	✓	x	x	✓	x
IPM board	x	x	x	x	✓	✓	x	✓	x
Outdoor unit	x	x	x	x	x	x	x	x	x

1.Remote Maintenance		Electrical Circuit					Refrigerant Circuit					
Possible causes of trouble	Power failure											
	The main power tripped											
	Loose connections											
	Faulty transformer											
	The voltage is too high or too low											
	The remote control is powered off											
	Broken remote control											
	Dirty air filter											
	Dirty condenser fins											
	The setting temperature is higher/lower than the room's(cooling/heating)											
The ambient temperature is too high/low when the mode is cooling/heating												
Fan mode												
SILENCE function is activated(optional function)												
Frosting and defrosting frequently												
Unit will not start	☆	☆	☆	☆								
The power switch is on but fans will not start			☆	☆	☆							
The temperature on the display board cannot be set						☆	☆					
Unit is on but the wind is not cold(hot)								☆	☆	☆		
Unit runs, but shortly stops					☆			☆	☆			
The unit startup and stop frequently					☆				☆			☆
Unit runs continuously but insufficient cooling(heating)								☆	☆	☆	☆	
Cool can not change to heat												
Unit is noisy												
Test method / remedy	Test voltage											
	Close the power switch											
	Inspect connections - tighten											
	Change the transformer											
	Test voltage											
	Replace the battery of the remote control											
	Replace the remote control											
	Clean or replace											
	Clean											
	Adjust the setting temperature											
Turn the AC later												
Adjust to cool mode												
Turn off SILENCE function.												
Turn the AC later												

Others	
Check heat load	Heavy load condition
Tighten bolts or screws	Loosen hold down bolts and / or screws
Close all the windows and doors	Bad airproof
Remove the obstacles	The air inlet or outlet of either unit is blocked
Reconnect the power or press ON/OFF button on remote control to restart	Interference from cell phone towers and remote boosters
Remove them	Shipping plates remain attached

2. Field Maintenance		Electrical Circuit													
Possible causes of trouble	Possible causes of trouble														
	Power failure	Blown fuse or varistor	Loose connections	Shorted or broken wires	Safety device opens	Faulty thermostat / room temperature sensor	Wrong setting place of temperature sensor	Faulty transformer	Shorted or open capacitor	Faulty magnetic contactor for compressor	Faulty magnetic contactor for fan	Low voltage	Faulty stepping motor	Shorted or grounded compressor	Shorted or grounded fan motor
Unit will not start	☆	☆	☆	☆	☆			☆							
Compressor will not start but fans run				☆	☆			☆	☆					☆	
Compressor and condenser (outdoor) fan will not start				☆	☆				☆						
Evaporator (indoor) fan will not start				☆				☆		☆					☆
Condenser (Outdoor) fan will not start				☆	☆			☆		☆					☆
Unit runs, but shortly stops									☆		☆				
Compressor short-cycles due to overload									☆		☆				
High discharge pressure															
Low discharge pressure															
High suction pressure															
Low suction pressure															
Unit runs continuously but insufficient cooling															
Too cool					☆	☆									
Compressor is noisy															
Horizontal louver can not revolve			☆	☆									☆		
Test method / remedy	Test method / remedy														
	Test voltage	Inspect fuse type & size	Inspect connections - tighten	Test circuits with tester	Test continuity of safety device	Test continuity of thermostat / sensor & wiring	Place the temperature sensor at the central of the air inlet grille	Check control circuit with tester	Check capacitor with tester	Test continuity of coil & contacts	Test continuity of coil & contacts	Test voltage	Replace the stepping motor	Check resistance with multimeter	Check resistance with multimeter

Refrigerant Circuit										Others
Replace the compressor										Compressor stuck
Leak test	☆									Shortage of refrigerant
Replace restricted part	☆	☆								Restricted liquid line
Clean or replace	☆	☆								Dirty air filter
Clean coil	☆	☆								Dirty evaporator coil
Check fan	☆	☆								Insufficient air through evaporator coil
Change charged refrigerant volume			☆							Overcharge of refrigerant
Clean condenser or remove obstacle	☆									Dirty or partially blocked condenser
Purge, evacuate and recharge	☆	☆								Air or incompressible gas in refrigerant cycle
Remove obstruction to air flow	☆									Short cycling of condensing air
Remove obstruction in air or water flow					☆					High temperature condensing medium
Remove obstruction in air or water flow					☆					Insufficient condensing medium
Replace compressor										Broken compressor internal parts
Test compressor efficiency	☆					☆				Inefficient compressor
Replace valve							☆			Expansion valve obstructed
Replace valve								☆		Expansion valve or capillary tube closed completely
Replace valve								☆		Leaking power element on expansion valve
Fix feeler bulb								☆		Poor installation of feeler bulb
Check heat load							☆			Heavy load condition
Tighten bolts or screws										Loosen hold down bolts and / or screws
Remove them										Shipping plates remain attached
Choose AC of larger capacity or add the number of AC										Poor choices of capacity
Rectify piping so as not to contact each other or with external plate									☆	Contact of piping with other piping or external plate

5. Troubleshooting by Error Code

5.1 Common Check Procedures

5.1.1 Temperature Sensor Check

Disconnect the temperature sensor from PCB, measure the resistance value with a tester.

Temperature Sensors.

Room temp.(T1) sensor,

Indoor coil temp.(T2) sensor,

Outdoor coil temp.(T3) sensor,

Outdoor ambient temp.(T4) sensor,

Compressor discharge temp.(Tp) sensor.

Measure the resistance value of each winding by using the multi-meter.

5.1.2 Compressor checking

Measure the resistance value of each winding by using the tester.

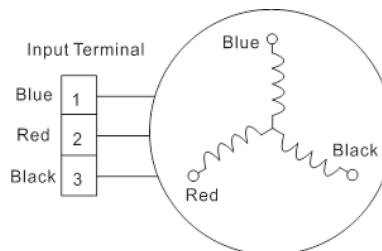

Position	Resistance Value			
Model	ASN98D22UFZ	ASM135D23UFZ	ATF235D22UMT	ATF250D22UMT
Blue - Red	1.57Ω(20°C/68°F)	1.75Ω(20°C/68°F)	0.75Ω(20°C/68°F)	0.75Ω(20°C/68°F)
Blue - Black				
Red - Blue				



5.1.3 IPM Continuity Check

Turn off the power, let the large capacity electrolytic capacitors discharge completely, and dismount the IPM. Use a digital tester to measure the resistance between P and UVWN; UVW and N.

Digital tester		Normal resistance value	Digital tester		Normal resistance value
(+)Red	(-)Black		(+)Red	(-)Black	
P	N	∞ (Several MΩ)	U	N	∞ (Several MΩ)
	U		V		
	V		W		
	W		(+)Red		

5.1.4 Normal voltage of P and N

Normal voltage of P and N			
208-240V(1-phase,3-phase)		380-420V(3-phase)	
In standby			
around 310VDC		around 530VDC	
In operation			
With passive PFC module	With partial active PFC module	With fully active PFC module	/
>200VDC	>310VDC	>370VDC	>450VDC

5.2 E0/F4 (EEPROM parameter error)

Description: Indoor or outdoor PCB main chip does not receive feedback from EEPROM chip.

Recommended parts to prepare:

- Indoor PCB
- Outdoor PCB

Troubleshooting and repair:

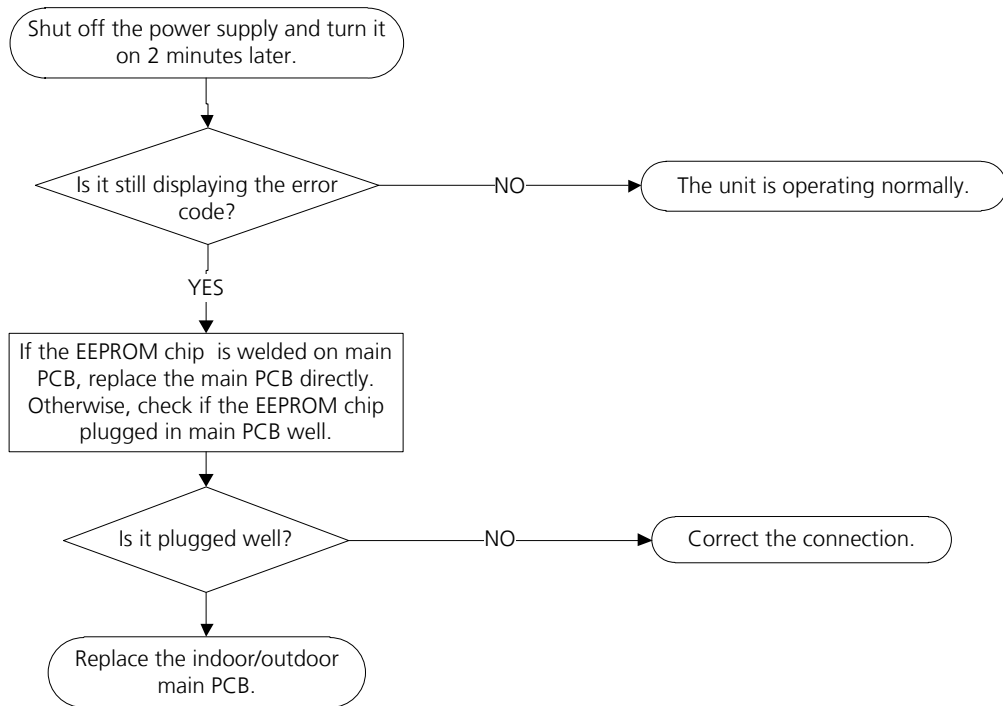

Remarks:

The location of the EEPROM chip on the indoor and outdoor PCB is shown in the following two images:

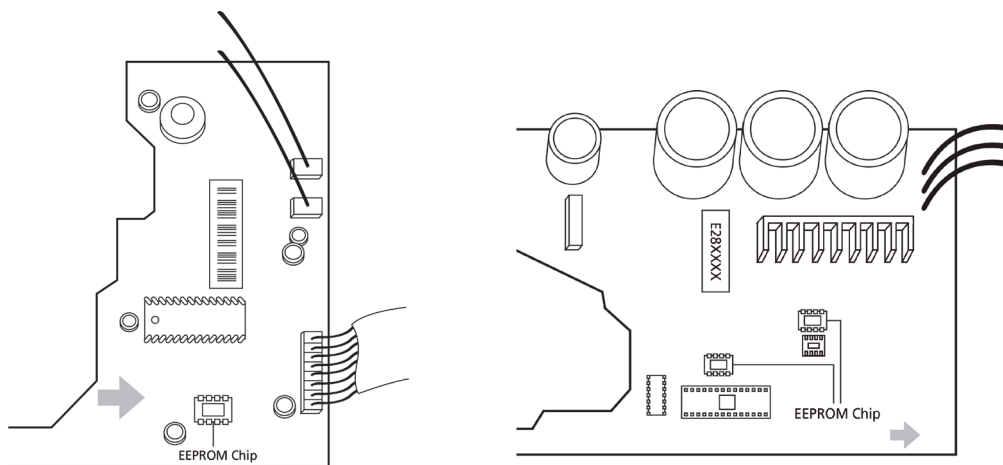

Note: These images are for reference only.

5.3 E1 (Indoor and outdoor unit communication error)

Description: The indoor unit has not received feedback from the outdoor unit for 110 seconds, four consecutive times.

Recommended parts to prepare:

- Indoor PCB
- Outdoor PCB
- Reactor

Troubleshooting and repair:

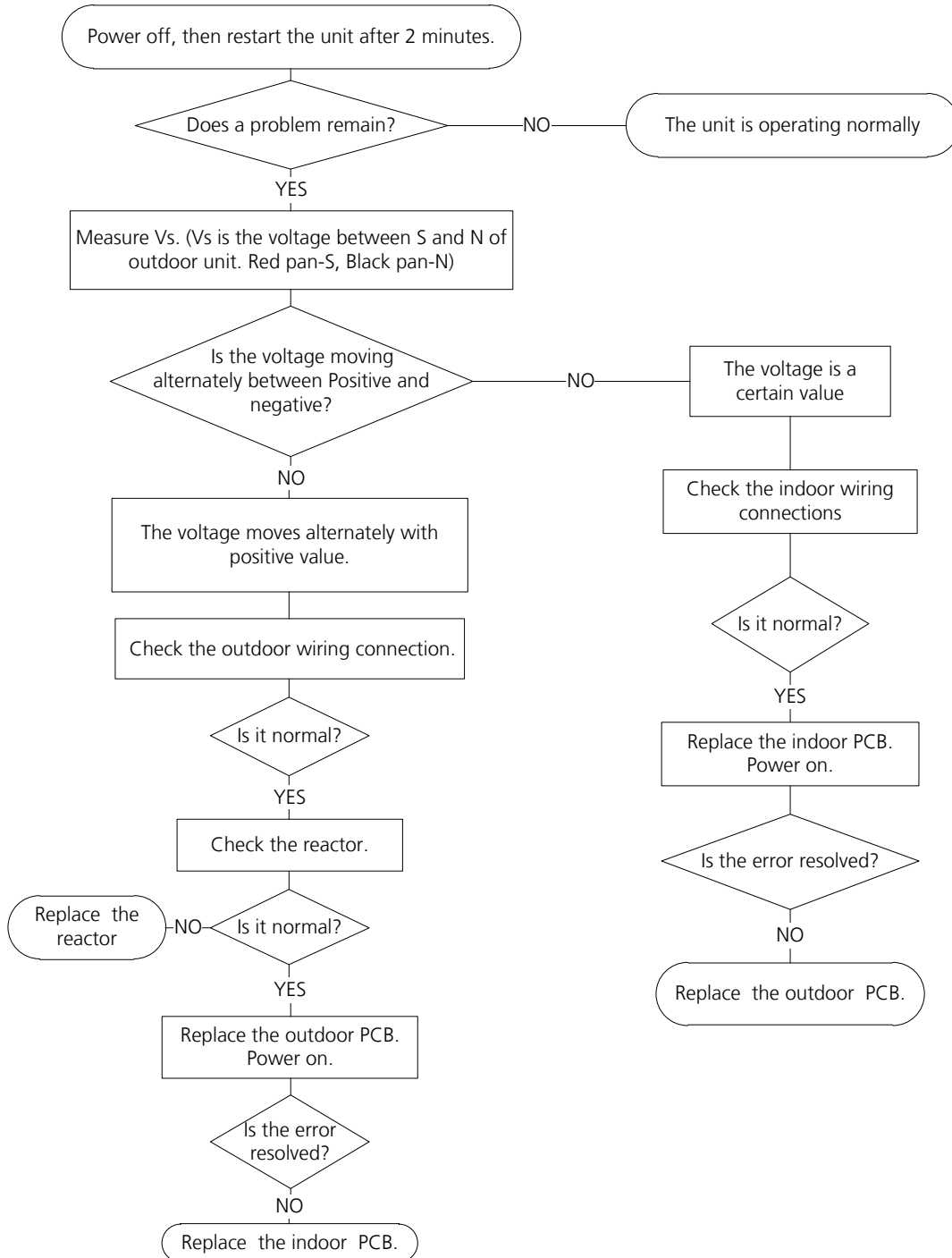

Remarks:

- Use a multimeter to test the DC voltage between 2 port and 3 port of outdoor unit. The red pin of multimeter connects with 2 port while the black pin is for 3 port.
- When AC is normal running, the voltage will move alternately between -25V to 25V.
- If the outdoor unit has malfunction, the voltage will move alternately with positive value.
- While if the indoor unit has malfunction, the voltage will be a certain value.

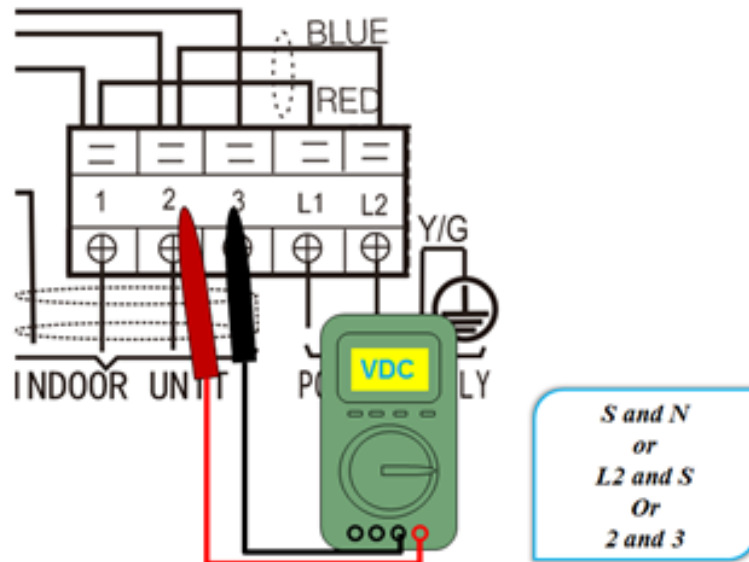

- Use a multimeter to test the resistance of the reactor which does not connect with capacitor.
- The normal value should be around zero ohm. Otherwise, the reactor must have malfunction.



5.4 E2 (Zero crossing detection error diagnosis and solution)

Description: When PCB does not receive zero crossing signal feedback for 4 minutes or the zero crossing signal time interval is abnormal.

Recommended parts to prepare:

- Connection wires
- Indoor PCB

Troubleshooting and repair:

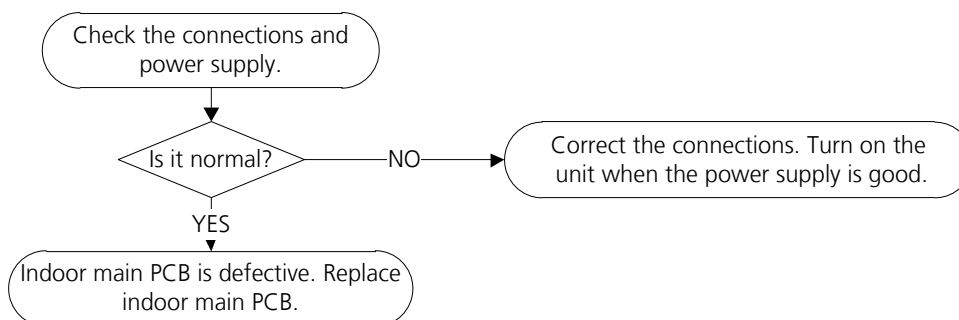

5.5 E3/F5(Fan speed is operating outside of the normal range)

Description: When the indoor fan speed keeps too low (300RPM) for certain time, the unit will stop and the LED will display the failure(E3). When the outdoor fan speed registers below 150RPM or over 1500RPM for an extended period of time, the unit will stop and the LED will display the failure(F5).

Recommended parts to prepare:

- Connection wires
- Fan assembly
- Fan motor
- PCB

Troubleshooting and repair:

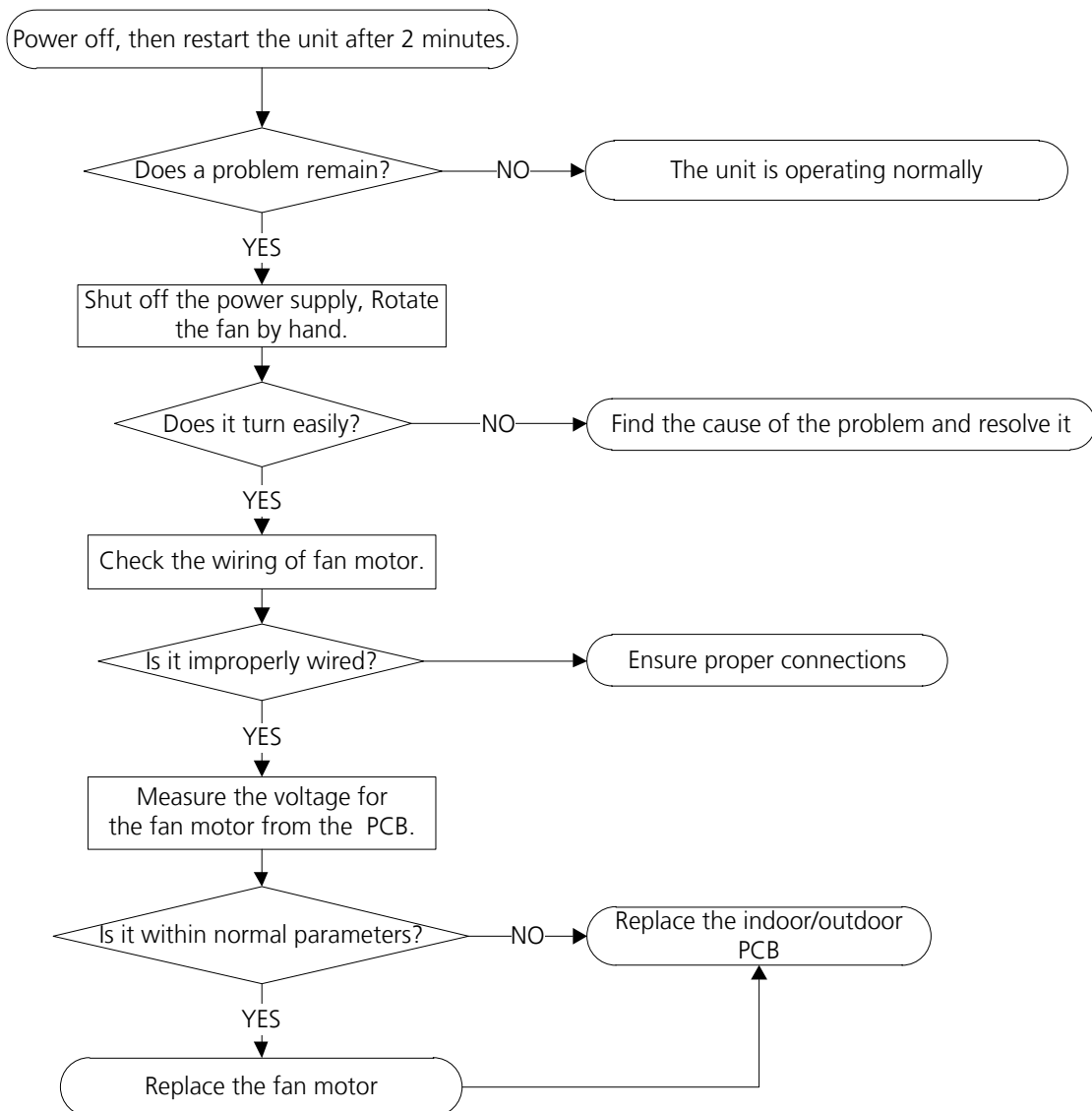

Index:

1. Indoor or Outdoor DC Fan Motor(control chip is in fan motor)

Power on and when the unit is in standby, measure the voltage of pin1-pin3, pin4-pin3 in fan motor connector. If the value of the voltage is not in the range showing in below table, the PCB must has problems and need to be replaced.

- DC motor voltage input and output (voltage: 220-240V~):

No.	Color	Signal	Voltage
1	Red	Vs/Vm	280V~380V
2	---	---	---
3	Black	GND	0V
4	White	Vcc	14-17.5V
5	Yellow	Vsp	0~5.6V
6	Blue	FG	14-17.5V

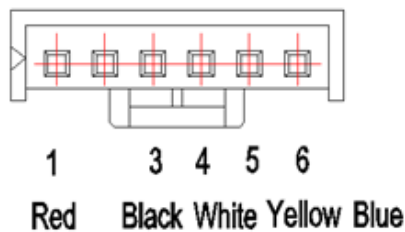

2. Outdoor DC Fan Motor (control chip is in outdoor PCB)

Release the UVW connector. Measure the resistance of U-V, U-W, V-W. If the resistance is not equal to each other, the fan motor must has problems and need to be replaced. otherwise the PCB must has problems and need to be replaced.

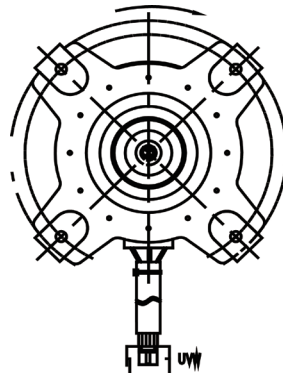

3. Indoor AC Fan Motor

Power on and set the unit running in fan mode at high fan speed. After running for 15 seconds, measure the voltage of pin1 and pin2. If the value of the voltage is less than 100V(208~240V power supply) or 50V(115V power supply), the PCB must has problems and need to be replaced.

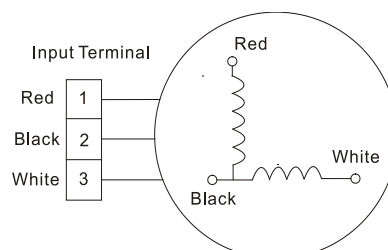

5.6 E4/E5/F1/F2/F3 (Open circuit or short circuit of temperature sensor diagnosis and solution)

Description: If the sampling voltage is lower than 0.06V or higher than 4.94V, the LED will display the failure.

Recommended parts to prepare:

- Connection wires
- Sensors
- PCB

Troubleshooting and repair:

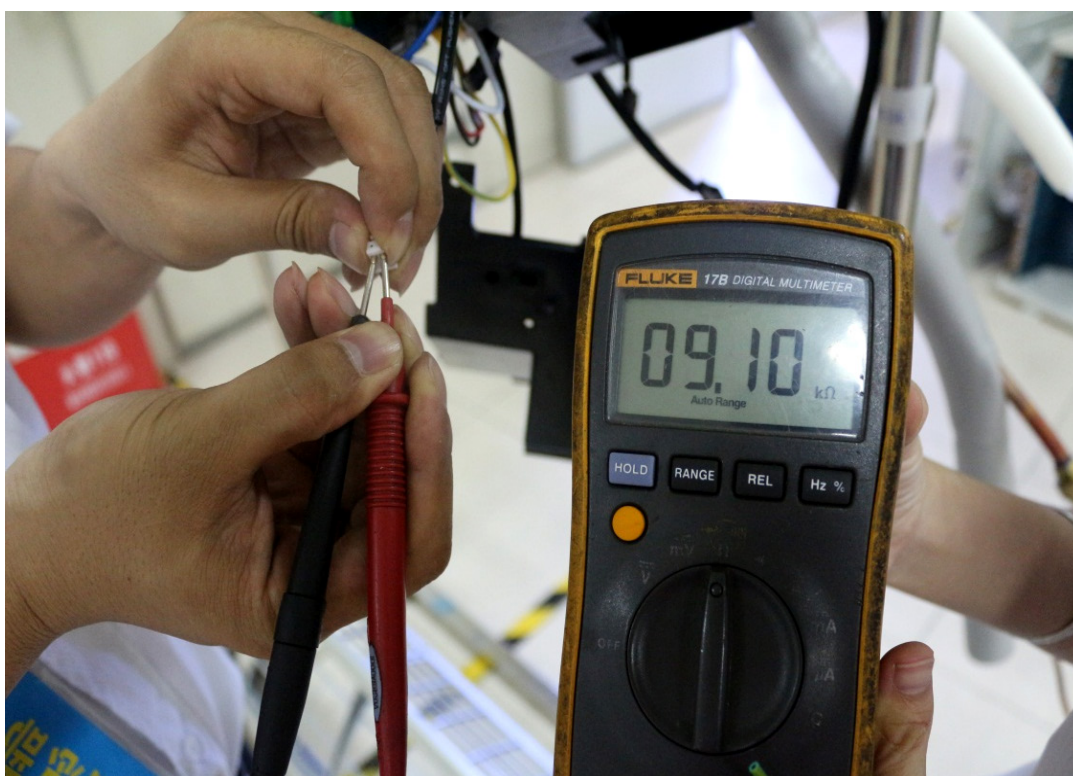
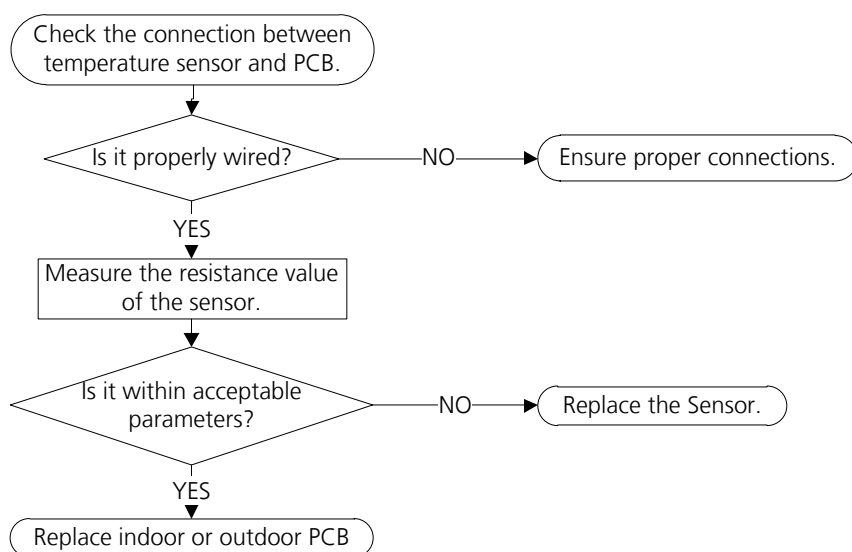

5.7 EC (Refrigerant Leakage Detection diagnosis and solution)

Description: Define the evaporator coil temp.T2 of the compressor just starts running as Tcool.

In the beginning 8 minutes after the compressor starts up, if $T2 < T_{cool} - 2^{\circ}\text{C}$ does not keep continuous 4 seconds and compressor running frequency higher than 50Hz does not keep continuous 3 minutes, and this situation happens 3 times, the display area will show "EC" and AC will turn off.

Recommended parts to prepare:

- T2 sensor
- Indoor PCB
- Additional refrigerant

Troubleshooting and repair:

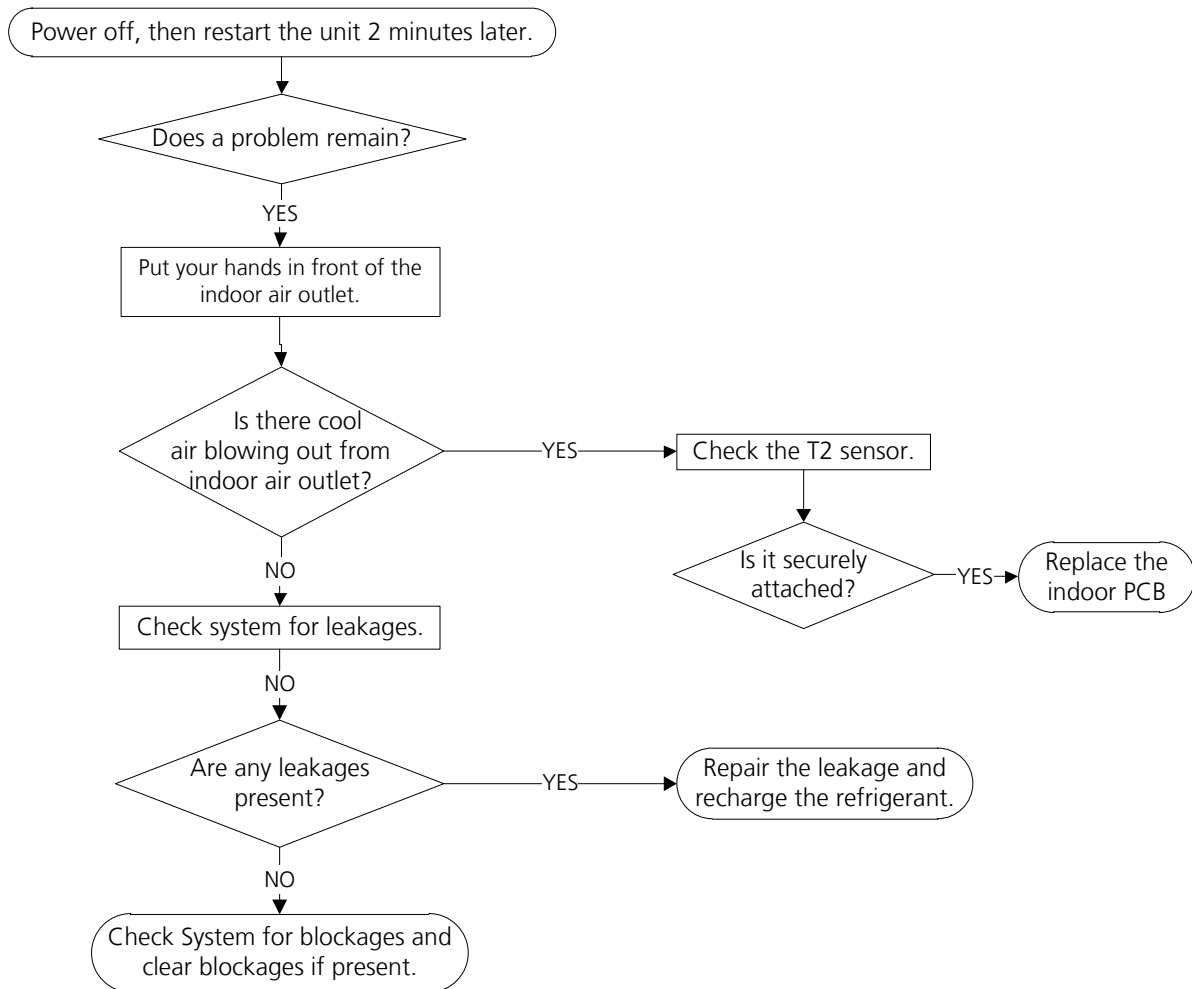

5.8 F0(Overload current protection diagnosis and solution)

Description: An abnormal current rise is detected by checking the specified current detection circuit.

Recommended parts to prepare:

- Outdoor PCB
- Connection wires
- Compressor

Troubleshooting and repair:

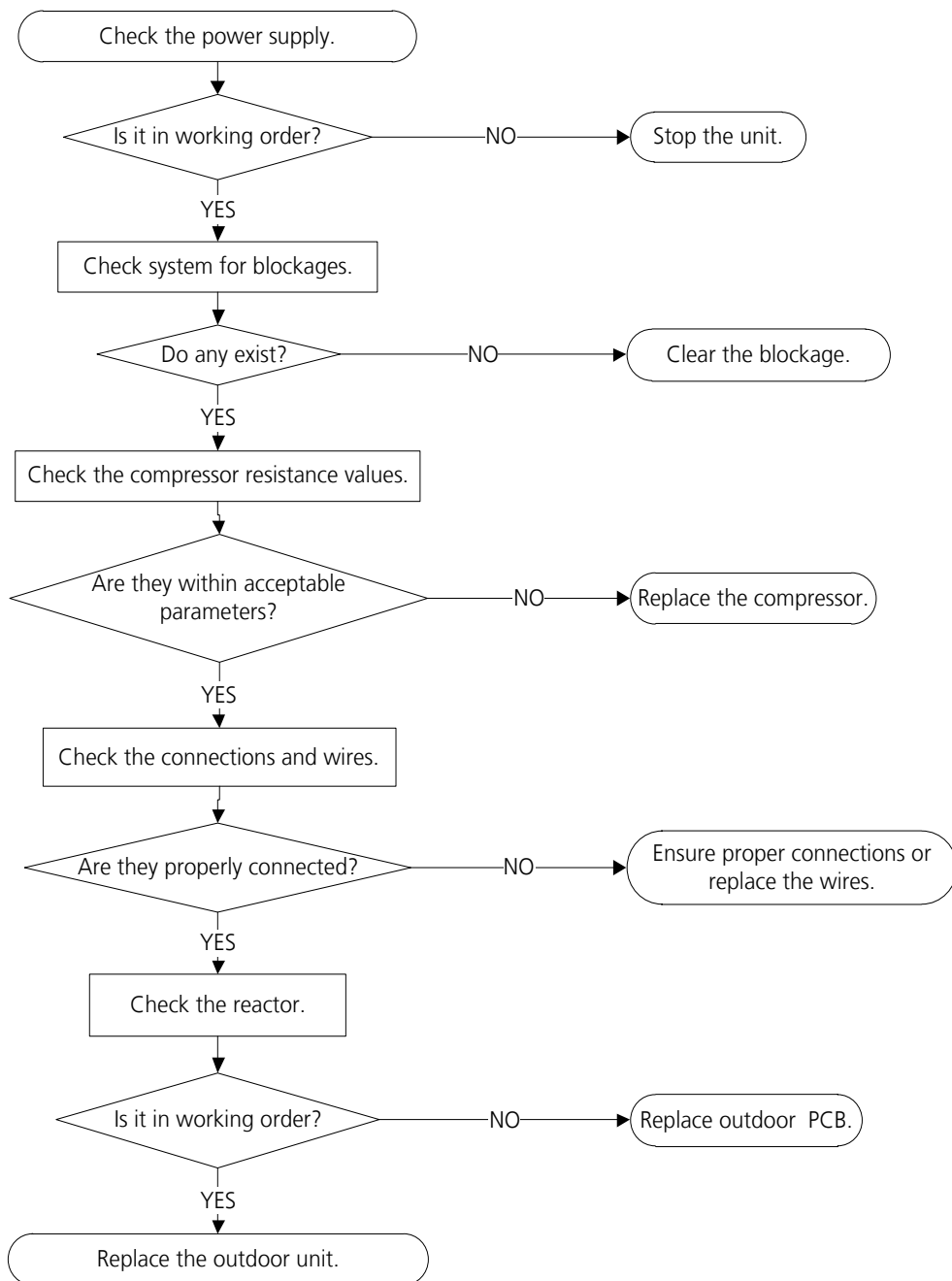

5.9 P0(IPM malfunction or IGBT over-strong current protection diagnosis and solution)

Description: When the voltage signal the IPM sends to the compressor drive chip is abnormal, the display LED shows “P0” and the AC turn off.

Recommended parts to prepare:

- Connection wires
- IPM module board
- Outdoor fan assembly
- Compressor
- Outdoor PCB

Troubleshooting and repair:

For 9K~24K:

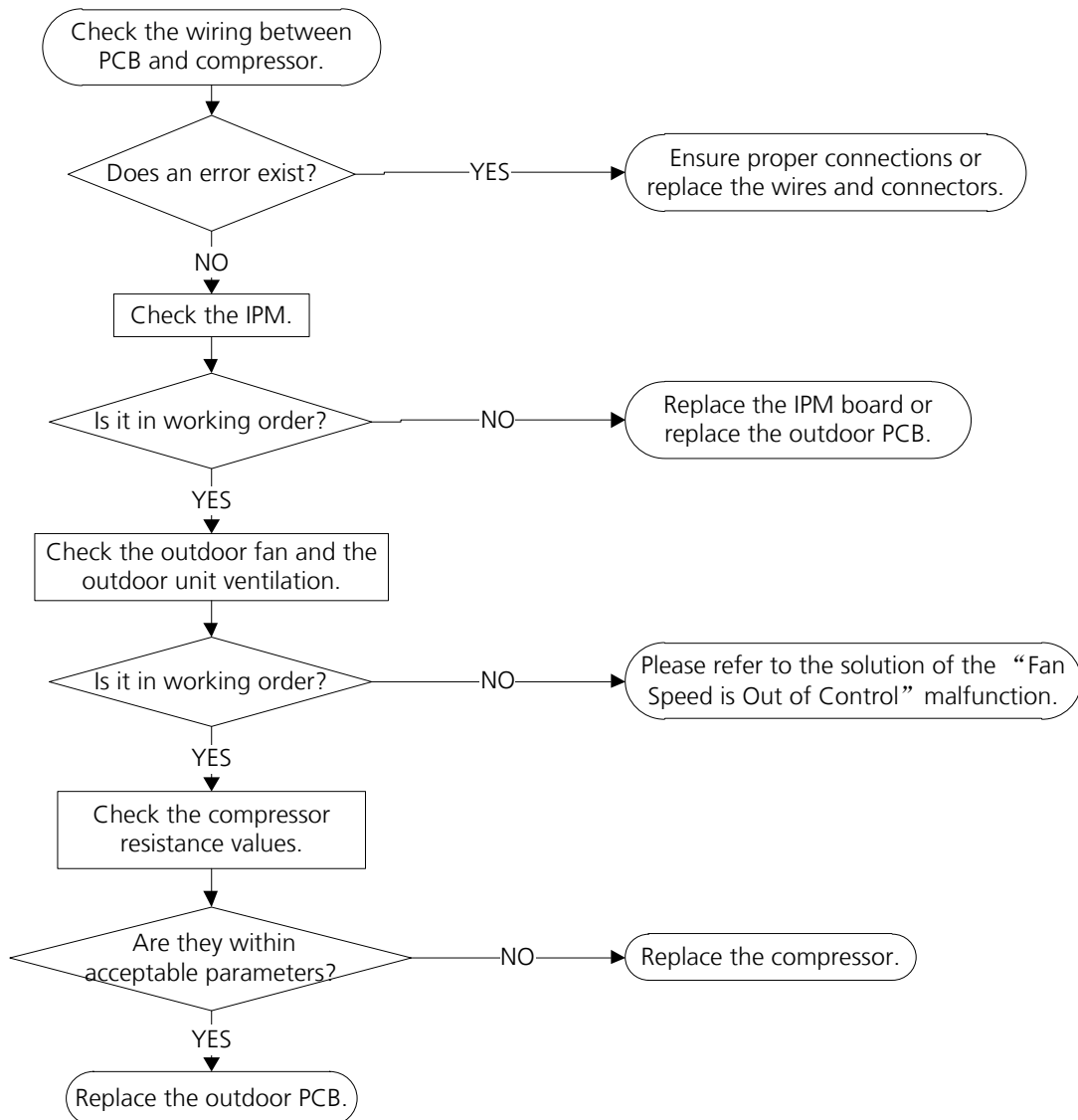

For 30K~36K:

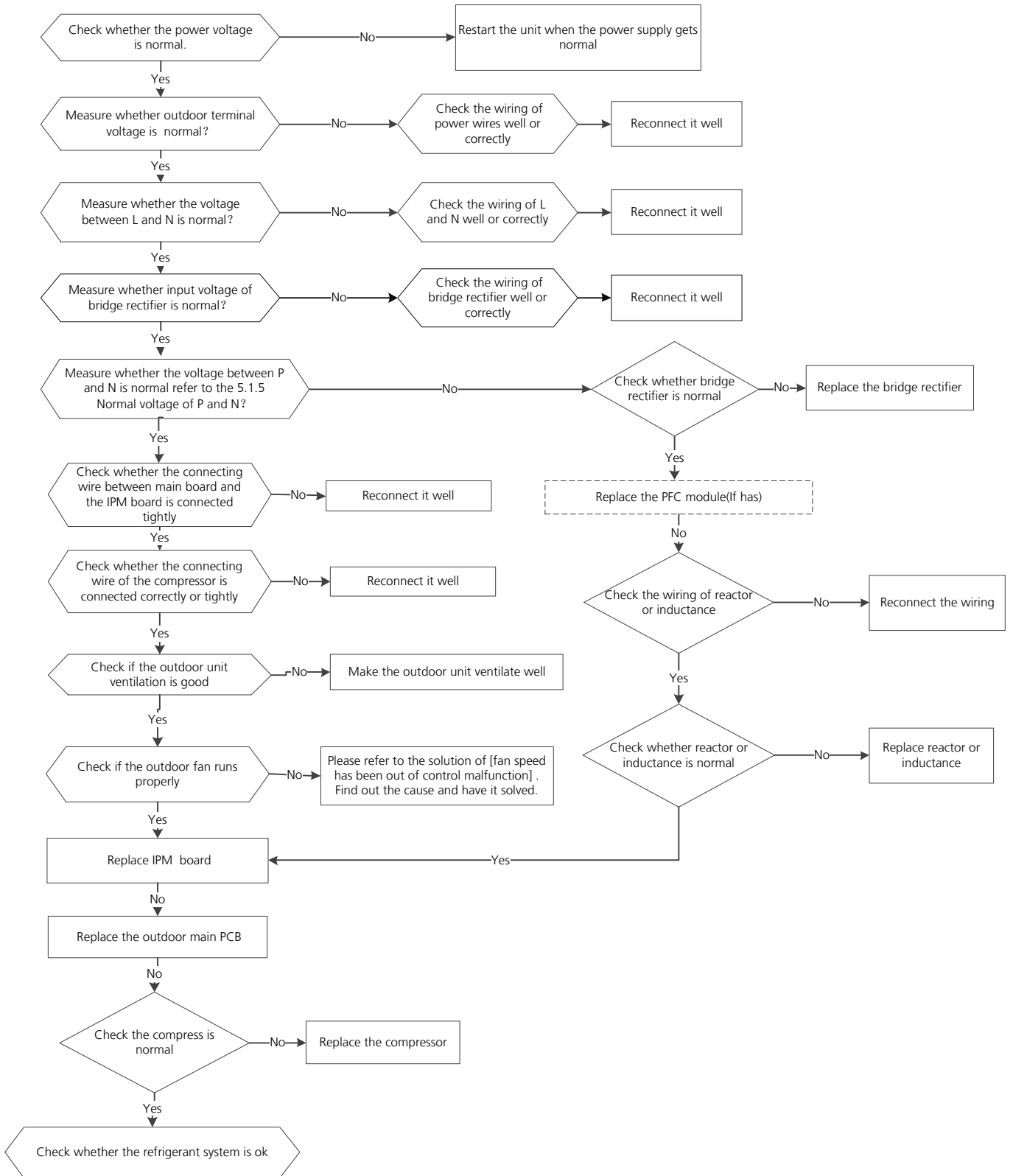

5.10 P1(Over voltage or too low voltage protection diagnosis and solution)

Description: Abnormal increases or decreases in voltage are detected by checking the specified voltage detection circuit.

Recommended parts to prepare:

- Power supply wires
- IPM module board
- PCB
- Reactor

Troubleshooting and repair:

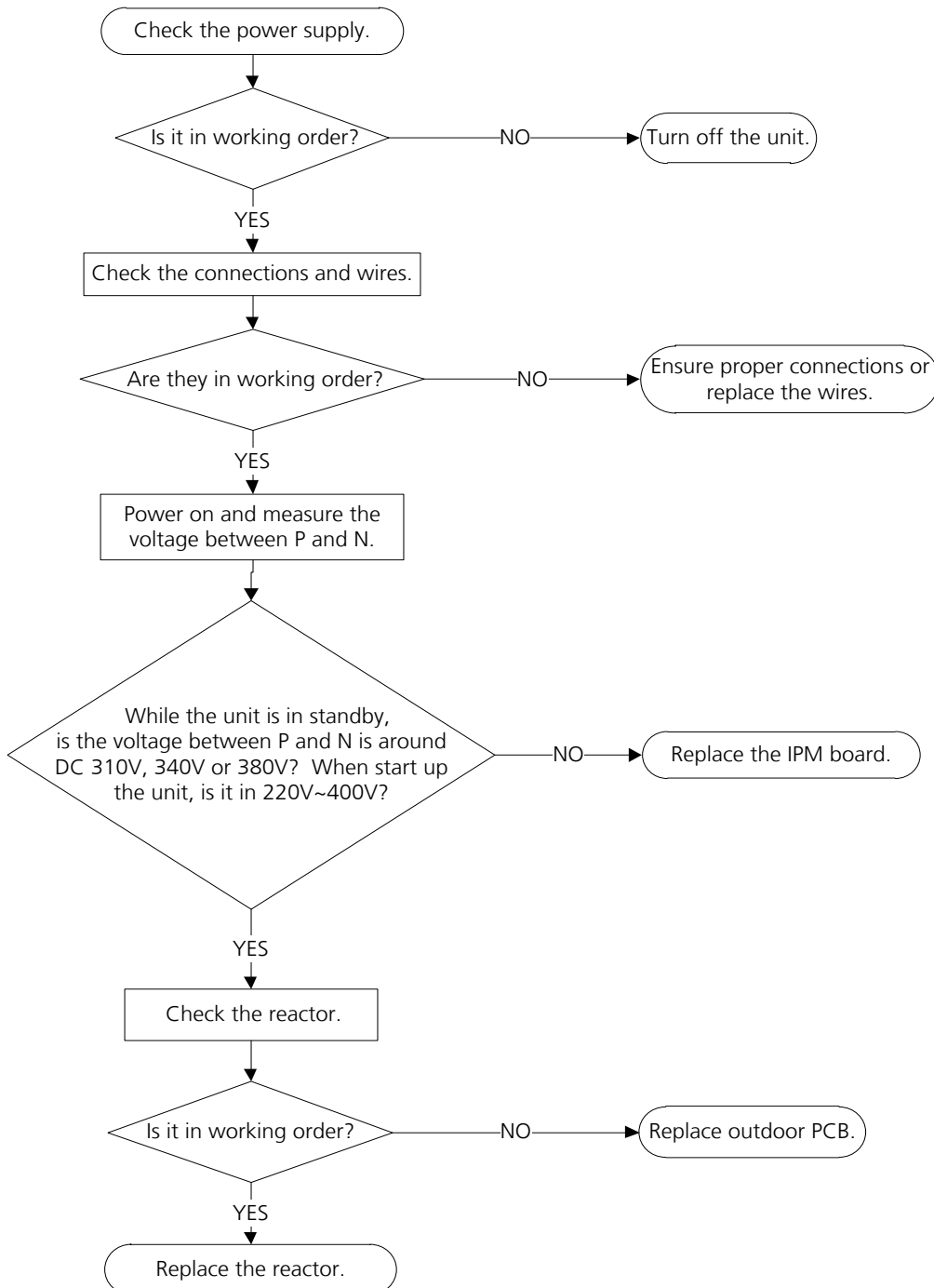

5.11 P2(High temperature protection of IPM module diagnosis and solution)

Description: If the temperature of IPM module is higher than setting value, the LED displays this failure code.

Recommended parts to prepare:

- Outdoor PCB
- IPM module board

Troubleshooting and repair:

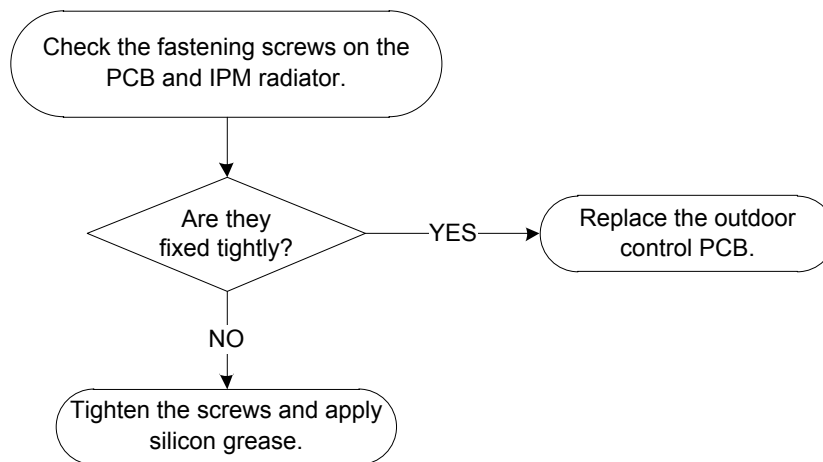

5.12 P4(Inverter compressor drive error diagnosis and solution)

Description: An abnormal inverter compressor drive is detected by a special detection circuit, including communication signal detection, voltage detection, compressor rotation speed signal detection and so on.

Recommended parts to prepare:

- Connection wires
- IPM module board
- Outdoor fan assembly
- Compressor
- Outdoor PCB

Troubleshooting and repair:

For 9K~24K:

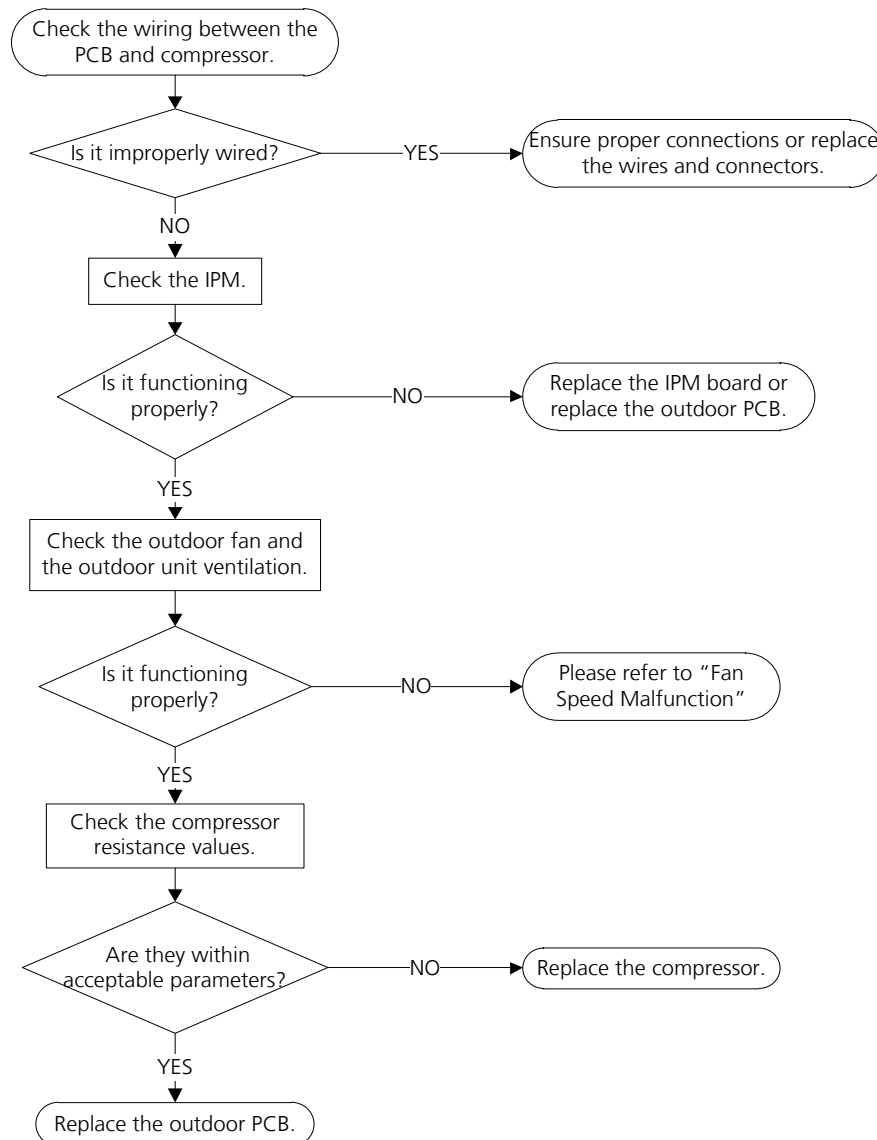

For 30K~36K:

At first test the resistance between every two ports of U, V, W of IPM and P, N. If any result of them is 0 or close to 0, the IPM is defective. Otherwise, please follow the procedure below:



Troubleshooting

5.13 P6(Low pressure protection diagnosis and solution)

Description: When the pressure of system reach a certain value, the low pressure protector will switch off. After the pressure resume to normal ,the protection code will disappear.

Recommended parts to prepare:

- Connection wires
- Pressure protector
- Fan motor
- PCB
- Refrigerant system

Troubleshooting and repair:

Only for 36K models:

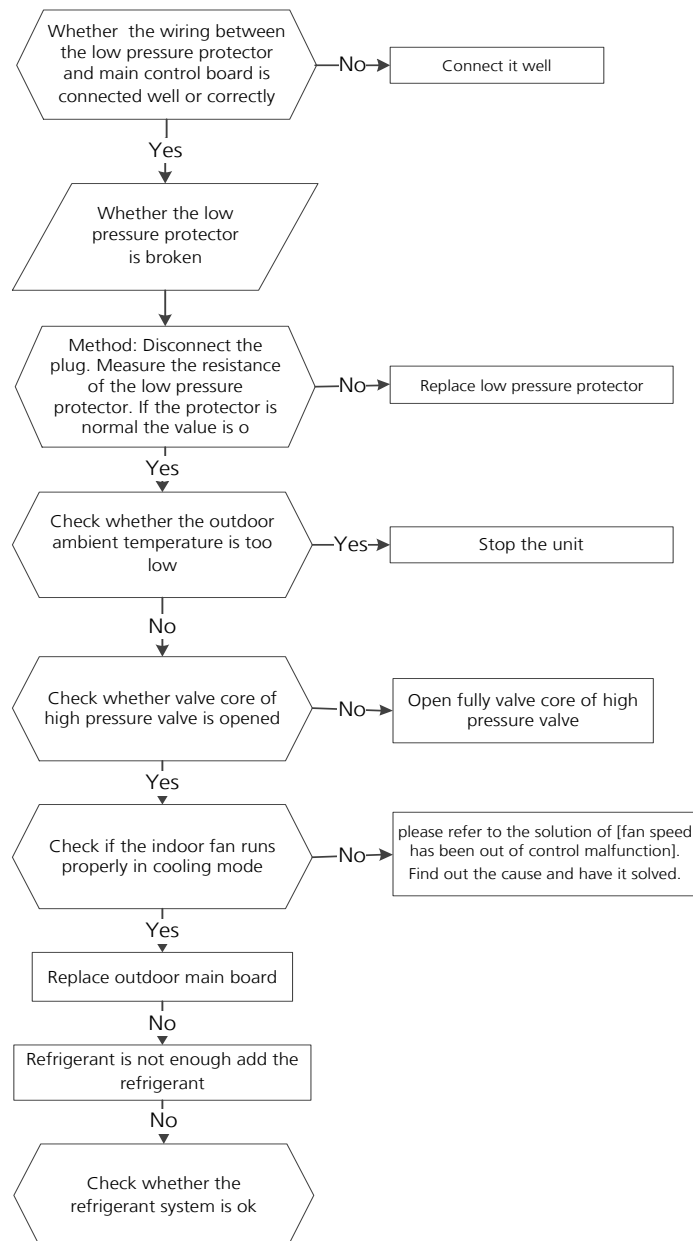

Appendix

Contents

i)	Temperature Sensor Resistance Value Table for T1, T2, T3, and T4 (°C – K) ..	113
ii)	Temperature Sensor Resistance Value Table for TP (°C – K).....	114
iii)	$\Delta T(^{\circ}F)$	115
iV)	Pressure On Service Port	116

i) Temperature Sensor Resistance Value Table for T1,T2,T3 and T4 (°C – K)

°C	°F	K Ohm	°C	°F	K Ohm	°C	°F	K Ohm	°C	°F	K Ohm
-20	-4	115.266	20	68	12.6431	60	140	2.35774	100	212	0.62973
-19	-2	108.146	21	70	12.0561	61	142	2.27249	101	214	0.61148
-18	0	101.517	22	72	11.5	62	144	2.19073	102	216	0.59386
-17	1	96.3423	23	73	10.9731	63	145	2.11241	103	217	0.57683
-16	3	89.5865	24	75	10.4736	64	147	2.03732	104	219	0.56038
-15	5	84.219	25	77	10	65	149	1.96532	105	221	0.54448
-14	7	79.311	26	79	9.55074	66	151	1.89627	106	223	0.52912
-13	9	74.536	27	81	9.12445	67	153	1.83003	107	225	0.51426
-12	10	70.1698	28	82	8.71983	68	154	1.76647	108	226	0.49989
-11	12	66.0898	29	84	8.33566	69	156	1.70547	109	228	0.486
-10	14	62.2756	30	86	7.97078	70	158	1.64691	110	230	0.47256
-9	16	58.7079	31	88	7.62411	71	160	1.59068	111	232	0.45957
-8	18	56.3694	32	90	7.29464	72	162	1.53668	112	234	0.44699
-7	19	52.2438	33	91	6.98142	73	163	1.48481	113	235	0.43482
-6	21	49.3161	34	93	6.68355	74	165	1.43498	114	237	0.42304
-5	23	46.5725	35	95	6.40021	75	167	1.38703	115	239	0.41164
-4	25	44	36	97	6.13059	76	169	1.34105	116	241	0.4006
-3	27	41.5878	37	99	5.87359	77	171	1.29078	117	243	0.38991
-2	28	39.8239	38	100	5.62961	78	172	1.25423	118	244	0.37956
-1	30	37.1988	39	102	5.39689	79	174	1.2133	119	246	0.36954
0	32	35.2024	40	104	5.17519	80	176	1.17393	120	248	0.35982
1	34	33.3269	41	106	4.96392	81	178	1.13604	121	250	0.35042
2	36	31.5635	42	108	4.76253	82	180	1.09958	122	252	0.3413
3	37	29.9058	43	109	4.5705	83	181	1.06448	123	253	0.33246
4	39	28.3459	44	111	4.38736	84	183	1.03069	124	255	0.3239
5	41	26.8778	45	113	4.21263	85	185	0.99815	125	257	0.31559
6	43	25.4954	46	115	4.04589	86	187	0.96681	126	259	0.30754
7	45	24.1932	47	117	3.88673	87	189	0.93662	127	261	0.29974
8	46	22.5662	48	118	3.73476	88	190	0.90753	128	262	0.29216
9	48	21.8094	49	120	3.58962	89	192	0.8795	129	264	0.28482
10	50	20.7184	50	122	3.45097	90	194	0.85248	130	266	0.2777
11	52	19.6891	51	124	3.31847	91	196	0.82643	131	268	0.27078
12	54	18.7177	52	126	3.19183	92	198	0.80132	132	270	0.26408
13	55	17.8005	53	127	3.07075	93	199	0.77709	133	271	0.25757
14	57	16.9341	54	129	2.95896	94	201	0.75373	134	273	0.25125
15	59	16.1156	55	131	2.84421	95	203	0.73119	135	275	0.24512
16	61	15.3418	56	133	2.73823	96	205	0.70944	136	277	0.23916
17	63	14.6181	57	135	2.63682	97	207	0.68844	137	279	0.23338
18	64	13.918	58	136	2.53973	98	208	0.66818	138	280	0.22776
19	66	13.2631	59	138	2.44677	99	210	0.64862	139	282	0.22231

ii) Temperature Sensor Resistance Value Table for TP (°C – K)

°C	°F	K Ohm	°C	°F	K Ohm	°C	°F	K Ohm	°C	°F	K Ohm
-20	-4	542.7	20	68	68.66	60	140	13.59	100	212	3.702
-19	-2	511.9	21	70	65.62	61	142	13.11	101	214	3.595
-18	0	483	22	72	62.73	62	144	12.65	102	216	3.492
-17	1	455.9	23	73	59.98	63	145	12.21	103	217	3.392
-16	3	430.5	24	75	57.37	64	147	11.79	104	219	3.296
-15	5	406.7	25	77	54.89	65	149	11.38	105	221	3.203
-14	7	384.3	26	79	52.53	66	151	10.99	106	223	3.113
-13	9	363.3	27	81	50.28	67	153	10.61	107	225	3.025
-12	10	343.6	28	82	48.14	68	154	10.25	108	226	2.941
-11	12	325.1	29	84	46.11	69	156	9.902	109	228	2.86
-10	14	307.7	30	86	44.17	70	158	9.569	110	230	2.781
-9	16	291.3	31	88	42.33	71	160	9.248	111	232	2.704
-8	18	275.9	32	90	40.57	72	162	8.94	112	234	2.63
-7	19	261.4	33	91	38.89	73	163	8.643	113	235	2.559
-6	21	247.8	34	93	37.3	74	165	8.358	114	237	2.489
-5	23	234.9	35	95	35.78	75	167	8.084	115	239	2.422
-4	25	222.8	36	97	34.32	76	169	7.82	116	241	2.357
-3	27	211.4	37	99	32.94	77	171	7.566	117	243	2.294
-2	28	200.7	38	100	31.62	78	172	7.321	118	244	2.233
-1	30	190.5	39	102	30.36	79	174	7.086	119	246	2.174
0	32	180.9	40	104	29.15	80	176	6.859	120	248	2.117
1	34	171.9	41	106	28	81	178	6.641	121	250	2.061
2	36	163.3	42	108	26.9	82	180	6.43	122	252	2.007
3	37	155.2	43	109	25.86	83	181	6.228	123	253	1.955
4	39	147.6	44	111	24.85	84	183	6.033	124	255	1.905
5	41	140.4	45	113	23.89	85	185	5.844	125	257	1.856
6	43	133.5	46	115	22.89	86	187	5.663	126	259	1.808
7	45	127.1	47	117	22.1	87	189	5.488	127	261	1.762
8	46	121	48	118	21.26	88	190	5.32	128	262	1.717
9	48	115.2	49	120	20.46	89	192	5.157	129	264	1.674
10	50	109.8	50	122	19.69	90	194	5	130	266	1.632
11	52	104.6	51	124	18.96	91	196	4.849			
12	54	99.69	52	126	18.26	92	198	4.703			
13	55	95.05	53	127	17.58	93	199	4.562			
14	57	90.66	54	129	16.94	94	201	4.426			
15	59	86.49	55	131	16.32	95	203	4.294			
16	61	82.54	56	133	15.73	96	205	4.167			
17	63	78.79	57	135	15.16	97	207	4.045			
18	64	75.24	58	136	14.62	98	208	3.927			
19	66	71.86	59	138	14.09	99	210	3.812			

iii)

$$\Delta T(^{\circ}\text{F}) = \frac{9\Delta T(^{\circ}\text{C})}{5}$$

$^{\circ}\text{C}$	$^{\circ}\text{F}$	$^{\circ}\text{C}$	$^{\circ}\text{F}$	$^{\circ}\text{C}$	$^{\circ}\text{F}$	$^{\circ}\text{C}$	$^{\circ}\text{F}$	$^{\circ}\text{C}$	$^{\circ}\text{F}$
-5	23	21	68.8	51	123.8	82	178.6	113	235.4
-4	24.8	22	71.6	52	125.6	83	181.4	114	237.2
-3	26.6	23	73.4	53	127.4	84	183.2	115	239
-2	28.4	24	75.2	54	128.2	85	185	116	240.8
	30.2	25	77	55	131	86	186.8	117	242.6
0	32	25.5	77.9	56	132.8	87	188.6	118	244.4
0.5	32.9	26	78.8	57	134.6	88	190.4	119	246.2
1	33.8	27	80.6	58	136.4	89	192.2	120	248
1.5	34.7	28	82.4	59	138.2	90	194	121	248.8
2	35.6	29	84.2	60	140	91	195.8	122	251.6
2.5	36.5	30	86	61	141.8	92	197.6	123	253.4
3	37.4	31	87.8	62	143.6	93	198.4	124	255.2
3.5	38.2	32	88.6	63	145.4	94	201.2	125	257
4	38.2	33	91.4	64	147.2	95	203	126	258.8
4.5	40.1	34	93.2	65	149	96	204.8	127	260.6
5	41	35	95	66	150.8	97	206.6	128	262.4
6	42.8	36	96.8	67	152.6	98	208.4	129	264.2
7	44.6	37	98.6	68	154.4	99	210.2	130	266
8	46.4	38	100.4	69	156.2	100	212	131	267.8
9	48.2	39	102.2	70	158	101	213.8	132	268.6
10	50	40	104	71	158.8	102	215.6	133	271.4
11	51.8	41	105.8	72	161.6	103	217.4	134	273.2
12	53.6	42	107.6	73	163.4	104	218.2	135	275
13	55.4	43	108.4	74	165.2	105	221	136	276.8
14	57.2	44	111.2	75	167	106	222.8	137	278.6
15	59	45	113	76	168.8	107	224.6	138	280.4
16	60.8	46	114.8	77	170.6	108	226.4	139	282.2
17	62.6	47	116.6	78	172.4	109	228.2	140	284
18	64.4	48	118.4	79	174.2	110	230	141	285.8
19	66.2	49	120.2	80	176	111	231.8	142	287.6
20	68	50	122	81	177.8	112	233.6	143	288.4

iV) Pressure On Service Port(R410A)

Cooling chart(R410A):

°F(°C)	ODU(DB)		0(-17)	5(-15)	15 (9.44)	45 (7.22)	75 (23.89)	85 (29.44)	95 (35)	105 (40.56)	115 (46.11)	120 (48.89)
	IDU(DB/WB)											
BAR	70/59 (21.11/15)		6.4	6.5	7.3	8.0	8.2	7.8	8.1	8.6	10.1	10.6
	75/63 (23.89/17.22)		6.7	6.8	7.9	8.6	8.6	8.3	8.7	9.1	10.7	11.2
	80/67 (26.67/19.44)		7.1	7.2	8.5	9.5	9.3	8.9	9.1	9.6	11.2	11.9
	90/73 (32.22/22.78)		7.7	7.8	9.6	10.5	10.3	9.5	10.0	10.6	12.4	13.0
PSI	70/59 (21.11/15)		93	94	106	116	119	113	117	125	147	154
	75/63 (23.89/17.22)		97	99	115	125	124	120	126	132	155	162
	80/67 (26.67/19.44)		103	104	123	138	135	129	132	140	162	173
	90/73 (32.22/22.78)		112	113	139	152	149	138	145	154	180	189
MPa	70/59 (21.11/15)		0.64	0.65	0.73	0.8	0.82	0.78	0.81	0.86	1.01	1.06
	75/63 (23.89/17.22)		0.67	0.68	0.79	0.86	0.86	0.83	0.87	0.91	1.07	1.12
	80/67 (26.67/19.44)		0.71	0.72	0.85	0.95	0.93	0.89	0.91	0.96	1.12	1.19
	90/73 (32.22/22.78)		0.77	0.78	0.96	1.05	1.03	0.95	1	1.06	1.24	1.3

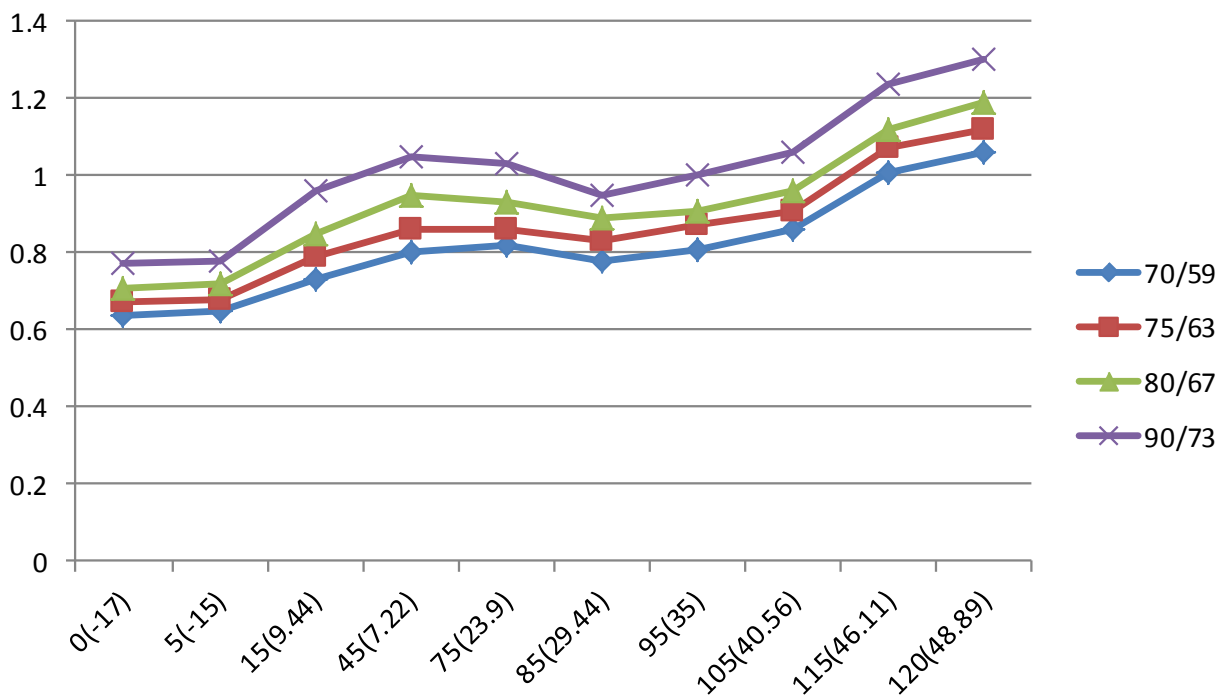

Heating chart(R410A):

°F(°C)	ODU(DB/WB)	57/53 (13.89/11.67)	47/43 (8.33/6.11)	37/33 (2.78/0.56)	27/23 (-2.78/-5)	17/13 (-8.33/ -10.56)	0/-2 (-17/-19)	-17/-18 (-27/-28)
	IDU(DB)							
BAR	55(12.78)	30.3	28.5	25.3	22.8	20.8	18.5	16.5
	65(18.33)	32.5	30.0	26.6	25.4	23.3	20.5	19.0
	75(23.89)	33.8	31.5	27.8	26.3	24.9	21.5	20.0
PSI	55(12.78)	439	413	367	330	302	268	239
	65(18.33)	471	435	386	368	339	297	276
	75(23.89)	489	457	403	381	362	312	290
MPa	55(12.78)	3.03	2.85	2.53	2.28	2.08	1.85	1.65
	65(18.33)	3.25	3.00	2.66	2.54	2.33	2.05	1.90
	75(23.89)	3.38	3.15	2.78	2.63	2.49	2.15	2.00

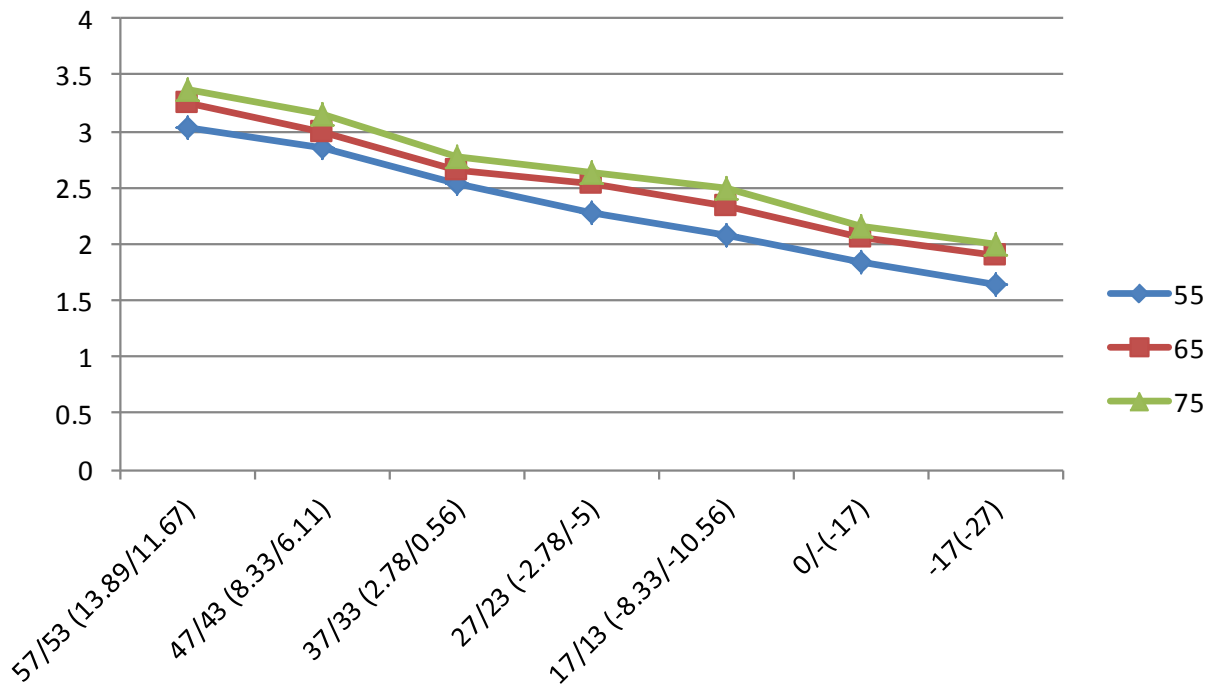

System Pressure Table-R410A

Pressure			Temperature		Pressure			Temperature	
Kpa	bar	PSI	°C	°F	Kpa	bar	PSI	°C	°F
100	1	14.5	-51.623	-60.921	2350	23.5	340.75	38.817	101.871
150	1.5	21.75	-43.327	-45.989	2400	24	348	39.68	103.424
200	2	29	-36.992	-34.586	2450	24.5	355.25	40.531	104.956
250	2.5	36.25	-31.795	-25.231	2500	25	362.5	41.368	106.462
300	3	43.5	-27.351	-17.232	2550	25.5	369.75	42.192	107.946
350	3.5	50.75	-23.448	-10.206	2600	26	377	43.004	109.407
400	4	58	-19.953	-3.915	2650	26.5	384.25	43.804	110.847
450	4.5	65.25	-16.779	1.798	2700	27	391.5	44.592	112.266
500	5	72.5	-13.863	7.047	2750	27.5	398.75	45.37	113.666
550	5.5	79.75	-11.162	11.908	2800	28	406	46.136	115.045
600	6	87	-8.643	16.444	2850	28.5	413.25	46.892	116.406
650	6.5	94.25	-6.277	20.701	2900	29	420.5	47.638	117.748
700	7	101.5	-4.046	24.716	2950	29.5	427.75	48.374	119.073
750	7.5	108.75	-1.933	28.521	3000	30	435	49.101	120.382
800	8	116	0.076	32.137	3050	30.5	442.25	49.818	121.672
850	8.5	123.25	1.993	35.587	3100	31	449.5	50.525	122.945
900	9	130.5	3.826	38.888	3150	31.5	456.75	51.224	124.203
950	9.5	137.75	5.584	42.052	3200	32	464	51.914	125.445
1000	10	145	7.274	45.093	3250	32.5	471.25	52.596	126.673
1050	10.5	152.25	8.901	48.022	3300	33	478.5	53.27	127.886
1100	11	159.5	10.471	50.848	3350	33.5	485.75	53.935	129.083
1150	11.5	166.75	11.988	53.578	3400	34	493	54.593	130.267
1200	12	174	13.457	56.223	3450	34.5	500.25	55.243	131.437
1250	12.5	181.25	14.879	58.782	3500	35	507.5	55.885	132.593
1300	13	188.5	16.26	61.268	3550	35.5	514.75	56.52	133.736
1350	13.5	195.75	17.602	63.684	3600	36	522	57.148	134.866
1400	14	203	18.906	66.031	3650	36.5	529.25	57.769	135.984
1450	14.5	210.25	20.176	68.317	3700	37	536.5	58.383	137.089
1500	15	217.5	21.414	70.545	3750	37.5	543.75	58.99	138.182
1550	15.5	224.75	22.621	72.718	3800	38	551	59.591	139.264
1600	16	232	23.799	74.838	3850	38.5	558.25	60.185	140.333
1650	16.5	239.25	24.949	76.908	3900	39	565.5	60.773	141.391
1700	17	246.5	26.074	78.933	3950	39.5	572.75	61.355	142.439
1750	17.5	253.75	27.174	80.913	4000	40	580	61.93	143.474
1800	18	261	28.251	82.852	4050	40.5	587.25	62.499	144.498
1850	18.5	268.25	29.305	84.749	4100	41	594.5	63.063	145.513
1900	19	275.5	30.338	86.608	4150	41.5	601.75	63.62	146.516
1950	19.5	282.75	31.351	88.432	4200	42	609	64.172	147.510
2000	20	290	32.344	90.219	4250	42.5	616.25	64.719	148.494
2050	20.5	297.25	33.319	91.974	4300	43	623.5	65.259	149.466
2100	21	304.5	34.276	93.697	4350	43.5	630.75	65.795	150.431
2150	21.5	311.75	35.215	95.387	4400	44	638	66.324	151.383
2200	22	319	36.139	97.050	4450	44.5	645.25	66.849	152.328
2250	22.5	326.25	37.047	98.685	4500	45	652.5	67.368	153.262
2300	23	333.5	37.939	100.290					