



TM_DUCT_60R410A_3D INVERTER_US_S_NA_171113

CEILING CONCEALED DUCT R410A 60HZ 3D INVERTER CONTROL

2017 TECHNICAL MANUAL

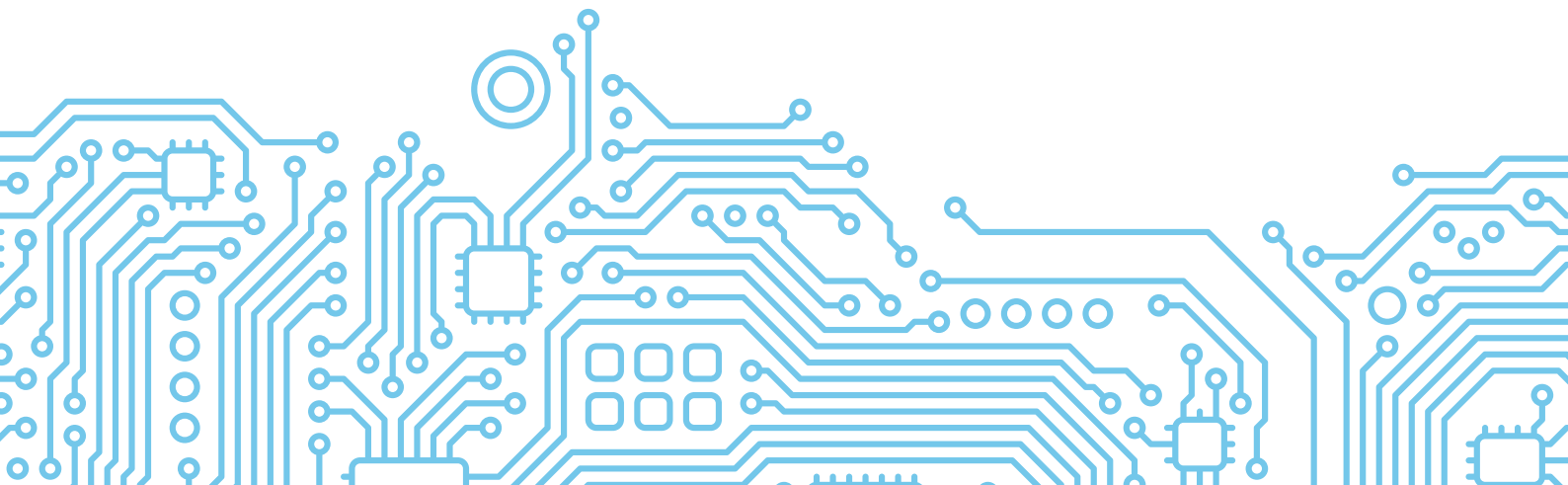
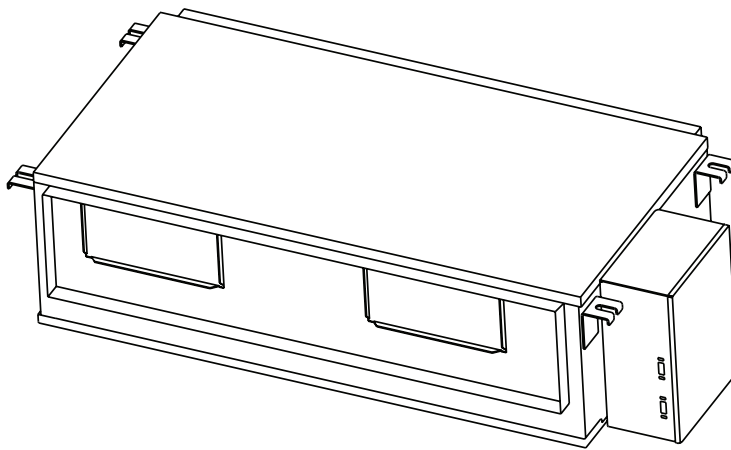
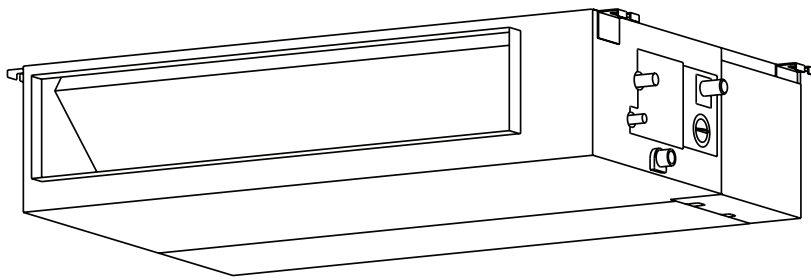

Table of Contents

Page

1. Specifications	4
1. Model Reference	
2. General Specifications	
3. Dimensional Drawings	
4. Centre of Gravity	
5. Electrical Wiring Diagrams	
6. Refrigerant Cycle Diagrams	
7. Capacity Correction Factor for Height Difference	
8. Noise Data	
9. Electrical Characteristics	
10. Static Pressure	
2. Product Features	56
1. Operation Modes and Functions	
2. Remote Controller Functions	
3. Installation	72
1. Installation Overview	
2. Location Selection	
3. Indoor Unit Installation	
4. Outdoor Unit Installation	
5. Drainage Pipe Installation	
6. Refrigerant Pipe Installation	
7. Vacuum Drying and Leakage checking	
8. Additional Refrigerant Charge	
9. Engineering of Insulation	
10. Engineering of Electrical Wiring	
11. Test Operation	

4. Static Pressure Design	87
1. Introduction	
2. Charts for friction losses in round ducts	
3. Dynamic losses	
4. Corresponding relation between Rectangular duct and Round duct	
5. Method for duct calculation	
6. Unit conversion	
7. Recommended outlet velocity for different occasions	

Specifications

Contents

1.	Model Reference.....	5
2.	General Specifications.....	6
3.	Dimensional Drawings.....	12
4.	Centre of Gravity.....	16
5.	Electrical Wiring Diagrams.....	19
6.	Refrigerant Cycle Diagrams.....	31
7.	Capacity Correction Factor for Height Difference.....	34
8.	Noise Data.....	40
9.	Electrical Characteristics.....	46
10.	Static Pressure.....	47

1. Model Reference

Refer to the following table to determine the specific indoor and outdoor unit model number of your purchased equipment.

Indoor Unit Model	Outdoor Unit Model	Capacity (Btu/h)	Power Supply
MTIU-09HWFN1-M	MOBA30-09HFN1-MT0W	9K	1Φ, 208/230V~, 60Hz
MTIU-12HWFN1-M	MOB30-12HFN1-MT0W	12K	
MTIU-18HWFN1-M	MOCA31-18HFN1-MT0W	18K	
MTIU-24HWFN1-M	MOD31-24HFN1-MT0W	24K	
MTI-36HWFN1-M	MOD30U-36HFN1-M	36K	
MTI-48HWFN1-M	MOE30U-48HFN1-M	48K	
MHG-60HWFN1-MW	MOE30U-60HFN1-M	60K	

2. General Specifications

Indoor Model		MTIU-09HWFN1-M	MTIU-12HWFN1-M	MTIU-18HWFN1-M	
Outdoor Model		MOBA30-09HFN1-MTOW	MOB30-12HFN1-MTOW	MOCA31-18HFN1-MTOW	
Power supply	V-ph-Hz	208~230-1-60	208~230-1-60	208~230-1-60	
Minimum circuit ampacity	A	10	12	15	
Max.fuse	A	15	15	20	
Indoor fan motor	Model	ZKFN-55-8-22	ZKFN-55-8-22	ZKFN-160-8-1-2	
	Qty	1	1	1	
	Input	W	130	130	
	RLA	A	0.9	1	
	LRA	A	/	/	
	Winding Resistance	Ω	/	/	
	Capacitor	μ F	/	/	
Speed	r/min	1170/1030/850	1170/1030/850	850/700/450	
Indoor air flow (Hi/Med/Lo) (No duct)	m ³ /h	600/480/300	600/480/300	900/765/630	
Indoor air flow (Hi/Med/Lo) (No duct)	CFM	353/283/177	353/283/177	530/450/371	
ESP	Range	Pa	0-40	0-100	
	Range	In. WG.	0-0.16	0-0.40	
Indoor noise level (Hi/Med/Lo)	dB(A)	35.5/30.5/27.5	37.5/33/27.5	41.5/38.5/36	
Throttle type		/	/	/	
Indoor unit	Dimension (WxDxH)	mm	700x450x200	700x450x200	880x674x210
		inch	27.55x17.71x7.87	27.55x17.71x7.87	34.65x28.53x8.27
	Packing(WxDxH)	mm	860x540x275	860x540x275	1070x725x270
		inch	33.86x21.26x10.83	33.86x21.26x10.83	42.13x28.53x10.63
	Net/Gross weight	kg	17.7/21.9	17.8/22	23.8/29.5
		lbs.	39/48.3	39/48.5	52.5/65.0
Design pressure	PSIG	550/340 PSIG	550/340 PSIG	550/340 PSIG	
Drainage water pipe diameter	mm	OD Φ 25	OD Φ 25	OD Φ 25	
Refrigerant piping	Liquid side/ Gas side	mm	Φ 6.35/ Φ 9.52(1/4"/3/8")	Φ 6.35/ Φ 12.7(1/4"/1/2")	Φ 6.35/ Φ 12.7(1/4"/1/2")
Controller		Wired control	Wired control	Wired control	
Room temperature	Cooling	C	17~32	17~32	17~32
		F	62~90	62~90	62~90
	Heating	C	0~30	0~30	0~30
		F	32~86	32~86	32~86
Operation temperature	C	17~30	17~30	17~30	
	F	62~86	62~86	62~86	
Compressor	Model	ASN98D22UFZ	ASM98D32UFZ	ASM135D23UFZ	
	Type	ROTARY	ROTARY	ROTARY	
	Brand	GMCC	GMCC	GMCC	
	Capacity	Btu/h	10014	10093	13836
	Input	W	748	730	1035
	Rated current (RLA)	A	5.35	5.08	7.32
	Locked rotor Amp(LRA)	A	----	----	----
	Thermal protector position		INTERNAL	----	INTERNAL
	Capacitor	μ F	----	----	----
	Refrigerant oil	ml	ESTER OIL VG74/370	ESTER OIL VG74/370	ESTER OIL VG74/450

Outdoor fan motor	Model		ZKFN-40-8-1L	ZKFN-40-8-1L	ZKFN-50-8-2
	Qty		1	1	1
	Input	W	63	63	115
	RLA	A	0.4	0.4	0.6
	LRA	A	----	----	----
	Winding Resistance	Ω	----	----	----
	Capacitor	uF	----	----	----
	Speed	r/min	800	800	850
Outdoor air flow (Max.)		m ³ /h	1800	1900	2500
Outdoor air flow (Max.)		CFM	1060	1120	1470
Outdoor noise level		dB(A)	54.5	58	59
Throttle type			Capillary +EXV	Capillary +EXV	Capillary +EXV
Outdoor unit	Dimension (WxDxH)	mm	770x300x555	800x333x554	845x363x702
		inch	30.31x11.81x21.85	31.5x13.11x21.81	33.27x14.29x27.64
	Packing (WxDxH)	mm	900x345x585	920x390x615	965x395x755
		inch	35.43x13.58x23.03	36.22x15.35x24.21	37.99x15.55x29.72
	Net/ Gross weight	kg	30.5/32.5	36.5/39.1	47.7/51
		lbs.	67.24/71.65	80.47/86.2	105.16/112.43
Refrigerant type/ Quantity	Type/Charged volume	Oz	R410A/38.8	R410A/40.6	R410A/68.8
Refrigerant precharge		ft	25	25	25
Additional charge for each ft		oz	0.16	0.16	0.16
Design pressure		PSIG	550/340	550/340	550/340
Refrigerant piping	Liquid side/ Gas side	mm(inch)	Φ6.35/Φ9.52(1/4"/3/8")	Φ6.35/Φ12.7(1/4"/1/2")	Φ6.35/Φ12.7(1/4"/1/2")
	Max. pipe length	m	25	25	30
		ft	82	82	98
	Max. difference in level	m	10	10	20
ft		33	33	66	
Ambient temperature	Cooling	C	-25~50	-25~50	-25~50
		F	-13~122	-13~122	-13~122
	Heating	C	-25~30	-25~30	-25~30
		F	-13~86	-13~86	-13~86
Qty'per 20' /40' /40'HQ		Indoor	214/461/519	214/461/519	120/264/297
Qty'per 20' /40' /40'HQ		Outdoor	166/344/344	108/219/292	102/216/216

Notes:

1) Capacities are based on the following conditions:

Cooling(T1): - Indoor Temperature 26.7°C(80°F) DB /19.4 °C(64°F) WB Heating: - Indoor Temperature 21.1°C(70°F) DB / ≤15.6°C(≤60°F) WB
 -Outdoor Temperature 35 °C(95°F) DB /23.9 °C(75°F) WB -Outdoor Temperature 8.3°C(47°F) DB / 6.1°C(43°F) WB
 -Interconnecting Piping Length 7.5 m(24.6ft) - Interconnecting Piping Length 7.5 m(24.6ft)
 - Level Difference of Zero. - Level Difference of Zero.

2) Capacities are Net Capacities.

3) Due to our policy of innovation some specifications may be changed without notification.

Indoor Model			MTIU-24HWFN1-M	MTI-36HWFN1-M
Outdoor Model			MOD31-24HFN1-MTOW	MOD30U-36HFN1-M
Power supply		V-ph-Hz	208~230-1-60	208~230-1-60
Minimum circuit ampacity		A	15	35
Max.fuse		A	25	50
Indoor fan motor	Model		ZKFN-160-8-1-2	ZKFN-300-8-1
	Qty		1	1
	Input	W	90.0	250
	RLA	A	1.5	1.6
	LRA	A	/	/
	Winding Resistance	Ω	/	/
	Capacitor	μ F	/	/
	Speed	r/min	880/820/690	1130/1050/990
Indoor air flow (Hi/Med/Lo) (No duct)		m ³ /h	1318.3/1178.2/739.3	1839/1551/1195
Indoor air flow (Hi/Med/Lo) (No duct)		CFM	776/693/435	1082/913/703
ESP	Range	Pa	0-160	0-160
	Range	In. WG.	0-0.64	0-0.64
Indoor noise level (Hi/Med/Lo)		dB(A)	44/41/34	45.5/42/38.5
Throttle type			/	/
Indoor unit	Dimension (WxDxH)	mm	1100x774x249	1360x774x249
		inch	43x30x10	54x30x10
	Packing(WxDxH)	mm	1305x805x305	1570x805x305
		inch	51x32x12	62x32x12
	Net/Gross weight	kg	39.4/46.7	48.3/55.5
		lbs.	87/103	106/122
Design pressure		PSIG	550/340 PSIG	550/340 PSIG
Drainage water pipe diameter		mm	OD Φ 25	OD Φ 25
Refrigerant piping	Liquid side/ Gas side	mm	Φ 9.52/ Φ 15.9(3/8"/5/8")	Φ 9.52/ Φ 15.9(3/8"/5/8")
Controller			Wired control	Wired control
Room temperature	Cooling	C	17~32	17~32
		F	62~90	62~90
	Heating	C	0~30	0~30
		F	32~86	32~86
Operation temperature		C	17~30	17~30
		F	62~86	62~86
Compressor	Model		ATF235D22UMT	ATF310D43UMT
	Type		ROTARY	ROTARY
	Brand		GMCC	GMCC
	Capacity	Btu/h	24345	32380
	Input	W	1970	2600
	Rated current (RLA)	A	6.95	5.10
	Locked rotor Amp(LRA)	A	----	----
	Thermal protector position		EXTERNAL	EXTERNAL
	Capacitor	μ F	----	----
	Refrigerant oil	ml	POE(VG74)/670	ESTER OIL VG74/1000
Outdoor fan motor	Model		ZKFN-120-8-2	ZKFN-120-8-2
	Qty		1	1
	Input	W	150	150
	RLA	A	0.6	1.0
	LRA	A	----	----
	Winding Resistance	Ω	----	----
	Capacitor	μ F	----	----
	Speed	r/min	810	950

Outdoor air flow (Max.)		m ³ /h	4000	4300
Outdoor air flow (Max.)		CFM	2354	2530
Outdoor noise level		dB(A)	59	63.5
Throttle type			Capillary +EXV	Capillary +EXV
Outdoor unit	Dimension (WxDxH)	mm	946x410x810	946x410x810
		inch	37.24x16.14x31.89	37.24x16.14x31.89
	Packing (WxDxH)	mm	1090x500x875	1090x500x875
		inch	42.91x19.69x34.45	42.91x19.69x34.45
	Net/ Gross weight	kg	64/69	67.4/73
		lbs.	141.09/152.12	148.59/160.94
Refrigerant type/Quantity	Type/Charged volume	Oz	R410A/82.9	R410A/108
Refrigerant precharge		ft	25	25
Additional charge for each ft		oz	0.32	0.32
Design pressure		PSIG	550/340	550/340
Refrigerant piping	Liquid side/ Gas side	mm(inch)	Ø9.52/Ø15.9(3/8"/5/8")	Ø9.52/Ø15.9(3/8"/5/8")
	Max. pipe length	m	50	65
		ft	164	213
	Max. difference in level	m	25	30
		ft	82	98
	Ambient temperature	Cooling	C	-25~50
F			-13~122	5~122
Heating		C	-25~30	-15~30
		F	-13~86	5~86
Qty/per 20' /40' /40'HQ		Indoor	77/161/184	49/105/120
Qty/per 20' /40' /40'HQ		Outdoor	44/96/144	44/96/144

Notes:

1) Capacities are based on the following conditions:

Cooling(T1): - Indoor Temperature 26.7°C(80°F) DB /19.4 °C(64°F) WB Heating: - Indoor Temperature 21.1°C(70°F) DB / ≤15.6°C(≤60°F) WB
 -Outdoor Temperature 35 °C(95°F) DB /23.9 °C(75°F) WB -Outdoor Temperature 8.3°C(47°F) DB / 6.1°C(43°F) WB
 -Interconnecting Piping Length 7.5 m(24.6ft) - Interconnecting Piping Length 7.5 m(24.6ft)
 - Level Difference of Zero. - Level Difference of Zero.

2) Capacities are Net Capacities.

3) Due to our policy of innovation some specifications may be changed without notification.

Indoor Model			MTI-48HWFN1-M	MHG-60HWFN1-MW
Outdoor Model			MOE30U-48HFN1-M	MOE30U-60HFN1-M
Power supply		V-ph-Hz	208~230-1-60	208~230-1-60
Minimum circuit ampacity		A	35	36
Max.fuse		A	50	50
Indoor fan motor	Model		ZKFN-560-8-1-1	ZKFN-700-8-1
	Qty		1	1
	Input	W	560	420
	RLA	A	2	3.65
	LRA	A	/	/
	Winding Resistance	Ω	/	/
	Capacitor	μ F	/	/
	Speed	r/min	1020/800/600	1060/910/790
Indoor air flow (Hi/Med/Lo) (No duct)		m ³ /h	2088.3/1752.7/1214.9	3665/2906/2145
Indoor air flow (Hi/Med/Lo) (No duct)		CFM	1229/1032/715	2157/1710/1263
ESP	Range	Pa	0-160	0-200
	Range	In. WG.	0-0.64	0-0.8
Indoor noise level (Hi/Med/Lo)		dB(A)	50.5/48.5/46	57/54/51
Throttle type			/	/
Indoor unit	Dimension (WxDxH)	mm	1200x874x300	1400x858x440
		inch	47.24x34.41x11.81	55/34/17
	Packing(WxDxH)	mm	1405x915x355	1605x910x505
		inch	55.31x36.02x13.98	63/36/20
	Net/Gross weight	kg	54.3/64.3	74/86
		lbs.	54.3/64.3	163/190
Design pressure		PSIG	550/340 PSIG	550/340 PSIG
Drainage water pipe diameter		mm	OD Φ 25	OD Φ 25
Refrigerant piping	Liquid side/ Gas side	mm	Φ 9.52/ Φ 15.9(3/8"/5/8")	Φ 9.52/ Φ 19(3/8"/3/4")
Controller			Wired control	Wired control
Room temperature	Cooling	C	17~32	17~32
		F	62~90	62~90
	Heating	C	0~30	0~30
		F	32~86	32~86
Operation temperature		C	17~30	17~30
		F	62~86	62~86
Compressor	Model		ATQ420D1UMU	ATQ420D1UMU
	Type		ROTARY	ROTARY
	Brand		GMCC	GMCC
	Capacity	Btu/h	44697	44697
	Input	W	3420	3420
	Rated current (RLA)	A	6.85	6.85
	Locked rotor Amp(LRA)	A	----	/
	Thermal protector position		INTERNAL	INTERNAL
	Capacitor	μ F	----	----
	Refrigerant oil	ml	Ester Oil VG74/1400	Ester Oil VG74/1400
Outdoor fan motor	Model		ZKFN-85-8-22	ZKFN-85-8-22
	Qty		2	2
	Input	W	126	126
	RLA	A	1.2	1.2
	LRA	A	----	----
	Winding Resistance	Ω	----	----
	Capacitor	μ F	----	----
	Speed	r/min	900	900

Outdoor air flow (Max.)		m ³ /h	7600	7500
Outdoor air flow (Max.)		CFM	4470	4414
Outdoor noise level		dB(A)	63	64
Throttle type			Capillary +EXV	Capillary +EXV
Outdoor unit	Dimension (WxDxH)	mm	952x415x1333	952x415x1333
		inch	37.48x16.34x52.48	37/16/52
	Packing (WxDxH)	mm	1095x495x1480	1095x495x1480
		inch	43.11x19.49x58.27	43/19/58
	Net/ Gross weight	kg	101/115	102.1/115.4
lbs.		222.66/253.53	224.9/254.4	
Refrigerant type/Quantity	Type/Charged volume	Oz	R410A/148	R410A/163
Refrigerant precharge		ft	25	25
Additional charge for each ft		oz	0.32	0.32
Design pressure		PSIG	550/340	550/340
Refrigerant piping	Liquid side/ Gas side	mm(inch)	Ø9.52/Ø15.9(3/8"/5/8")	Ø9.52/Ø19(3/8"/3/4")
	Max. pipe length	m	65	65
		ft	213	213
	Max. difference in level	m	30	30
ft		98	98	
Ambient temperature	Cooling	C	-15~50	-15~50
		F	5~122	5~122
	Heating	C	-15~30	-15~30
		F	5~86	5~86
Qty'per 20' /40' /40'HQ		Indoor	62/130/149	35/72/86
Qty'per 20' /40' /40'HQ		Outdoor	22/46/46	22/48/48

Notes:

1) Capacities are based on the following conditions:

- | | |
|---|---|
| Cooling(T1): - Indoor Temperature 26.7°C(80°F) DB /19.4 °C(64°F) WB | Heating: - Indoor Temperature 21.1°C(70°F) DB / ≤15.6°C(≤60°F) WB |
| -Outdoor Temperature 35 °C(95°F) DB /23.9 °C(75°F) WB | -Outdoor Temperature 8.3°C(47°F) DB / 6.1°C(43°F) WB |
| -Interconnecting Piping Length 7.5 m(24.6ft) | - Interconnecting Piping Length 7.5 m(24.6ft) |
| - Level Difference of Zero. | - Level Difference of Zero. |

2) Capacities are Net Capacities.

3) Due to our policy of innovation some specifications may be changed without notification.

3. Dimensional Drawings

3.1 Indoor Unit

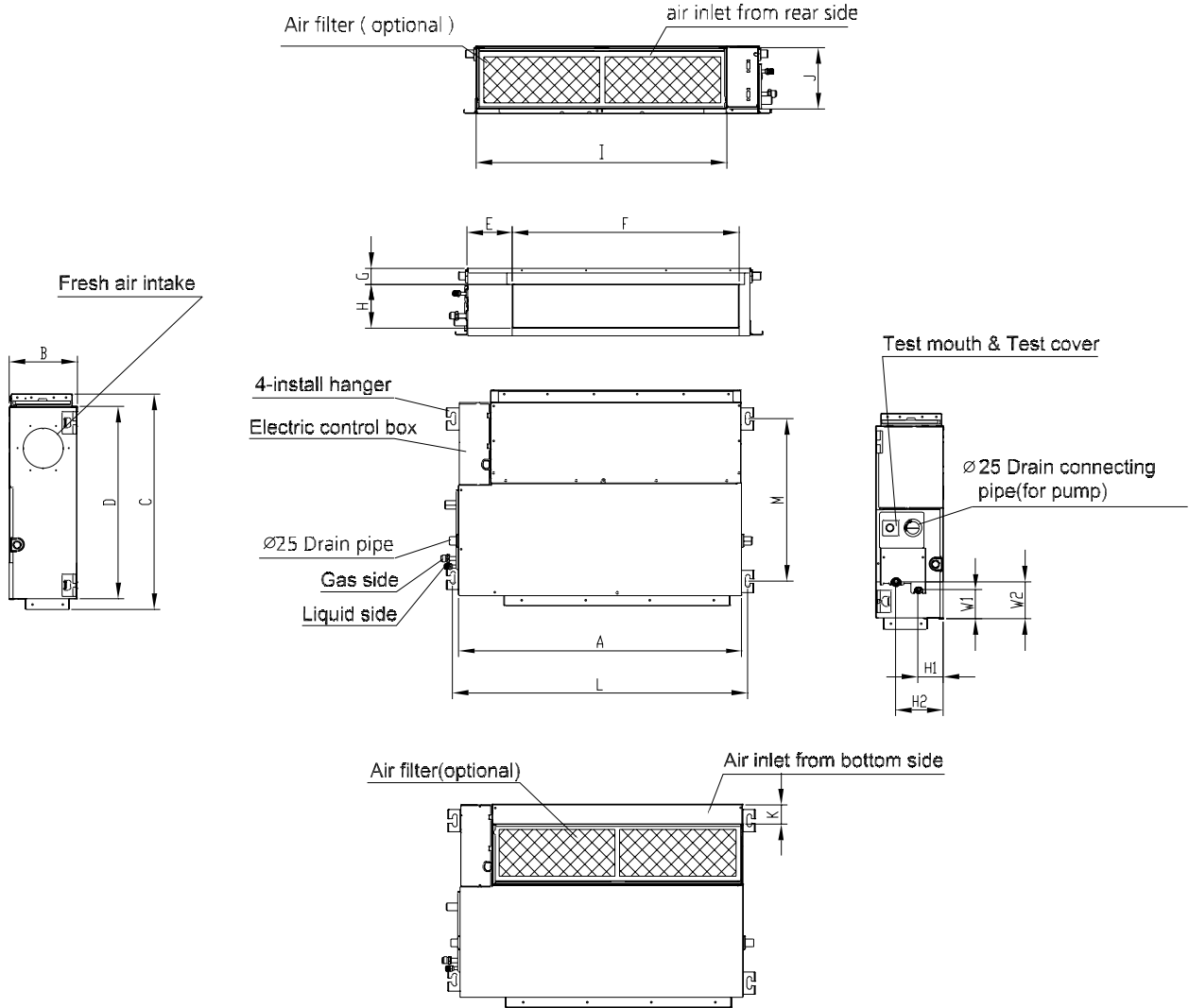

Model	unit	A	B	C	D	E	F	G	H	I	J	K	L	M	H1	H2	W1	W2
(KBtu/h)																		
9/12	mm	700	200	506	450	137	537	30	152	599	186	50	741	360	84	140	84	84
	inch	27.56	7.87	19.92	17.72	5.39	21.14	1.18	5.98	23.58	7.32	1.97	29.17	14.17	3.31	5.51	3.31	3.31
18	mm	880	210	674	600	140	706	50	136	782	190	40	920	508	78	148	88	112
	inch	34.65	8.27	26.54	23.62	5.51	27.8	1.97	5.35	30.79	7.48	1.57	36.22	20	3.07	5.83	3.46	4.41
24	mm	1100	249	774	700	140	926	50	175	1001	228	5	1140	598	80	150	130	155
	inch	43.31	9.80	30.47	27.56	5.51	36.46	1.97	6.89	39.41	8.98	0.2	44.88	23.54	3.15	5.91	5.12	6.10
36	mm	1360	249	774	700	140	1186	50	175	1261	228	5	1400	598	80	150	130	155
	inch	53.54	9.80	30.47	27.56	5.51	46.69	1.97	6.89	49.65	8.98	0.2	55.12	23.54	3.15	5.91	5.12	6.10
48	mm	1200	300	874	800	123	1044	50	227	1101	280	5	1240	697	80	150	185	210
	inch	47.24	11.81	34.41	31.5	4.84	41.1	1.97	8.94	43.35	11.02	0.2	48.82	27.44	3.15	5.91	7.28	8.27

High Static Pressure Duct

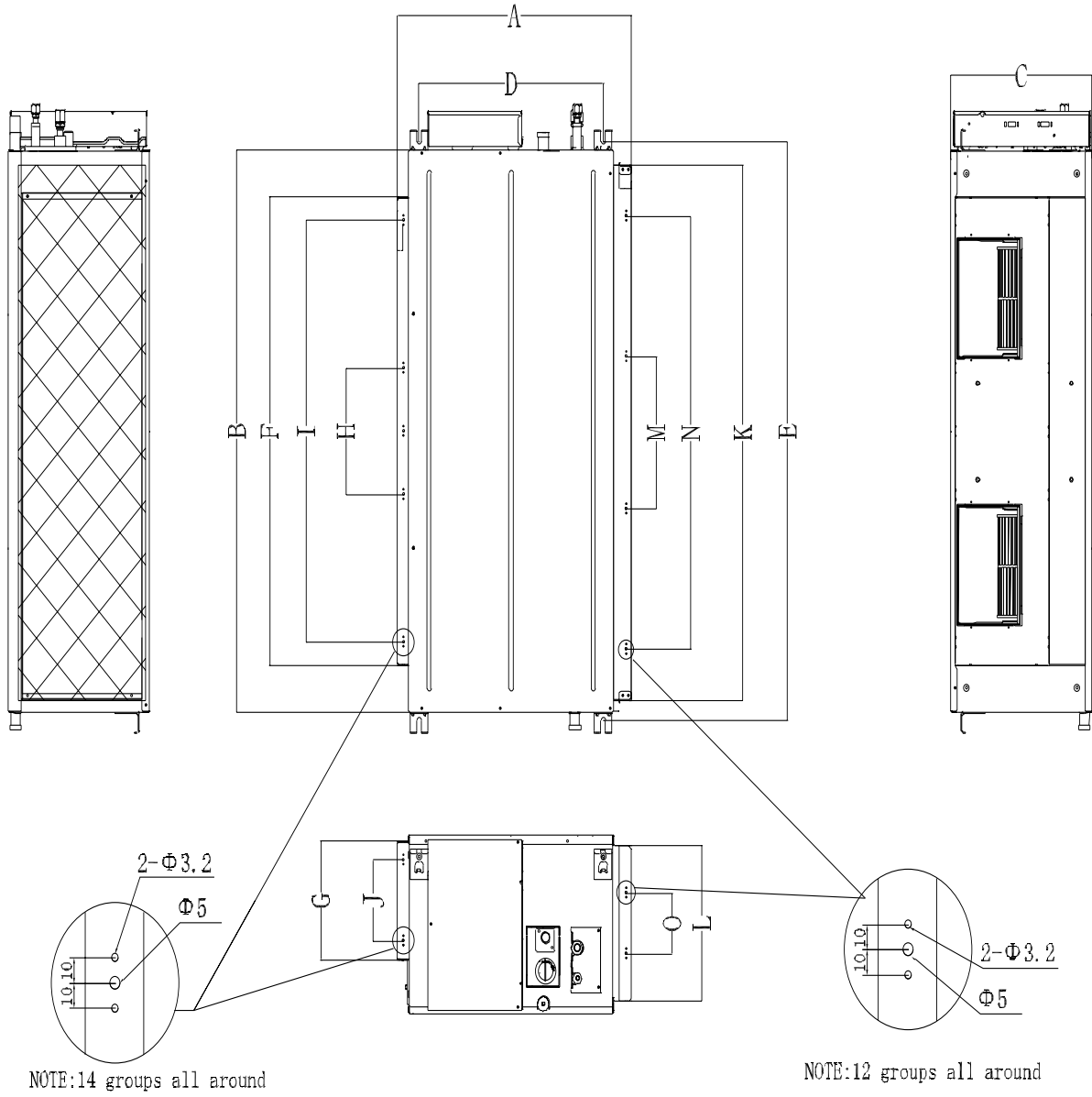

model (KBtu/h)	unit	Outline dimension			Size of mounted lug		Air outlet opening size(symmetry of air outlet opening)					Air inlet opening size(symmetry of air inlet opening)				
		A	B	C	D	E	F	G	H	I	J	K	L	M	N	O
60	mm	858	1400	440	700	1436	1188	385	500	1000	280	1188	325	500	1000	280
	inch	33.8	55.1	17.3	27.5	56.5	46.7	15	20	39.3	11	46.7	12.8	20	39.3	11

3.2 Outdoor Unit

Single Fan Outdoor Unit

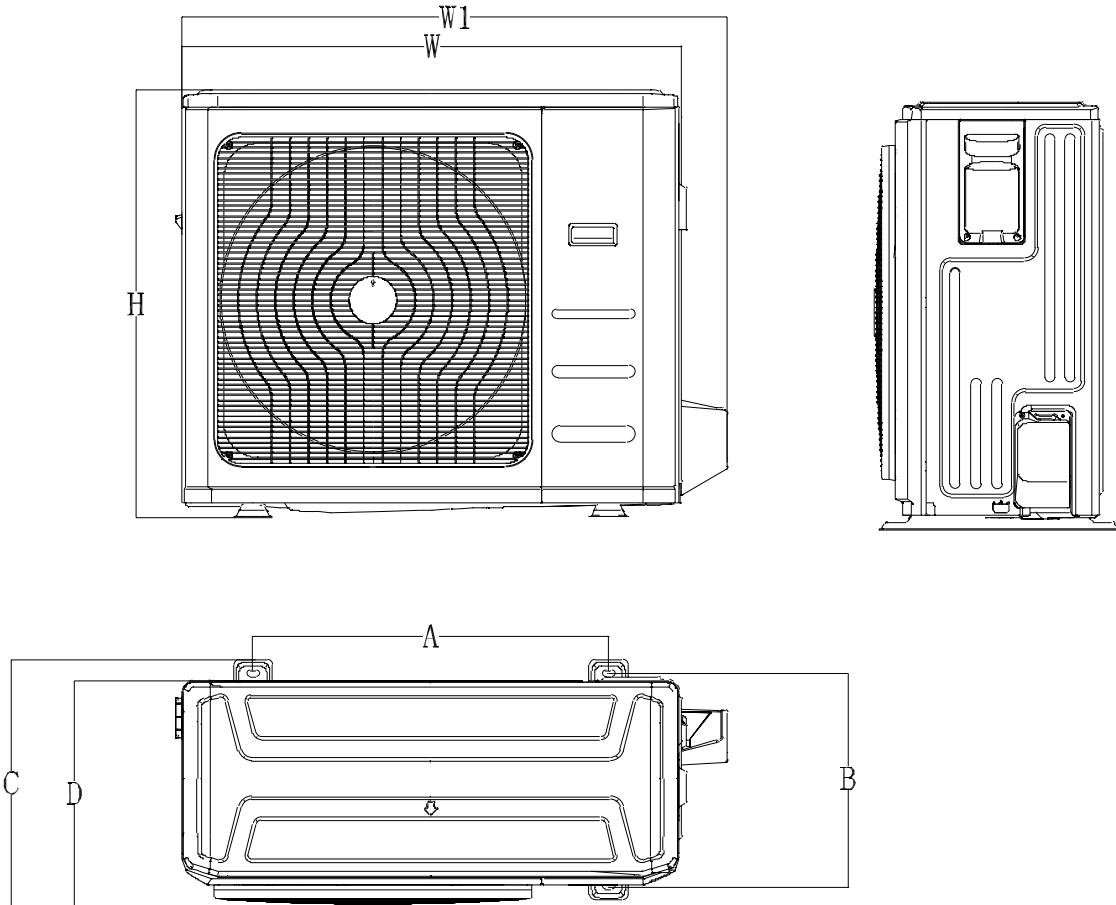

Model	unit	W	D	H	W1	A	B	C
MOBA30-09HFN1-MT0W	mm	770	300	555	840	487	298	322
	inch	30.3	11.8	21.9	33.1	19.2	11.7	12.7
MOB30-12HFN1-MT0W	mm	800	333	554	870	514	340	365
	inch	31.49	13.11	21.81	34.25	20.23	13.39	14.4
MOCA31-18HFN1-MT0W	mm	845	363	702	914	540	350	375
	inch	33.27	14.29	27.64	35.98	21.26	13.78	14.8
MOD31-24HFN1-MT0W	mm	946	410	810	1030	673	403	455
	inch	37.24	16.14	31.89	40.55	26.50	15.87	17.9
MOD30U-36HFN1-M	mm	946	410	810	1030	673	403	455
	inch	37.24	16.14	31.89	40.55	26.50	15.87	17.9

Double Fan Outdoor Unit

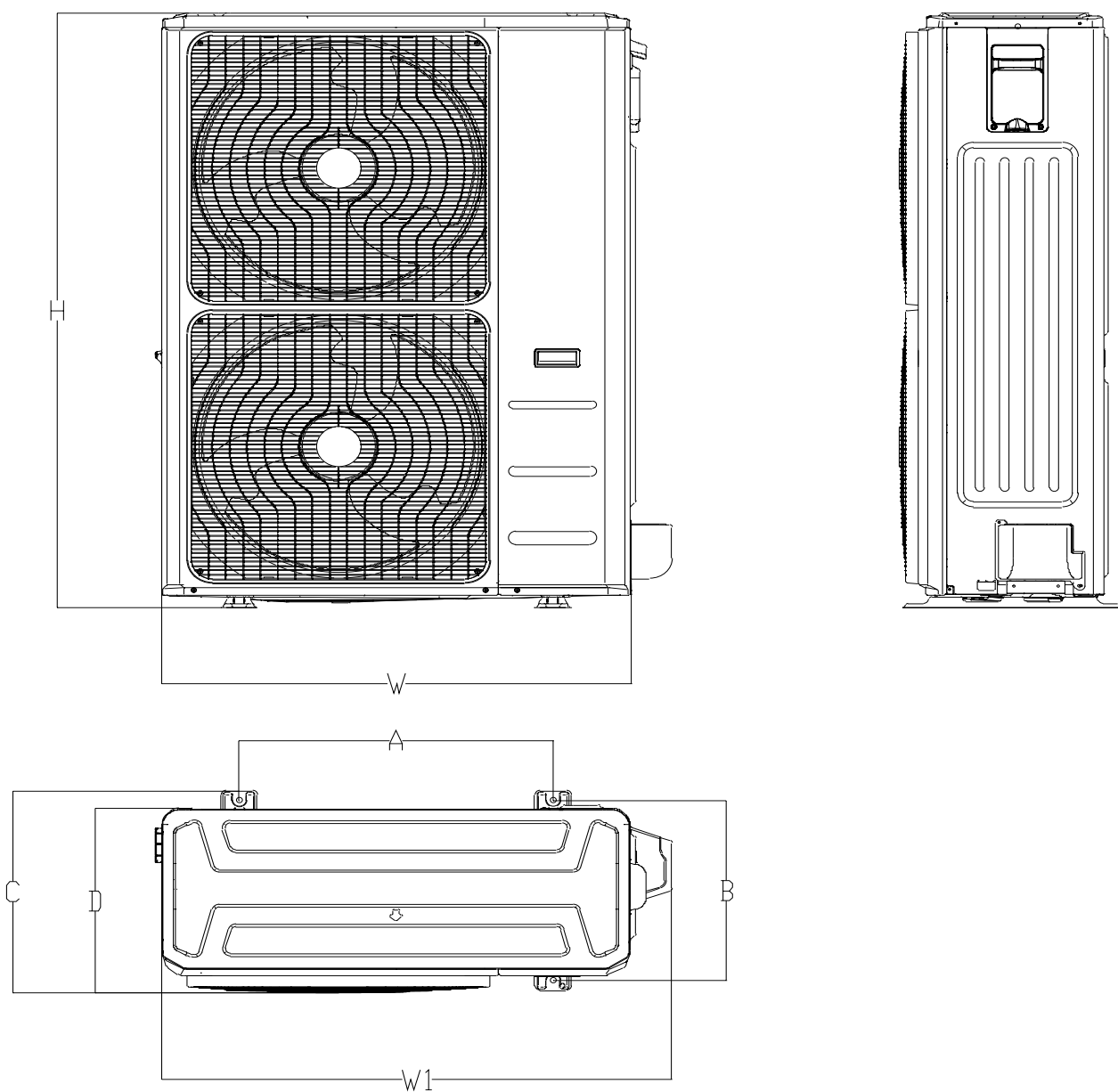

Specifications

Model	unit	W	D	H	W1	A	B	C
MOE30U-48HFN1-M	mm	952	415	1333	1045	634	404	457
	inch	37.5	16.3	52.5	41.1	25	15.9	18
MOE30U-60HFN1-M	mm	952	415	1333	1045	634	404	457
	inch	37.5	16.3	52.5	41.1	25	15.9	18

4. Centre of gravity

MOBA30-09HFN1-MT0W

Specifications

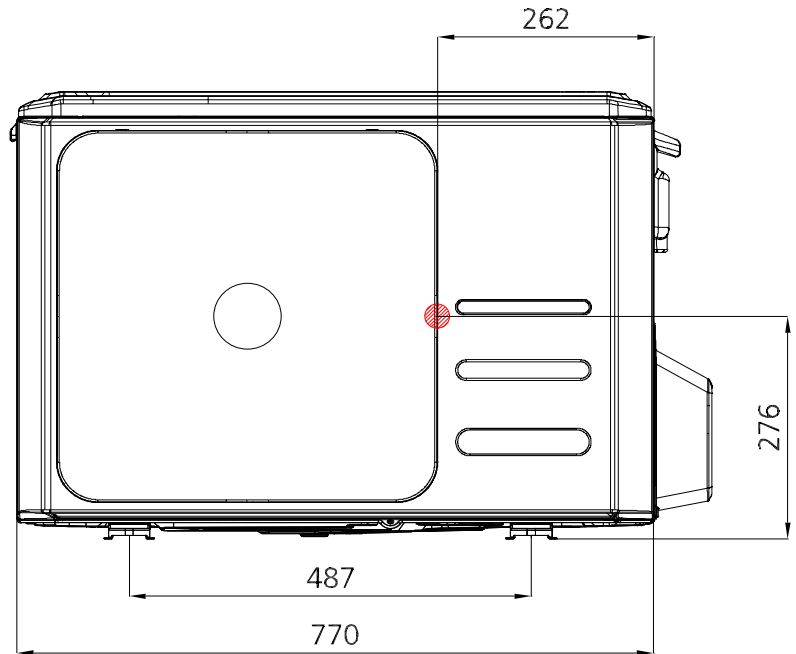
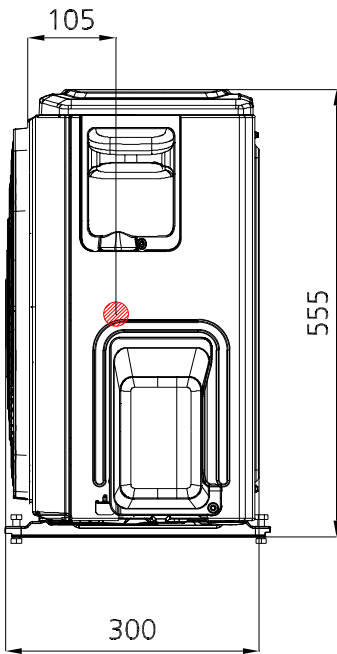

MOB30-12HFN1-MT0W

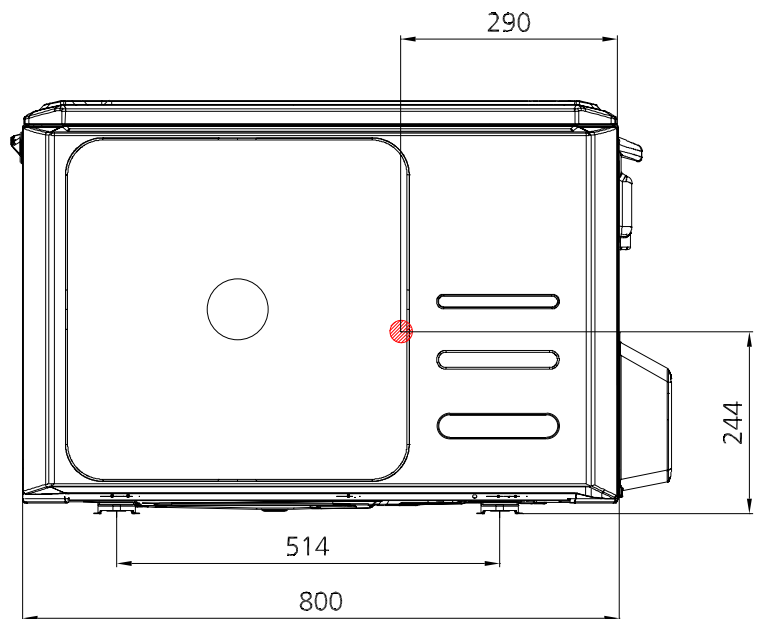
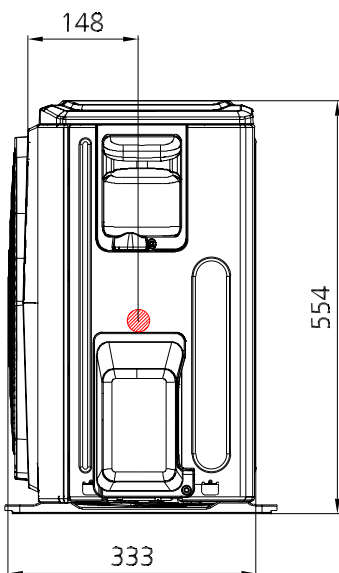

MOCA31-18HFN1-MT0W

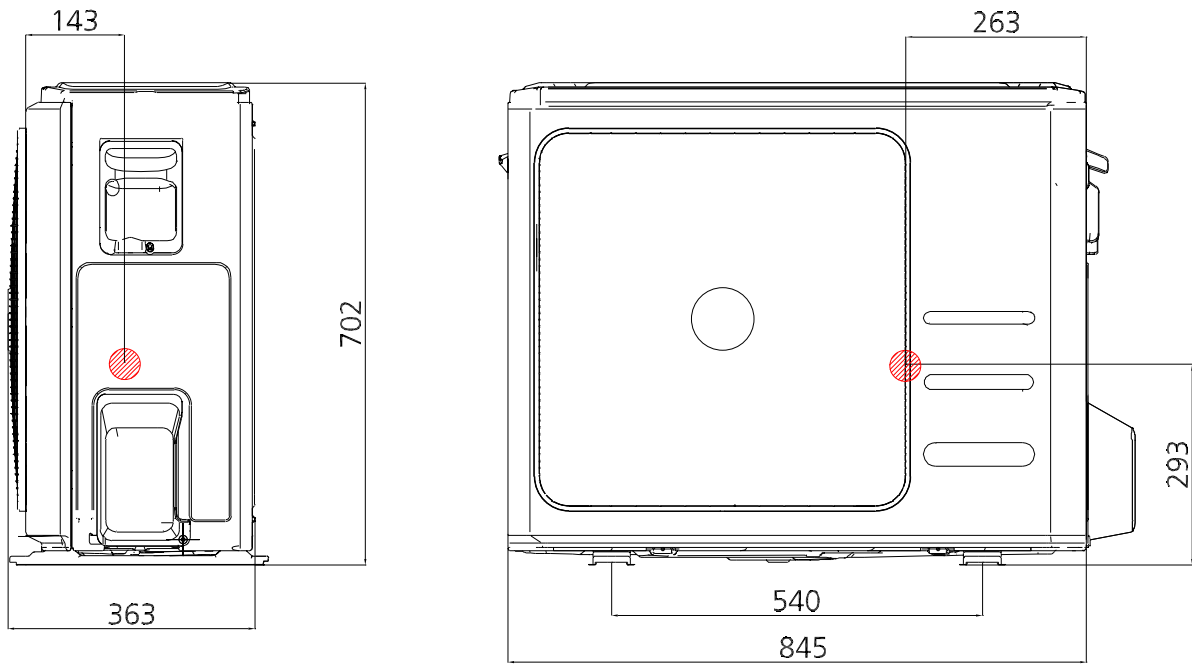

MOD31-24HFN1-MT0W, MOD30U-36HFN1-M

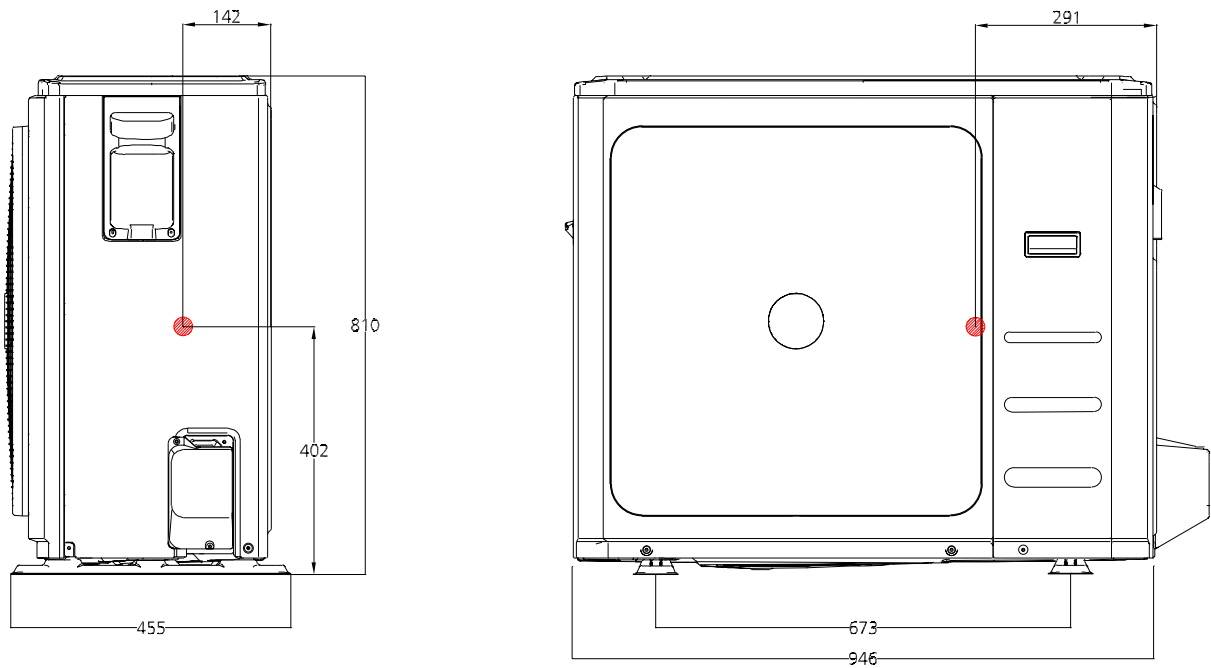

MOE30U-48HFN1-M, MOE30U-60HFN1-M

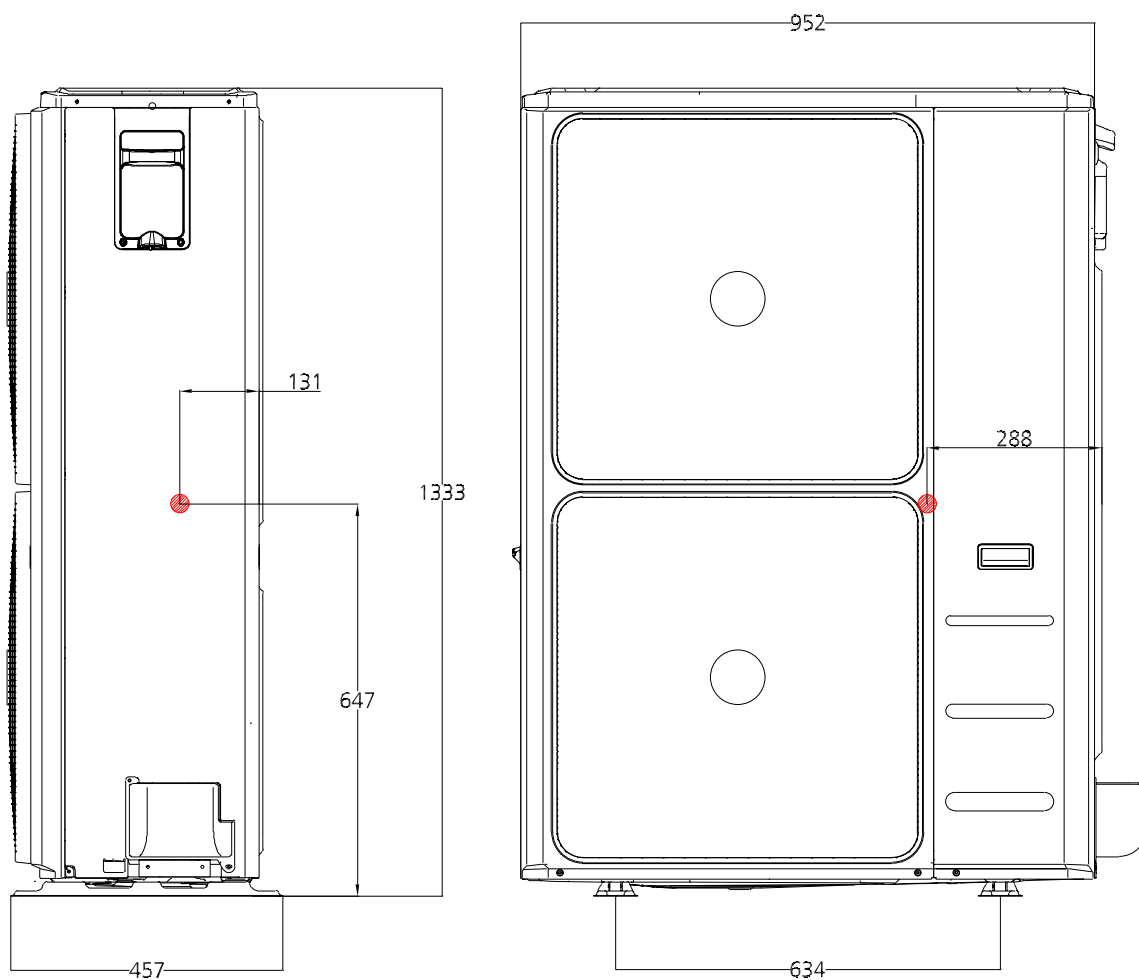

5. Electrical Wiring Diagrams

5.1 Indoor unit

Abbreviation	Paraphrase
Y/G	Yellow-Green Conductor
CAP1	Indoor Fan Capacitor
FAN	Indoor Fan
PUMP	PUMP
L	LIVE
N	NEUTRAL
TO CCM Comm.Bus	Central Controller
T1	Indoor Room Temperature
T2	Coil Temperature of Indoor Heat Exchanger
P1	Super High Speed
P2	High Speed

MTIU-09HWFN1-M, MTIU-12HWFN1-M, MTIU-18HWFN1-M, MTIU-24HWFN1-M

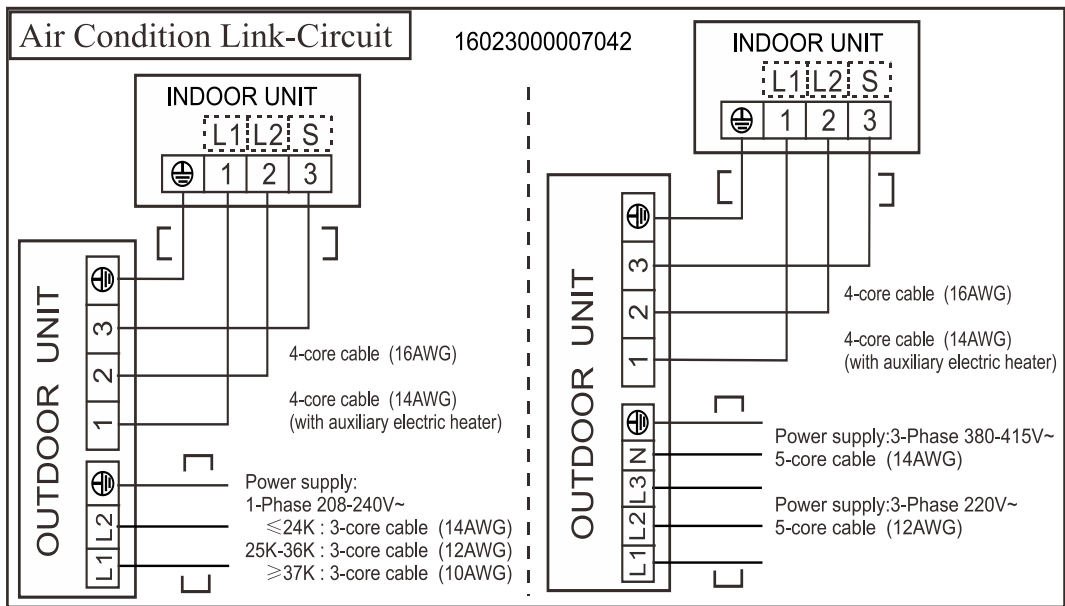
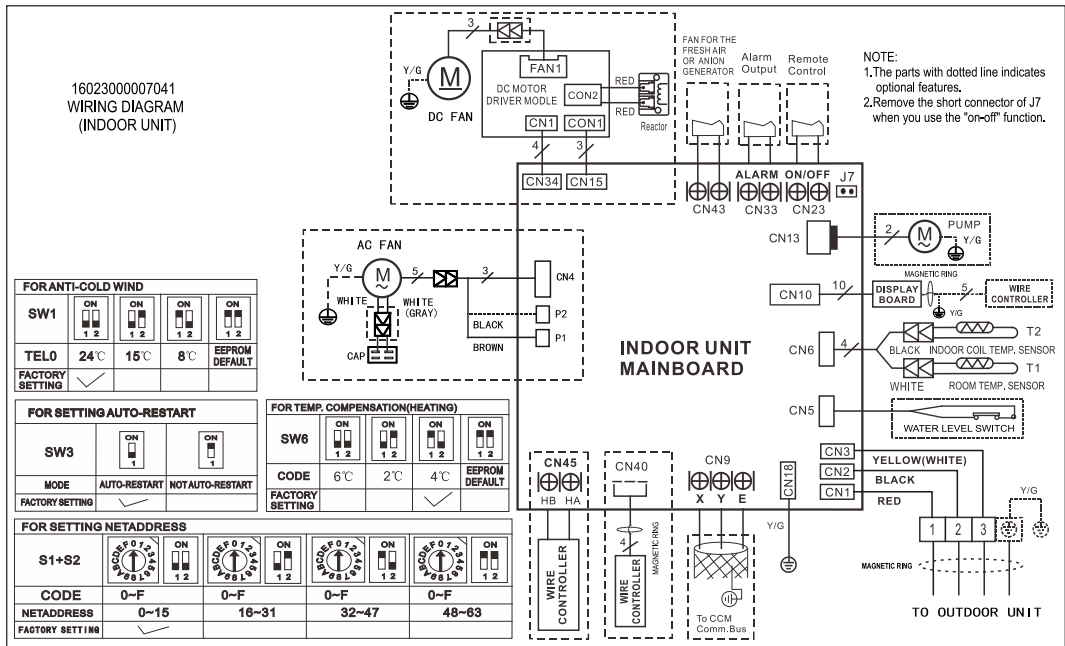

MTI-36HWFN1-M, MTI-48HWFN1-M, MHG-60HWFN1-MW

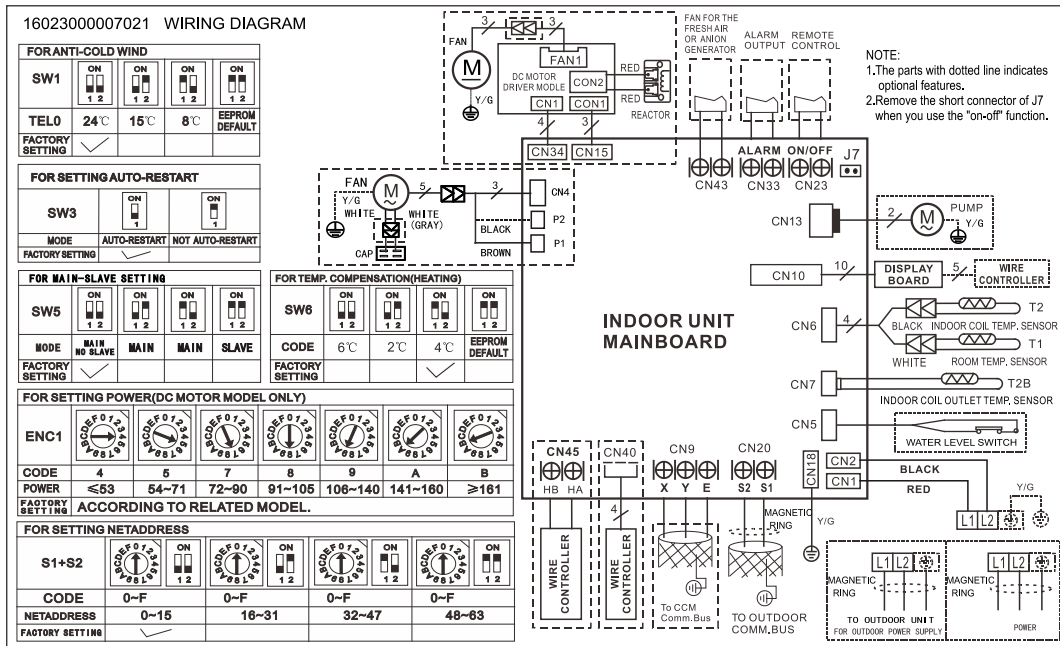

Specifications

MTI-36HWFN1-M, MTI-48HWFN1-M

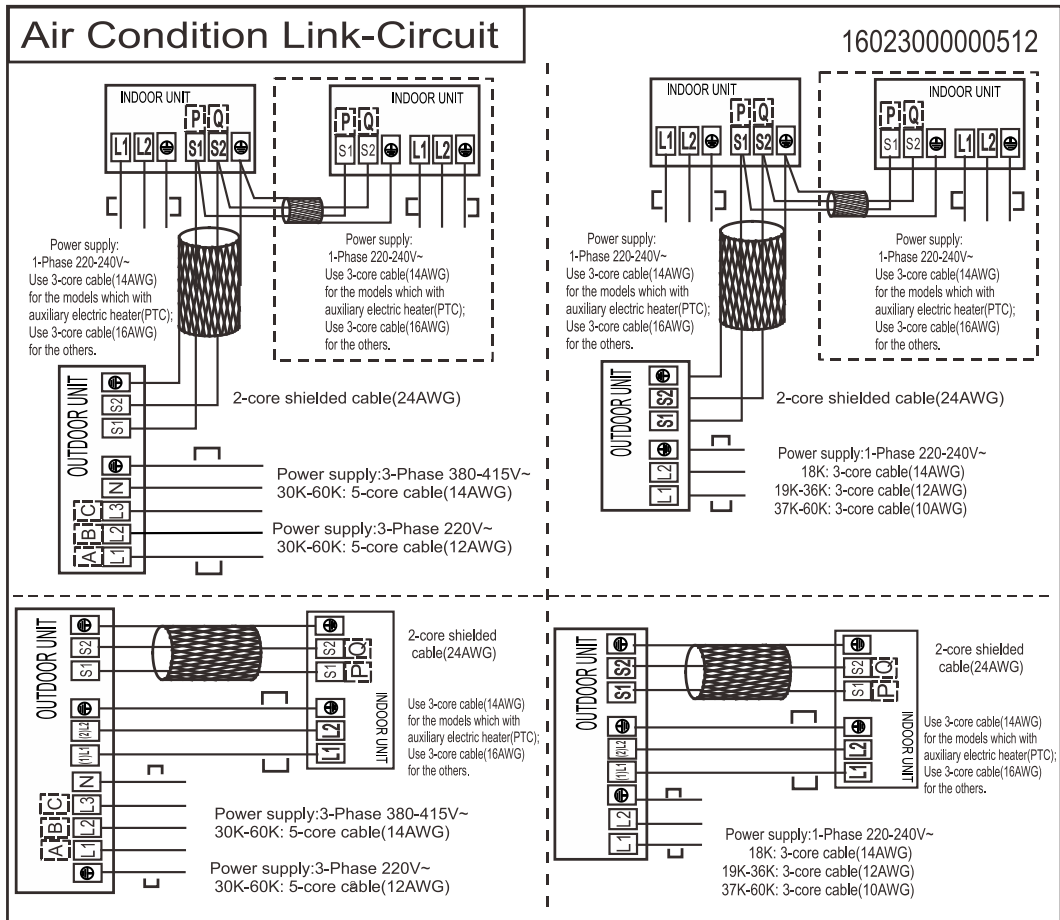

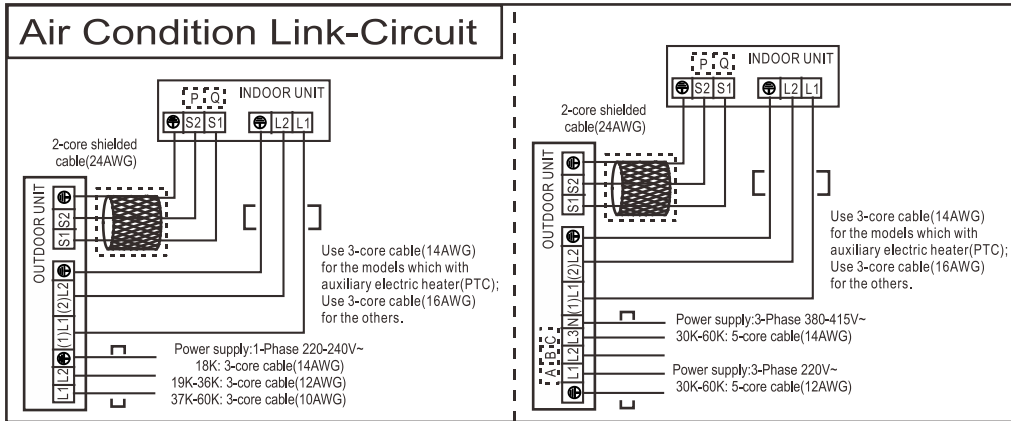

5.2 Some connectors introduce:

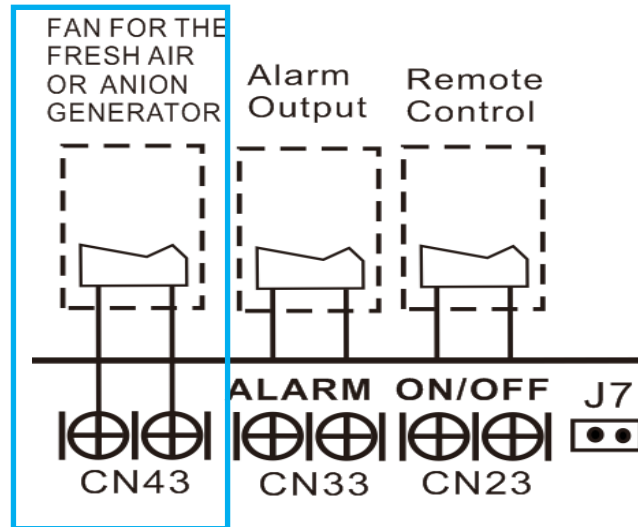

A. For new fresh motor terminal port (also for Anion generator) CN43:

1. Connect the fan motor to the port , no need care L/N of the motor ;
2. The output voltage is the power supply;
3. The fresh motor can not exceed 200W or 1A , follow the smaller one ;
4. The new fresh motor will be worked when the indoor fan motor work ;when the indoor fan motor stops , the new fresh motor would be stopped ;
5. When the unit enter force cooling mode or capacity testing mode , the fresh motor isn't work .

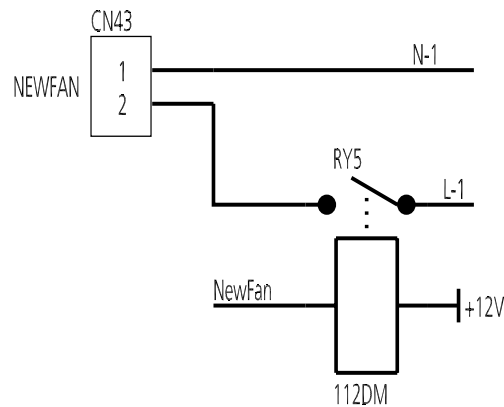

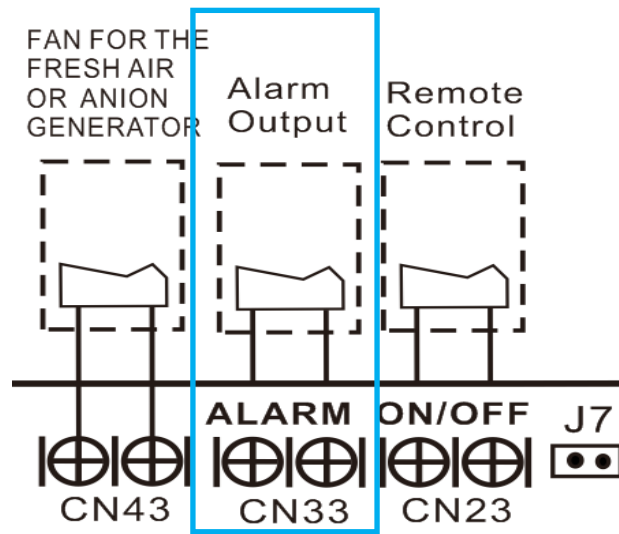

B For ALARM terminal port CN33

1. Provide the terminal port to connect ALARM ,but no voltage of the terminal port , the power from the ALARM system (not from the unit)
2. Although design voltage can support higher voltage ,but we strongly ask you connect the power less than 24V, current less than 0.5A
3. When the unit occurs the problem , the relay would be closed , then ALARM works

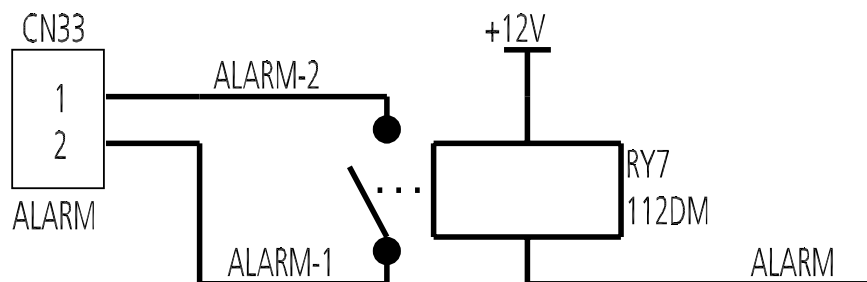

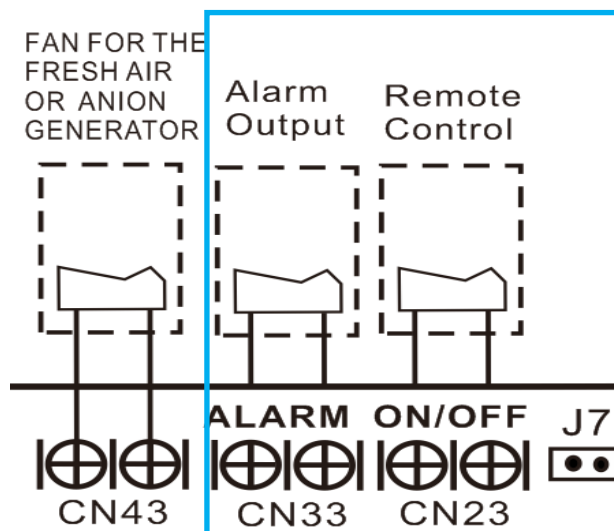

C. For remote control (ON-OFF) terminal port CN23 and short connector of J7

1. Remove the short connector of J7 when you use ON-OFF function;
2. When remote switch off (OPEN) ;the unit would be off;
3. When remote switch on (CLOSE) ;the unit would be on;
4. When close/open the remote switch, the unit would be responded the demand within 2 seconds;
5. When the remote switch on . you can use remote controller/ wire controller to select the mode what you want ;when the remote switch off , the unit would not respond the demand from remote controller/wire controller.

when the remote switch off , but the remote controller / wire controller are on, CP code would be shown on the display board.

6.The voltage of the port is 12V DC , design Max.current is 5mA.

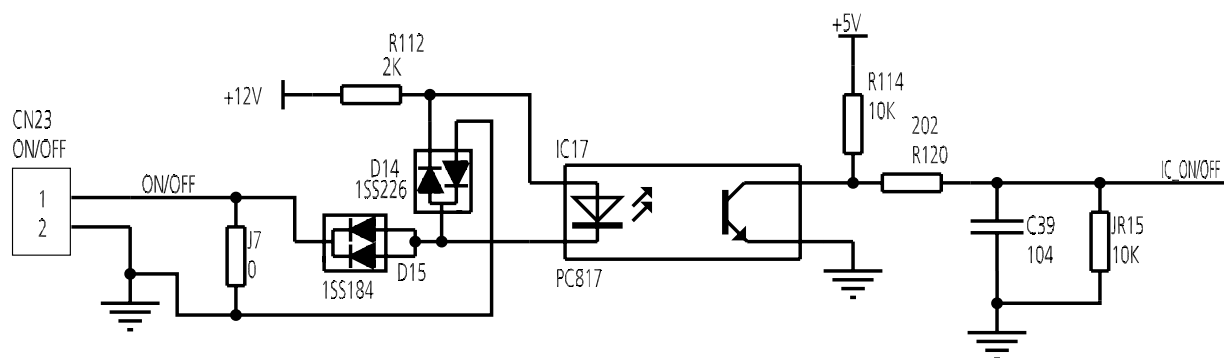

5.3 Outdoor Unit

Abbreviation	Paraphrase
CAP1, CAP2, CAP3,CAP4	Capacitor
FAN1	Outdoor Fan Motor
KM8	Contactora
CT1, CT2	AC Current Detector
COMP	Compressor
L-PRO, K2	Low Pressure Switch/Shorting Stub
K1	High Pressure Switch/Shorting Stub
TRANS	Power Transformer
T4	10KΩ RESISTANCE/Outdoor Ambient Temperature
T3	10KΩ RESISTANCE/Coil Temperature of Condenser
XT1	2-Way Terminal/4-Way Terminal
XT2	3-Way Terminal
XT4	Terminal
K3	Compressor Discharge Temperature/Shorting Stub
XP1~XP5,XT5~XT7	Connectors

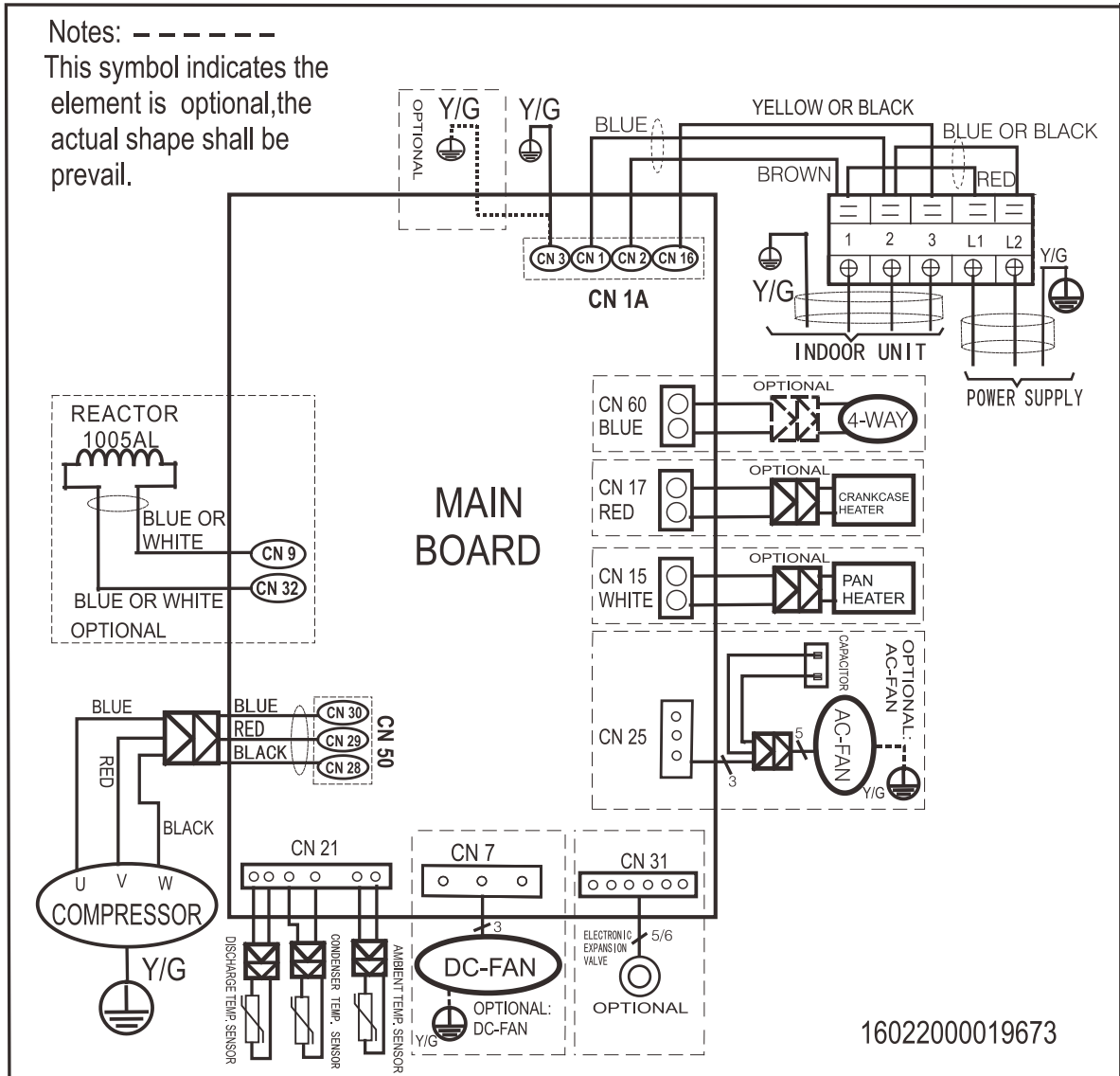

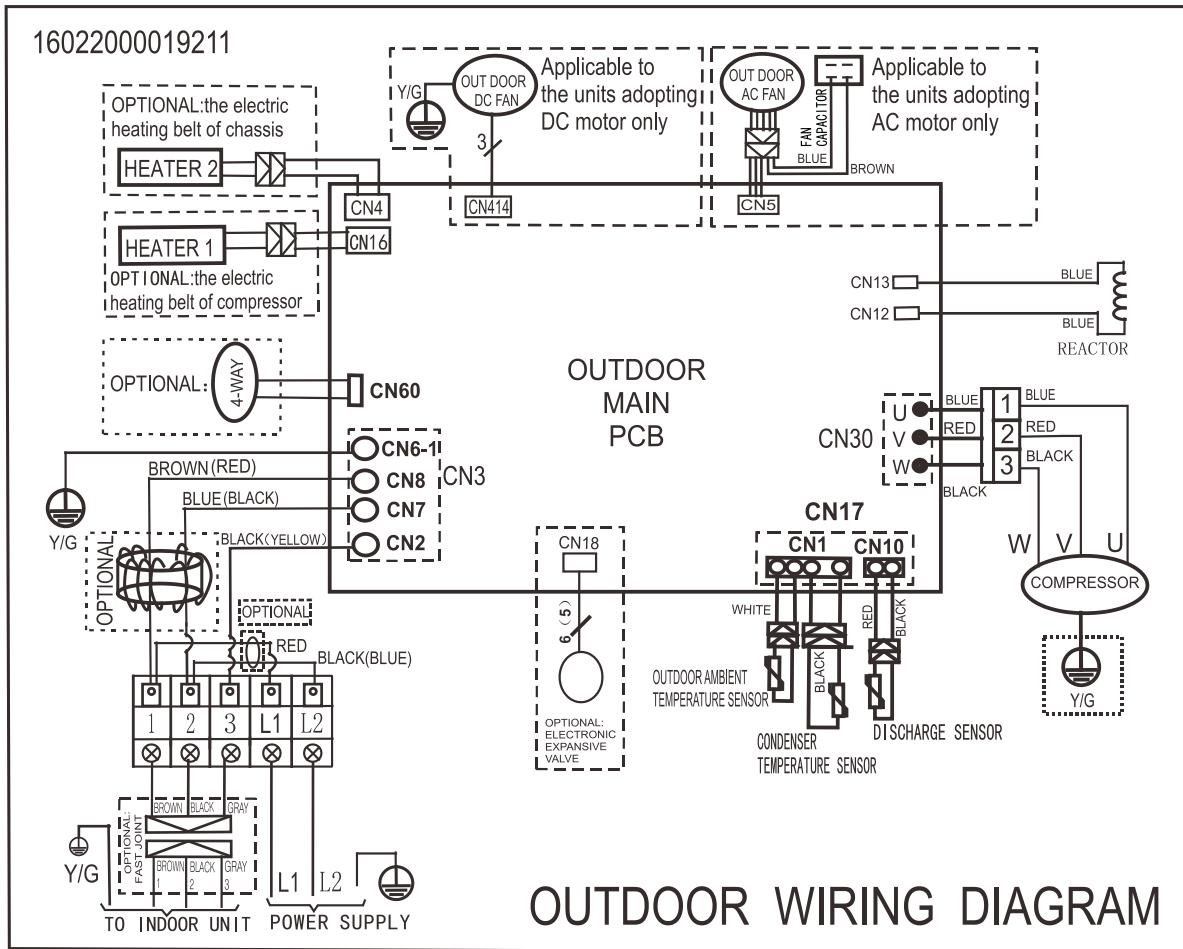

MOD30U-36HFN1-M

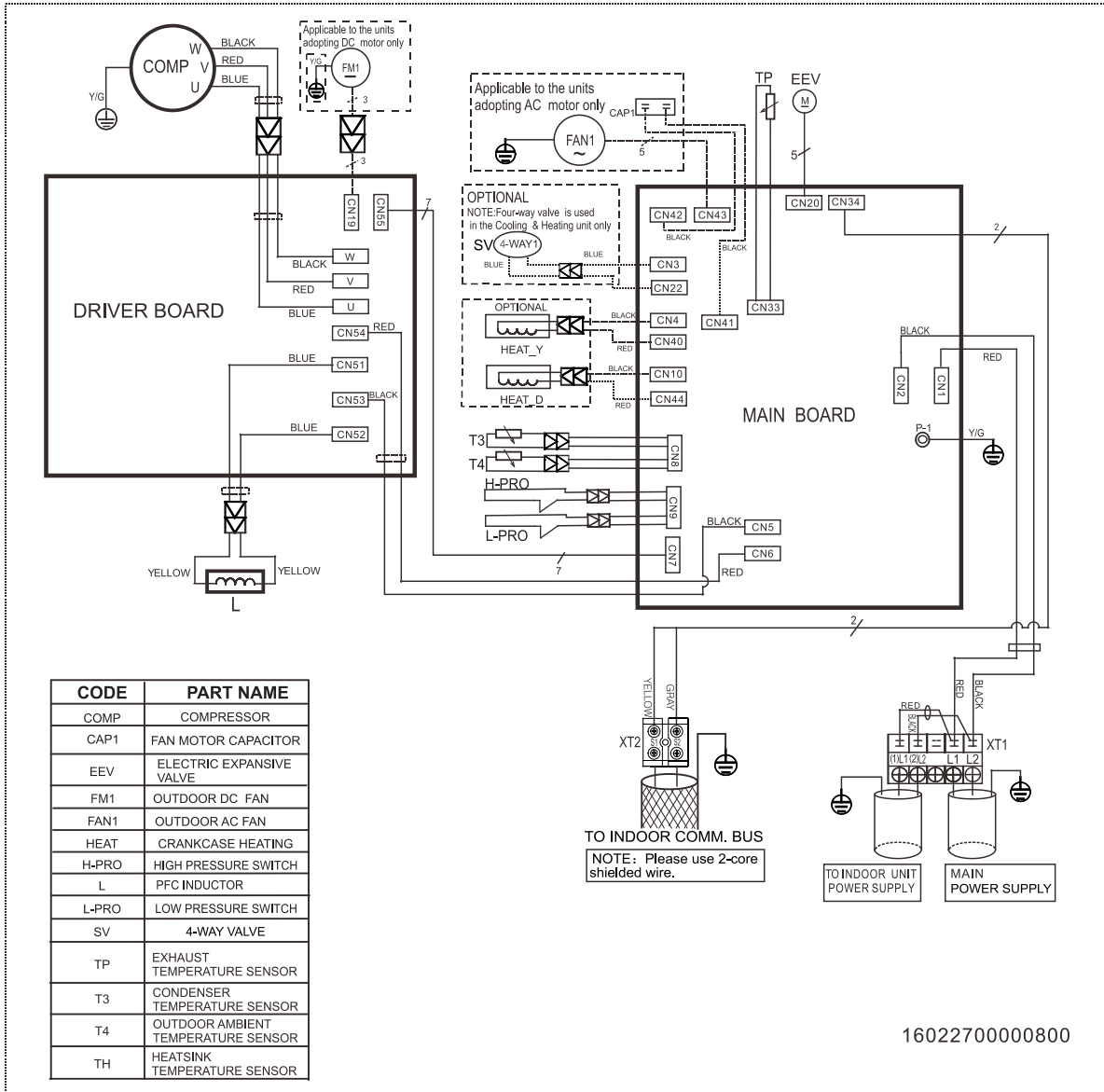

Specifications

1602270000800

MOE30U-48HFN1-M, MOE30U-60HFN1-M

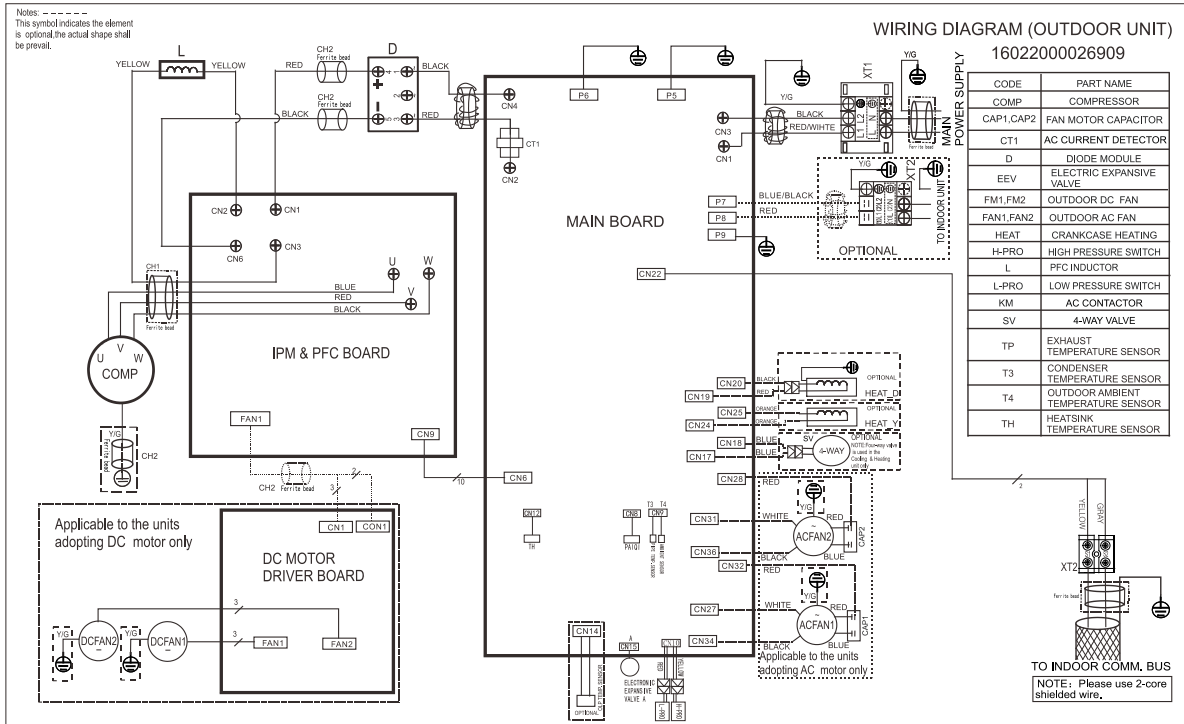

6. Refrigerant Cycle Diagrams

6.1 Heat pump

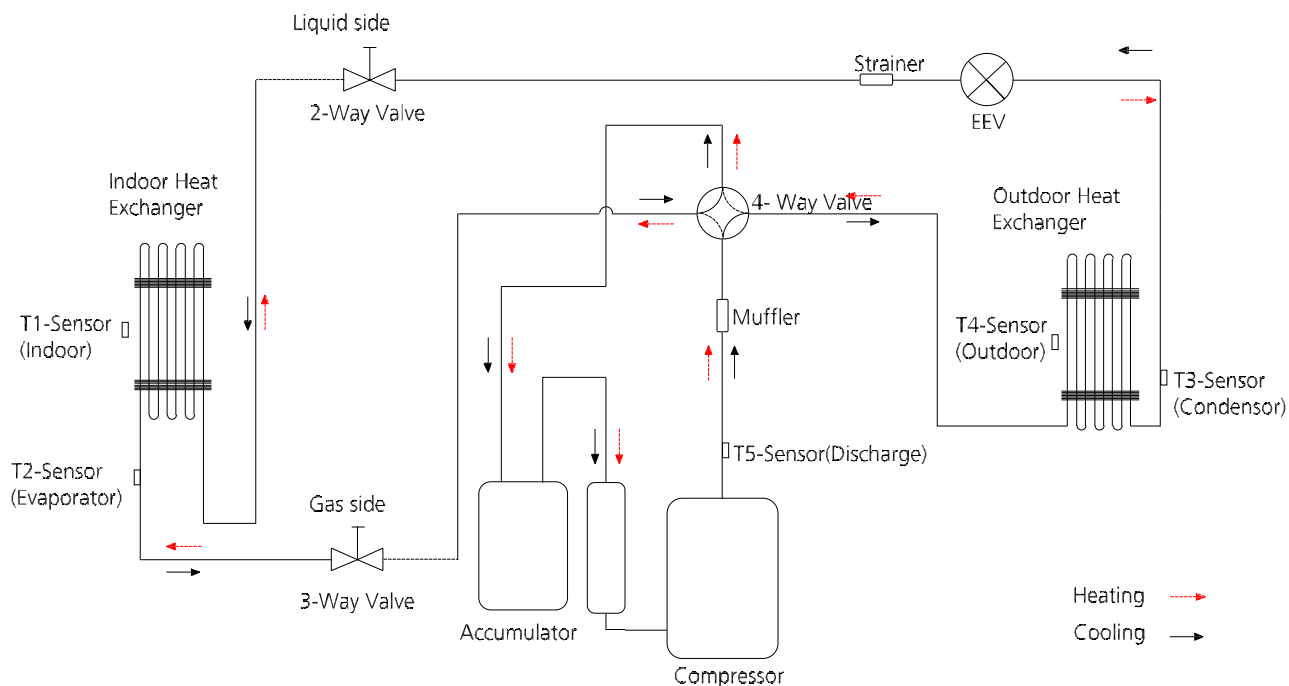

Model No.	Pipe Size (Diameter:Ø) inch		Piping length (m/ft)		Elevation (m/ft)		Additional Refrigerant
	Gas	Liquid	Rated	Max.	Rated	Max.	
MOBA30-09HFN1-MTOW	3/8	1/4	7.5/24.6	25/82	0	10/32.8	15g/m (0.16oz/ft)
MOB30-12HFN1-MTOW	1/2	1/4	7.5/24.6	25/82	0	10/32.8	15g/m (0.16oz/ft)

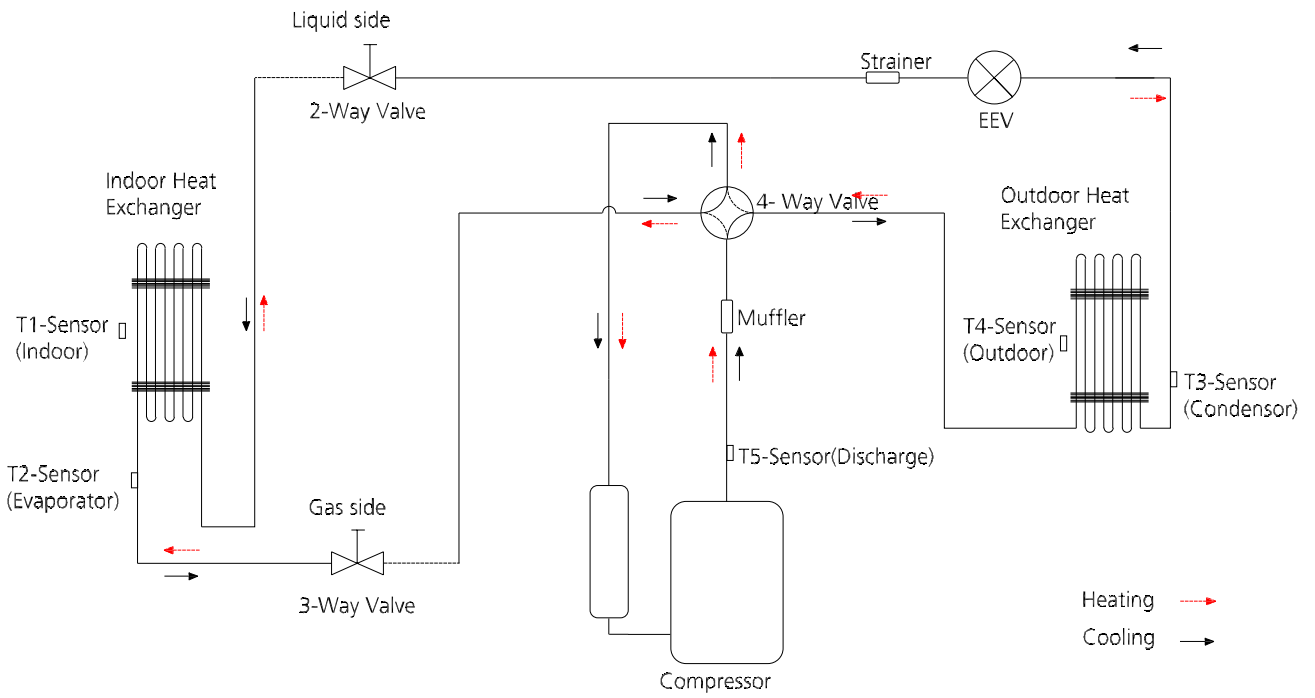

Model No.	Pipe Size (Diameter:Ø) inch		Piping length (m/ft)		Elevation (m/ft)		Additional Refrigerant
	Gas	Liquid	Rated	Max.	Rated	Max.	
MOCA31-18HFN1-MT0W	1/2	1/4	7.5/24.6	30/98	0	20/65.6	15g/m (0.16oz/ft)
MOD31-24HFN1-MT0W	5/8	3/8	7.5/24.6	50/164	0	25/82	30g/m (0.32oz/ft)

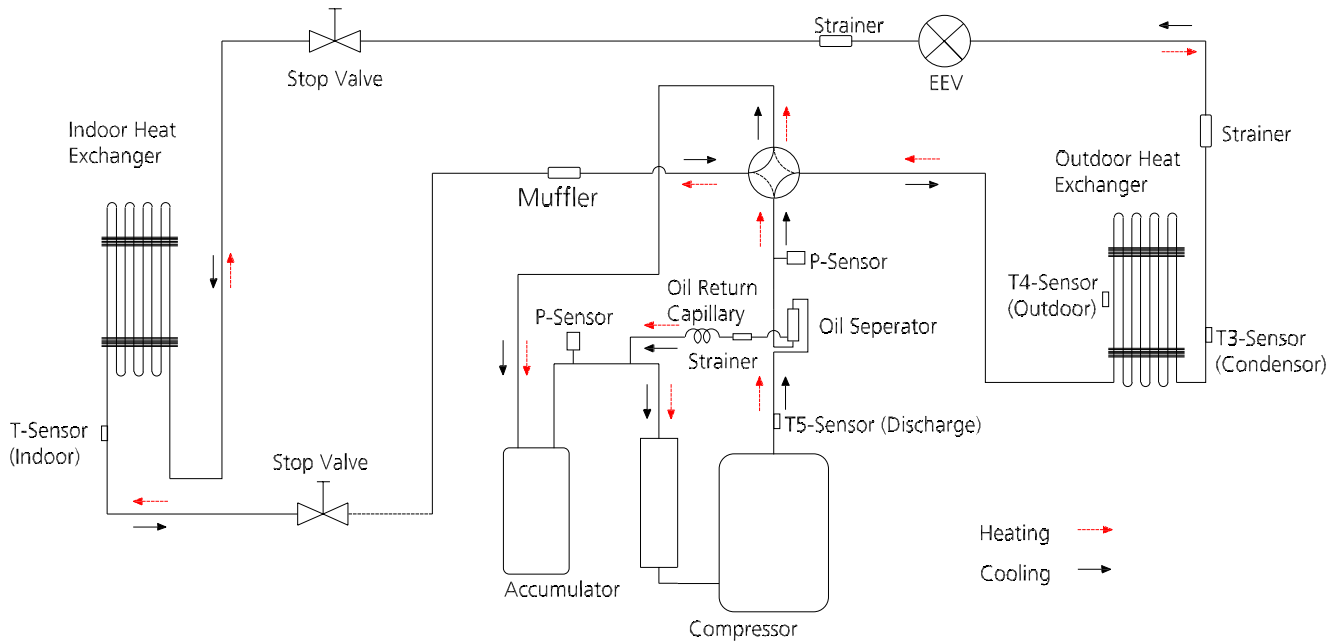

Model No.	Pipe Size (Diameter:ø) inch		Piping length (m/ft)		Elevation (m/ft)		Additional Refrigerant
	Gas	Liquid	Rated	Max.	Rated	Max.	
MOD30U-36HFN1-M	5/8	3/8	7.5/24.6	65/213.3	0	30/98.4	30g/m (0.32oz/ft)
MOE30U-48HFN1-M	5/8	3/8	7.5/24.6	65/213.3	0	30/98.4	30g/m (0.32oz/ft)
MOE30U-60HFN1-M	3/4	3/8	7.5/24.6	65/213.3	0	30/98.4	30g/m (0.32oz/ft)

7. Capacity Correction Factor for Height Difference

Model	9K		Pipe Length (m)			
Cooling			7.5	10	20	25
Height difference H (m)	Indoor Upper than Outdoor	/	/	/	/	/
		10	0.976	0.954	0.944	
	Outdoor Upper than Indoor	5	0.996	0.986	0.963	0.953
		0	1.000	0.990	0.968	0.957
	Outdoor Upper than Indoor	-5	1.000	0.990	0.968	0.957
		-10	/	0.990	0.968	0.957
			/	/	/	/
Heating			7.5	10	20	25
Height difference H (m)	Indoor Upper than Outdoor	/	/	/	/	/
		10	0.994	0.981	0.974	
	Outdoor Upper than Indoor	5	1.000	0.994	0.981	0.974
		0	1.000	0.994	0.981	0.974
	Outdoor Upper than Indoor	-5	0.992	0.986	0.973	0.966
		-10	/	0.978	0.965	0.958
			/	/	/	/

Model	12K		Pipe Length (m)			
Cooling			7.5	10	20	25
Height difference H (m)	Indoor Upper than Outdoor	/	/	/	/	/
		10	0.974	0.953	0.942	
	Outdoor Upper than Indoor	5	0.995	0.984	0.962	0.951
		0	1.000	0.989	0.967	0.956
	Outdoor Upper than Indoor	-5	1.000	0.989	0.967	0.956
		-10	/	0.989	0.967	0.956
			/	/	/	/
Heating			7.5	10	20	25
Height difference H (m)	Indoor Upper than Outdoor	/	/	/	/	/
		10	0.994	0.981	0.974	
	Outdoor Upper than Indoor	5	1.000	0.994	0.981	0.974
		0	1.000	0.994	0.981	0.974
	Outdoor Upper than Indoor	-5	0.992	0.986	0.973	0.966
		-10	/	0.978	0.965	0.958
			/	/	/	/

Model	18K		Pipe Length (m)			
Cooling			5	10	20	30
Height difference H (m)	Indoor Upper than Outdoor	20			0.941	0.919
		10		0.974	0.951	0.928
		5	0.995	0.983	0.960	0.937
		0	1.000	0.988	0.965	0.942
	Outdoor Upper than Indoor	-5	1.000	0.988	0.965	0.942
		-10		0.988	0.965	0.942
		-20			0.965	0.942
Heating			5	10	20	30
Height difference H (m)	Indoor Upper than Outdoor	20			0.987	0.978
		10		0.996	0.987	0.978
		5	1.000	0.996	0.987	0.978
		0	1.000	0.996	0.987	0.978
	Outdoor Upper than Indoor	-5	0.992	0.988	0.979	0.970
		-10		0.980	0.971	0.962
		-20			0.963	0.955

Model	24K		Pipe Length (m)					
Cooling			5	10	20	30	40	50
Height difference H (m)	Indoor Upper than Outdoor	25				0.917	0.898	0.879
		20			0.946	0.926	0.907	0.887
		10		0.975	0.955	0.936	0.916	0.896
		5	0.995	0.985	0.965	0.945	0.925	0.905
	Outdoor Upper than Indoor	0	1.000	0.990	0.970	0.950	0.930	0.910
		-5	1.000	0.990	0.970	0.950	0.930	0.910
		-10		0.990	0.970	0.950	0.930	0.910
		-20			0.970	0.950	0.930	0.910
		-25				0.950	0.930	0.910
Heating			5	10	20	30	40	50
Height difference H (m)	Indoor Upper than Outdoor	25				0.984	0.978	0.972
		20			0.991	0.984	0.978	0.972
		10		0.997	0.991	0.984	0.978	0.972
		5	1.000	0.997	0.991	0.984	0.978	0.972
	Outdoor Upper than Indoor	0	1.000	0.997	0.991	0.984	0.978	0.972
		-5	0.992	0.989	0.983	0.977	0.970	0.964
		-10		0.981	0.975	0.969	0.963	0.957
		-20			0.967	0.961	0.955	0.949
		-25				0.953	0.947	0.941

Model	36K		Pipe Length (m)					
Cooling			5	15	25	35	50	65
Height difference H (m)	Indoor Upper than Outdoor	30				0.889	0.850	0.812
		20			0.924	0.898	0.859	0.820
		10		0.959	0.933	0.907	0.868	0.828
		5	0.995	0.969	0.942	0.916	0.876	0.837
		0	1.000	0.974	0.947	0.921	0.881	0.841
	Outdoor Upper than Indoor	-5	1.000	0.974	0.947	0.921	0.881	0.841
		-10		0.974	0.947	0.921	0.881	0.841
		-20			0.947	0.921	0.881	0.841
		-30				0.921	0.881	0.841
		Heating			5	15	25	35
Height difference H (m)	Indoor Upper than Outdoor	30				0.964	0.945	0.927
		20			0.976	0.964	0.945	0.927
		10		0.988	0.976	0.964	0.945	0.927
		5	1.000	0.988	0.976	0.964	0.945	0.927
		0	1.000	0.988	0.976	0.964	0.945	0.927
	Outdoor Upper than Indoor	-5	0.992	0.980	0.968	0.956	0.938	0.920
		-10		0.972	0.960	0.948	0.930	0.912
		-20			0.952	0.941	0.923	0.905
		-30				0.933	0.915	0.898

Model	48K		Pipe Length (m)					
Cooling			5	15	25	35	50	65
Height difference H (m)	Indoor Upper than Outdoor	30				0.884	0.843	0.802
		20			0.920	0.893	0.852	0.810
		10		0.957	0.930	0.902	0.860	0.819
		5	0.995	0.967	0.939	0.911	0.869	0.827
	Outdoor Upper than Indoor	0	1.000	0.972	0.944	0.916	0.873	0.831
		-5	1.000	0.972	0.944	0.916	0.873	0.831
		-10		0.972	0.944	0.916	0.873	0.831
		-20			0.944	0.916	0.873	0.831
		-30				0.916	0.873	0.831
Heating			5	15	25	35	50	65
Height difference H (m)	Indoor Upper than Outdoor	30				0.958	0.936	0.915
		20			0.972	0.958	0.936	0.915
		10		0.986	0.972	0.958	0.936	0.915
		5	1.000	0.986	0.972	0.958	0.936	0.915
	Outdoor Upper than Indoor	0	1.000	0.986	0.972	0.958	0.936	0.915
		-5	0.992	0.978	0.964	0.950	0.929	0.908
		-10		0.970	0.956	0.942	0.921	0.900
		-20			0.949	0.935	0.914	0.893
		-30				0.927	0.907	0.886

Model	60K		Pipe Length (m)					
Cooling			5	15	25	35	50	65
Height difference H (m)	Indoor Upper than Outdoor	30				0.870	0.823	0.775
		20			0.911	0.879	0.831	0.783
		10		0.953	0.920	0.888	0.840	0.791
		5	0.995	0.962	0.930	0.897	0.848	0.799
		0	1.000	0.967	0.934	0.902	0.852	0.803
	Outdoor Upper than Indoor	-5	1.000	0.967	0.934	0.902	0.852	0.803
		-10		0.967	0.934	0.902	0.852	0.803
		-20			0.934	0.902	0.852	0.803
		-30				0.902	0.852	0.803
		Heating			5	15	25	35
Height difference H (m)	Indoor Upper than Outdoor	30				0.955	0.932	0.909
		20			0.970	0.955	0.932	0.909
		10		0.985	0.970	0.955	0.932	0.909
		5	1.000	0.985	0.970	0.955	0.932	0.909
		0	1.000	0.985	0.970	0.955	0.932	0.909
	Outdoor Upper than Indoor	-5	0.992	0.977	0.962	0.947	0.924	0.902
		-10		0.969	0.954	0.939	0.917	0.895
		-20			0.947	0.932	0.910	0.887
		-30				0.924	0.902	0.880

8. Noise Criterion Curves

8.1 Indoor Unit

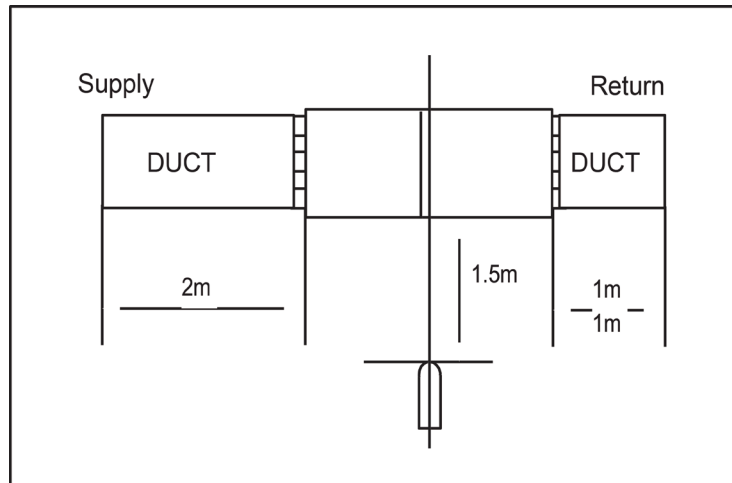

Notes:

- Sound measured at 1.5m away from the center of the unit.
- Data is valid at free field condition
- Data is valid at nominal operation condition
- Reference acoustic pressure $OdB = 20\mu Pa$
- Sound level will vary depending on a range of factors such as the construction -(acoustic absorption coefficient) of particular room in which the equipment is installed.
- The operating conditions are assumed to be standard.

MTIU-09HWFN1-M

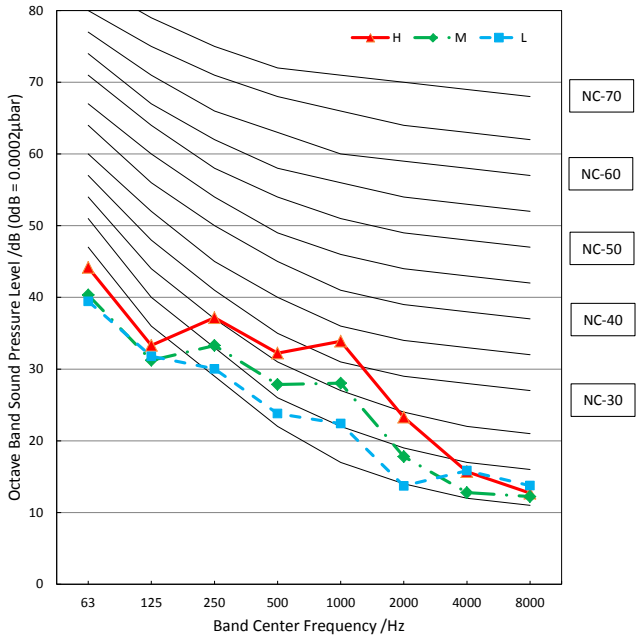

MTIU-12HWFN1-M

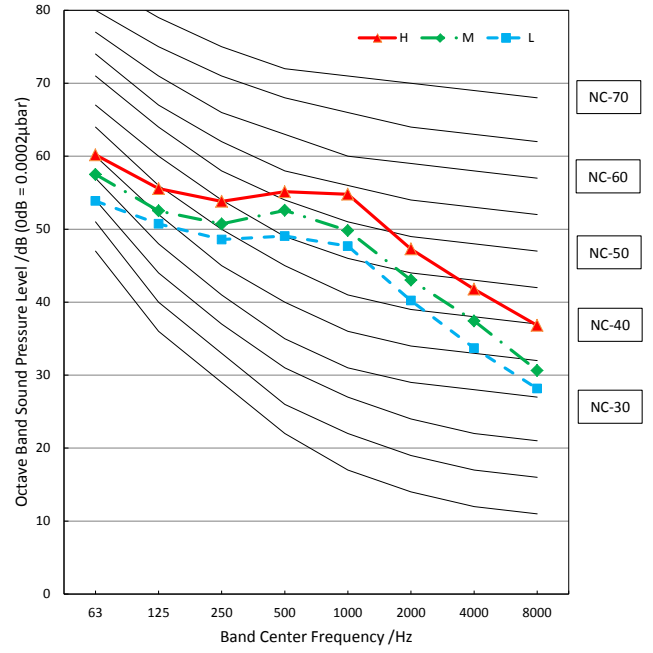

MTIU-18HWFN1-M

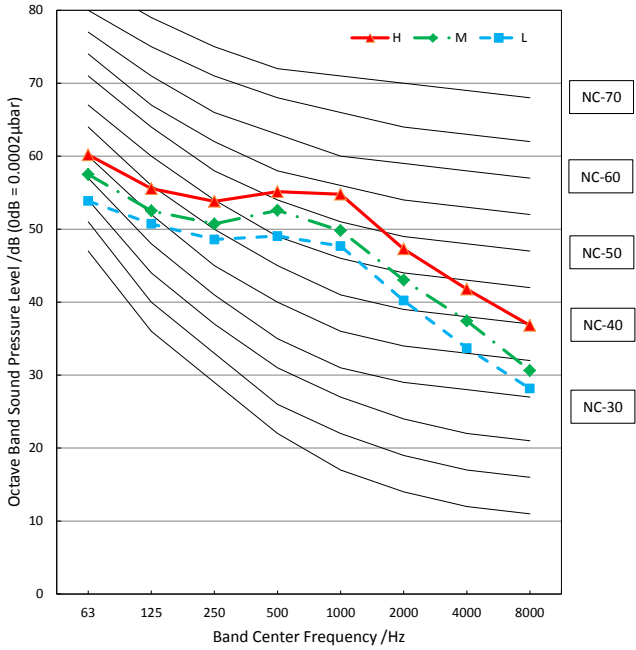

MTIU-24HWFN1-M

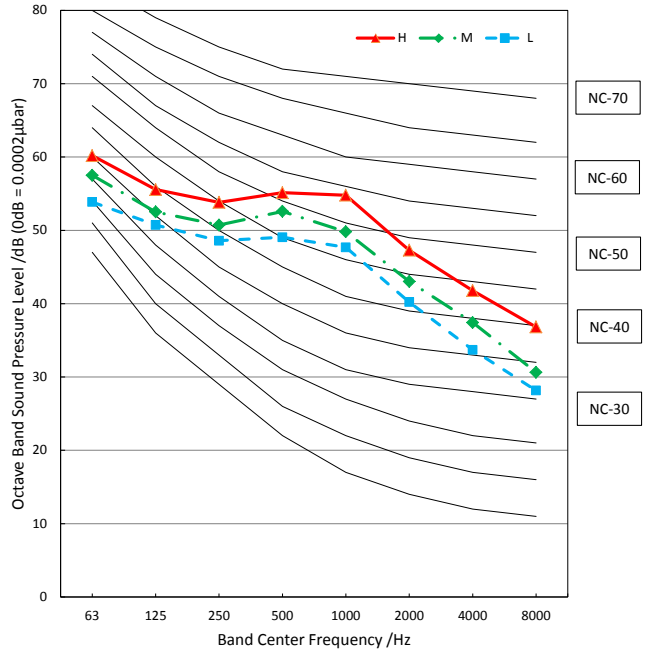

MTI-36HWFN1-M

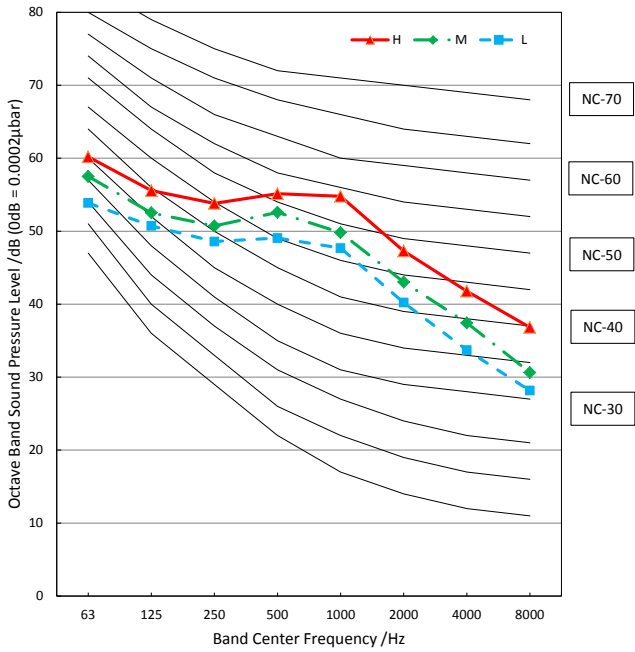

MTI-48HWFN1-M

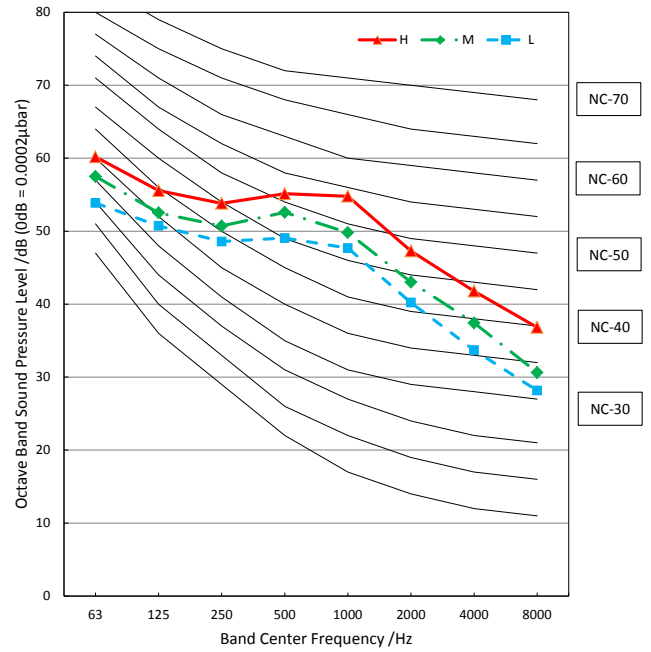

MHG-60HWFN1-MW

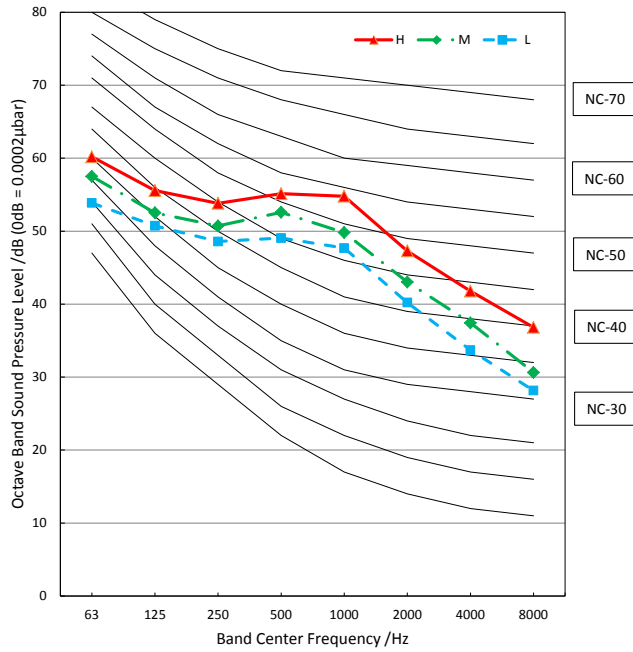

8.2 Outdoor Unit

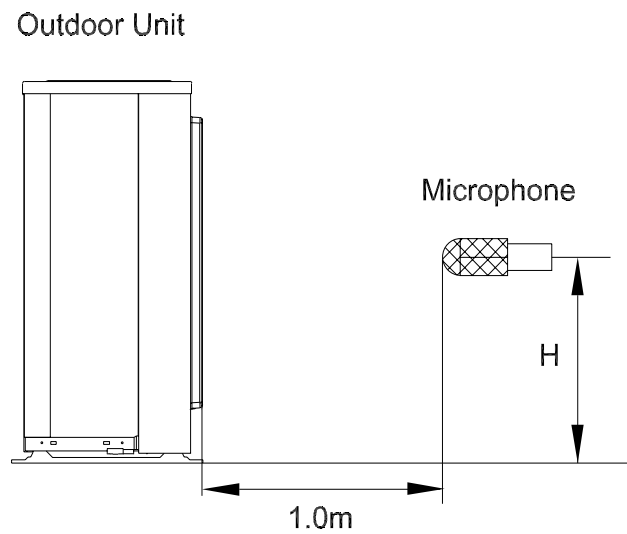

Note: $H = 0.5 \times$ height of outdoor unit

Notes:

- Sound measured at 1.0m away from the center of the unit.
- Data is valid at free field condition
- Data is valid at nominal operation condition
- Reference acoustic pressure $OdB=20\mu Pa$
- Sound level will vary depending on arrangement of factors such as the construction (acoustic absorption coefficient) of particular room in which the equipment is installed.
- The operating conditions are assumed to be standard.

MOBA30-09HFN1-MTOW

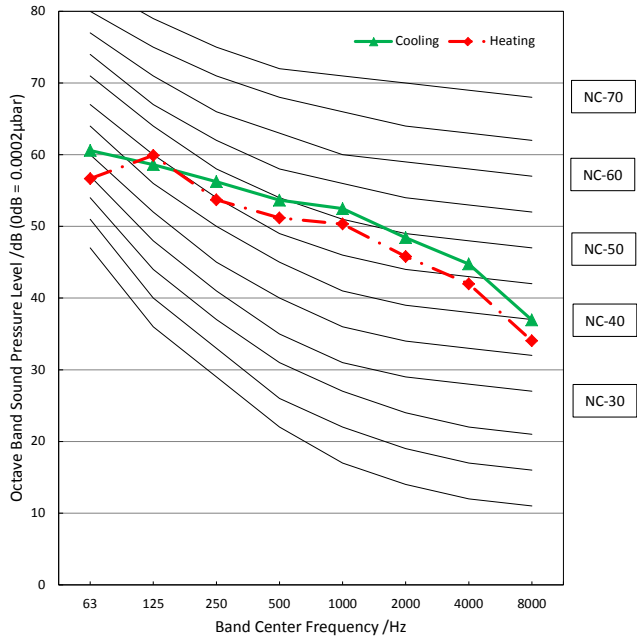

MOB30-12HFN1-MTOW

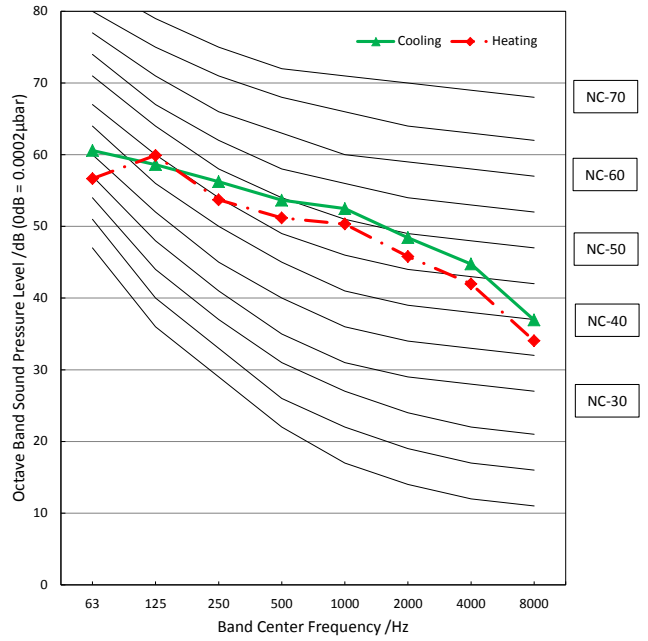

MOCA31-18HFN1-MTOW

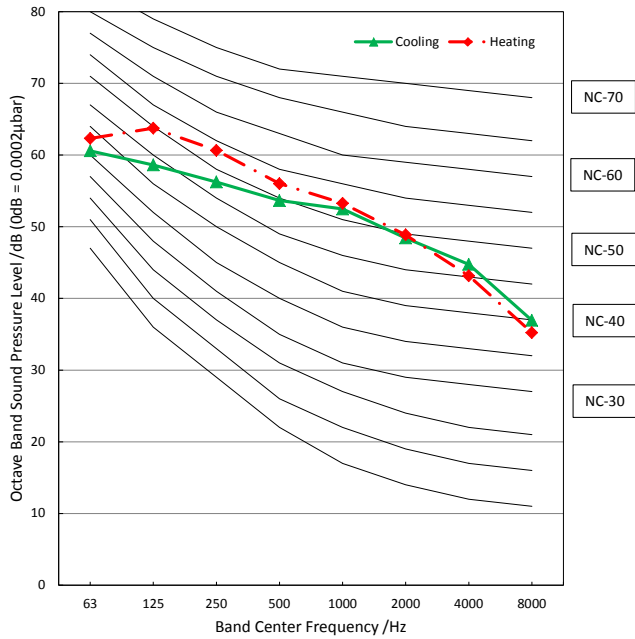

MOD31-24HFN1-MTOW

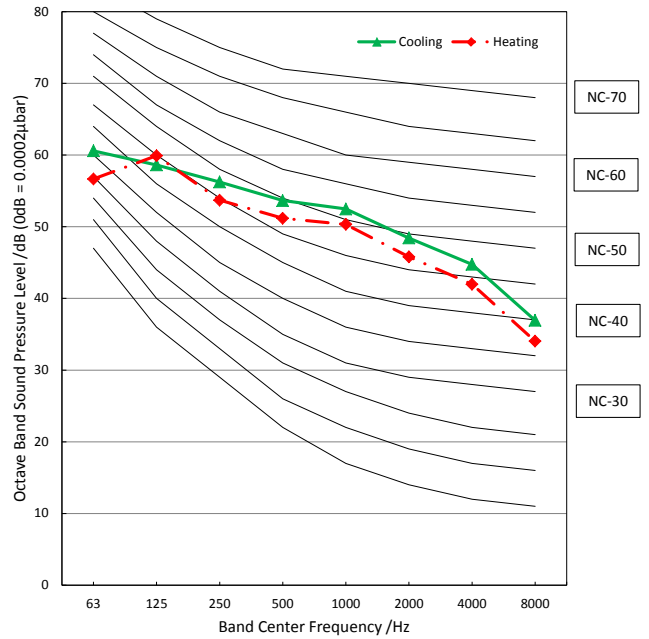

MOD30U-36HFN1-M

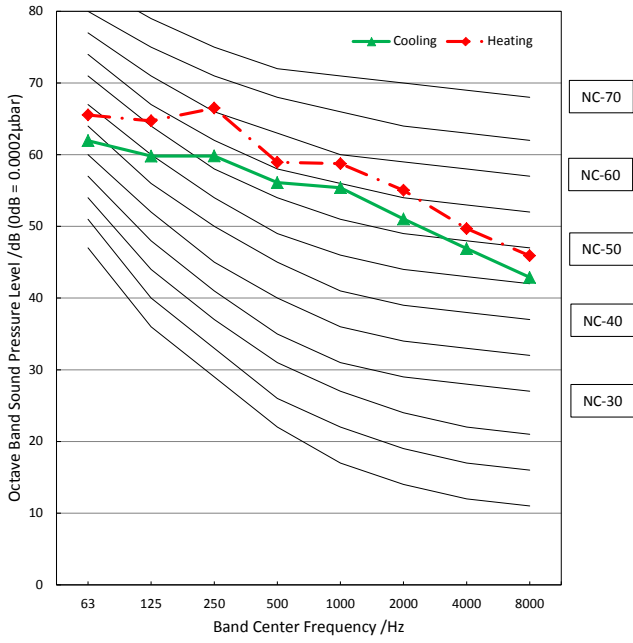

MOE30U-48HFN1-M

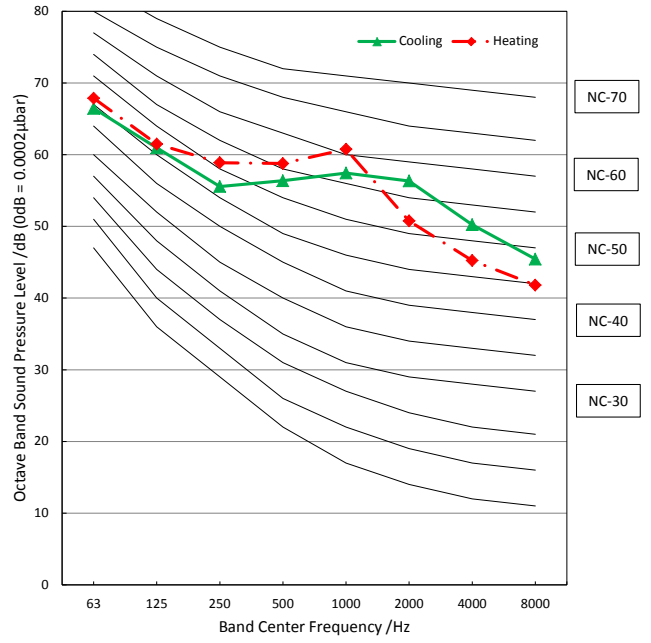

MOE30U-60HFN1-M

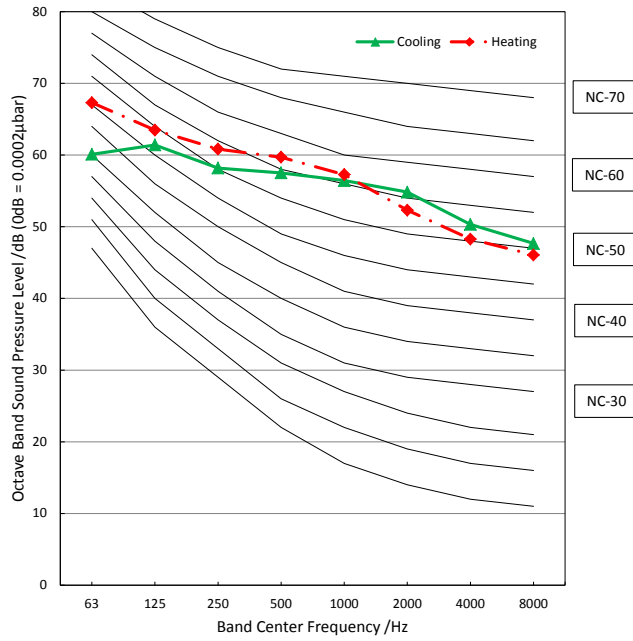

9. Electrical Characteristics

Type		9000~24000 Btu/h	36000 Btu/h	48000~60000 Btu/h
Phase		1-phase	1-phase	1-phase
Frequency and Voltage		208-230V, 60Hz	208-230V, 60Hz	208-230V, 60Hz
Circuit Breaker/ Fuse (A)		25/20	40/30	50/40
Indoor Unit Power Wiring		/		
Outdoor Unit Power Wiring		3-core cable (14AWG)	3-core cable (12AWG)	3-core cable (10AWG)
Indoor/Outdoor Connecting Wiring	Strong Electric Signal	4-core cable (16AWG)	3-core cable (16AWG)	3-core cable (16AWG)
		4-core cable (14AWG) (with auxiliary electric heater)	3-core cable (14AWG) (with auxiliary electric heater)	3-core cable (14AWG) (with auxiliary electric heater)
	Weak Electric Signal	/		2-core shielded cable (24AWG)

10. Static Pressure

9K

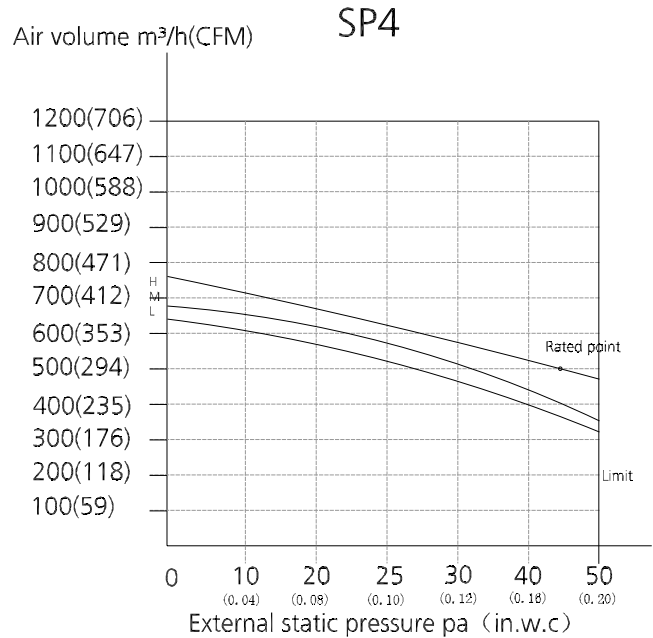
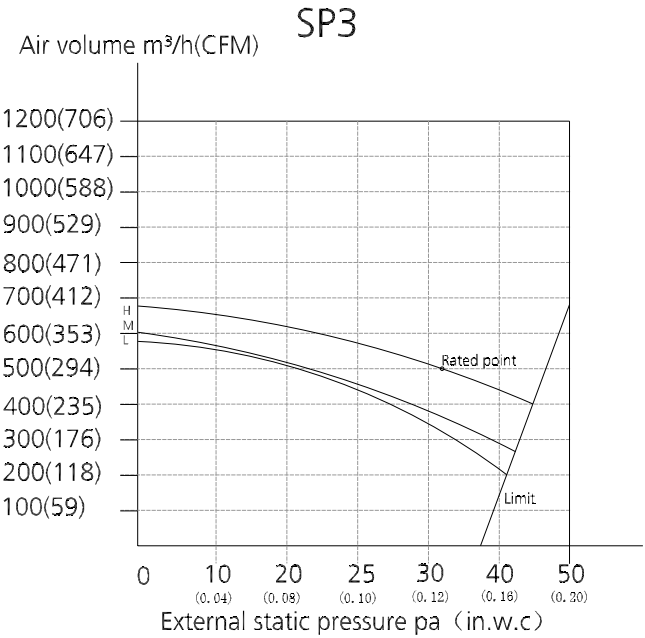
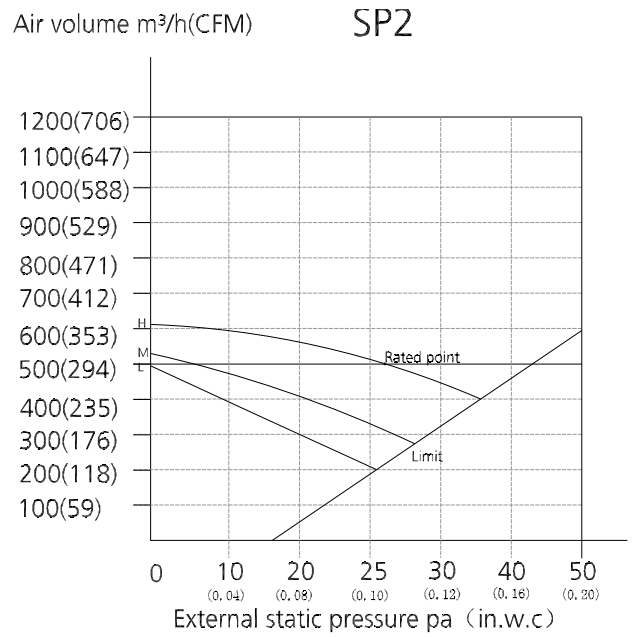
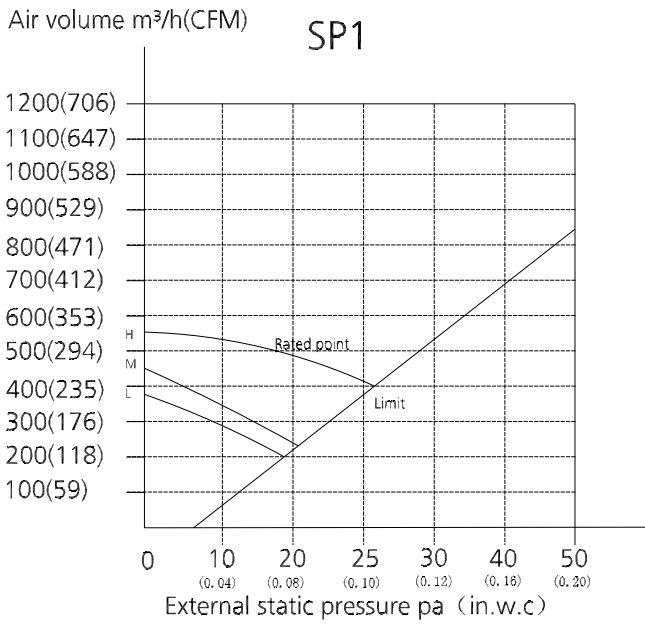

12K

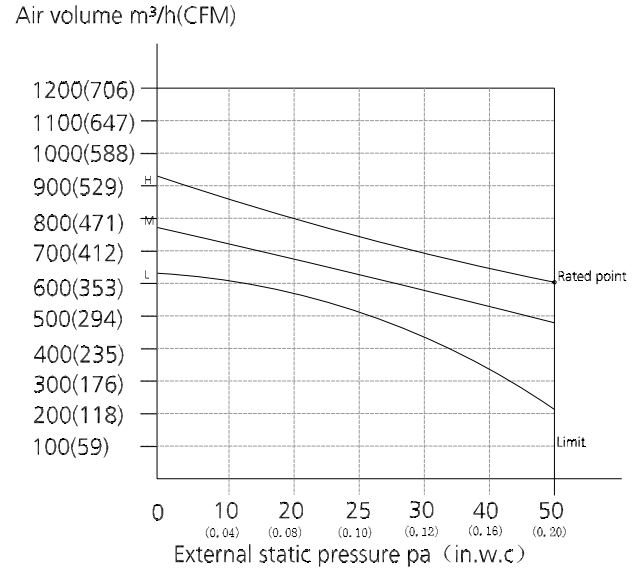
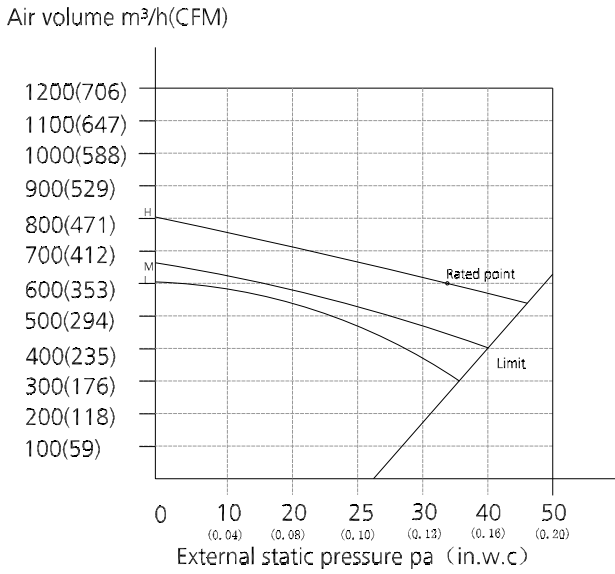
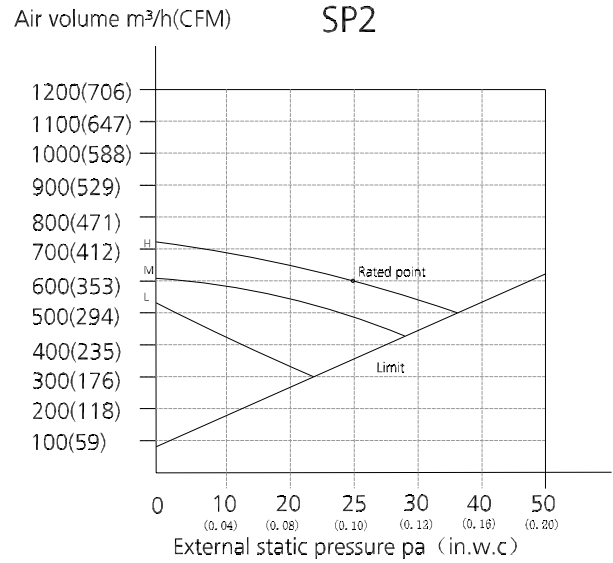
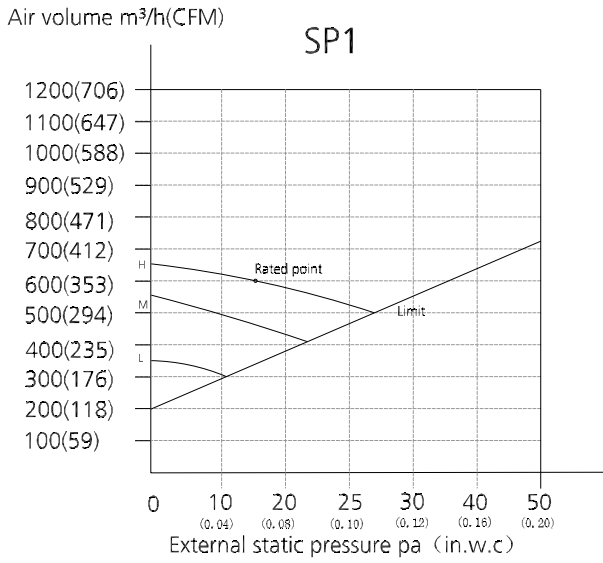

18K

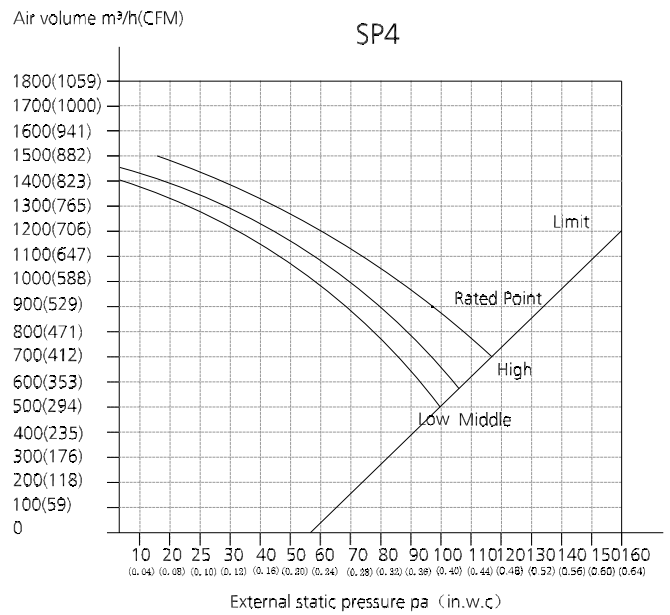
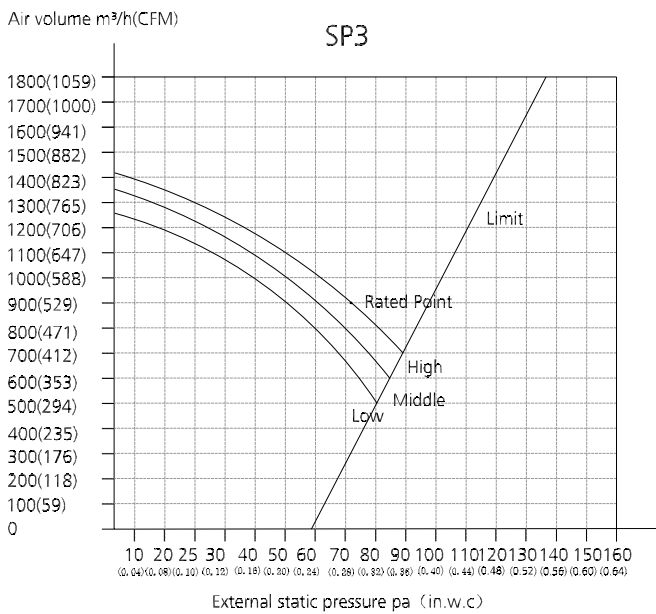
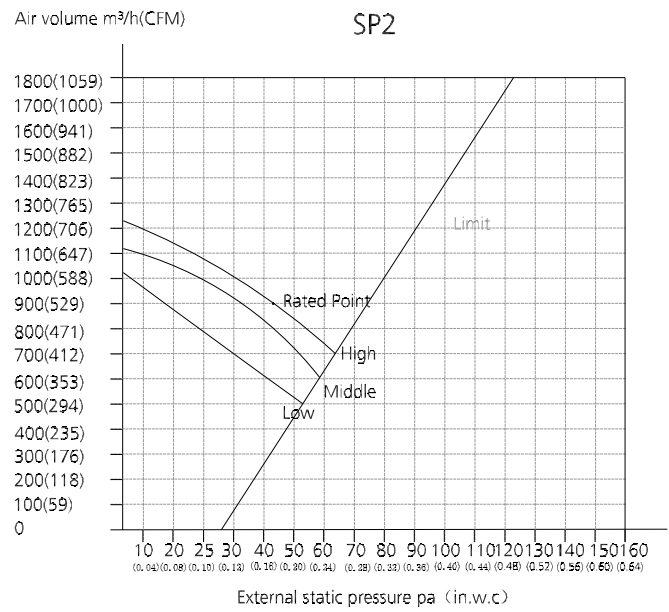
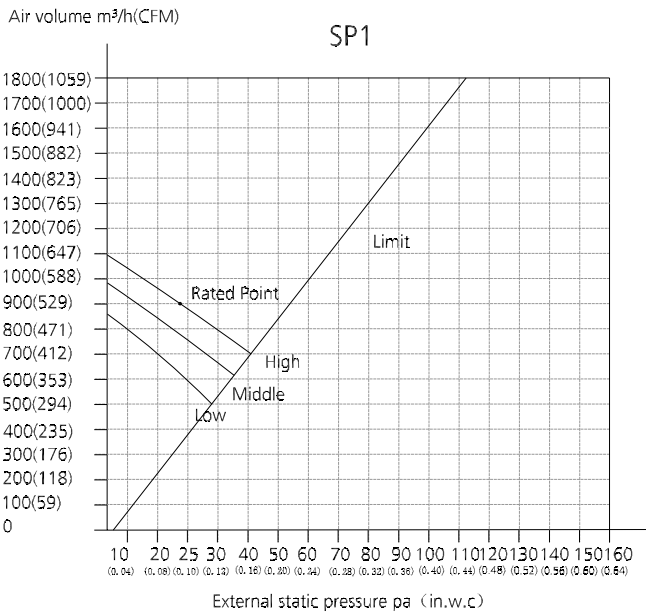

24K

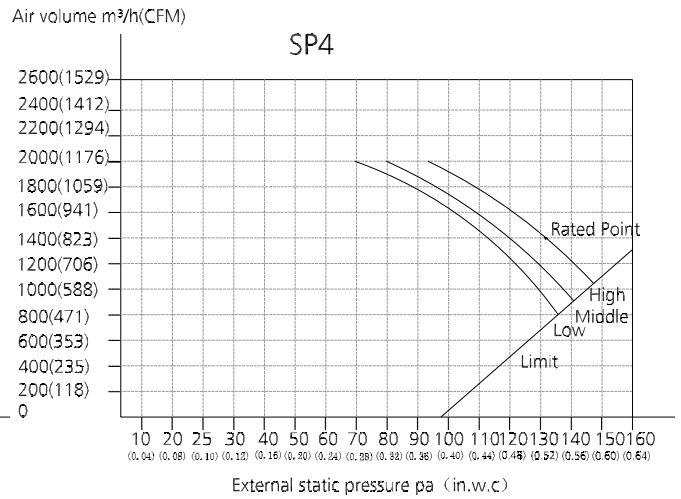
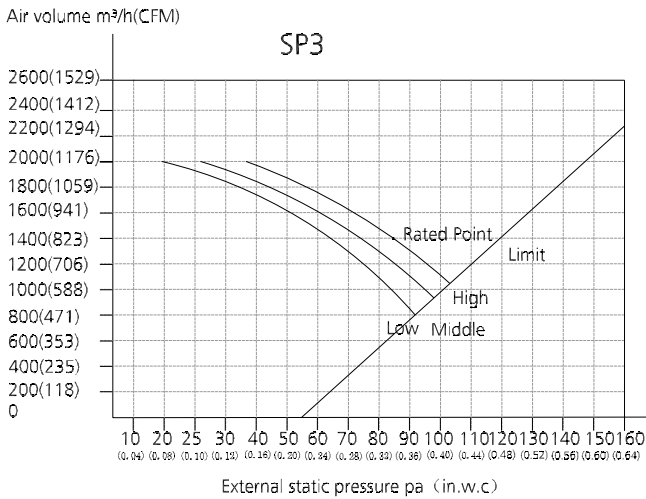
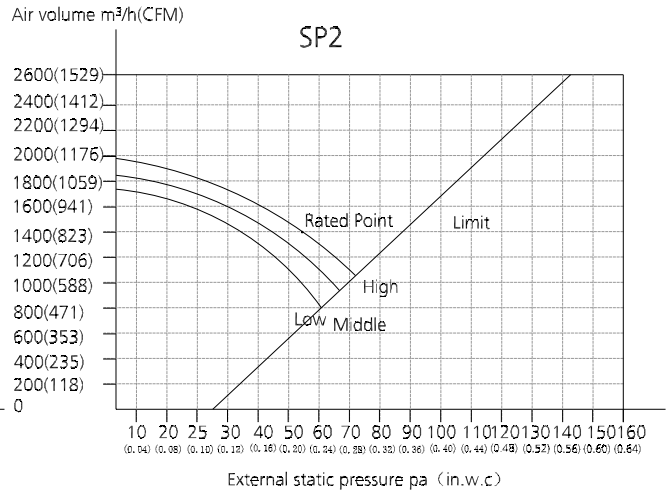
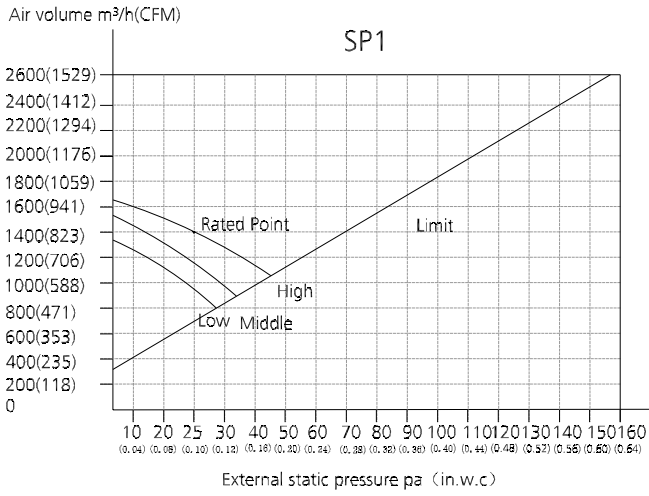

36K

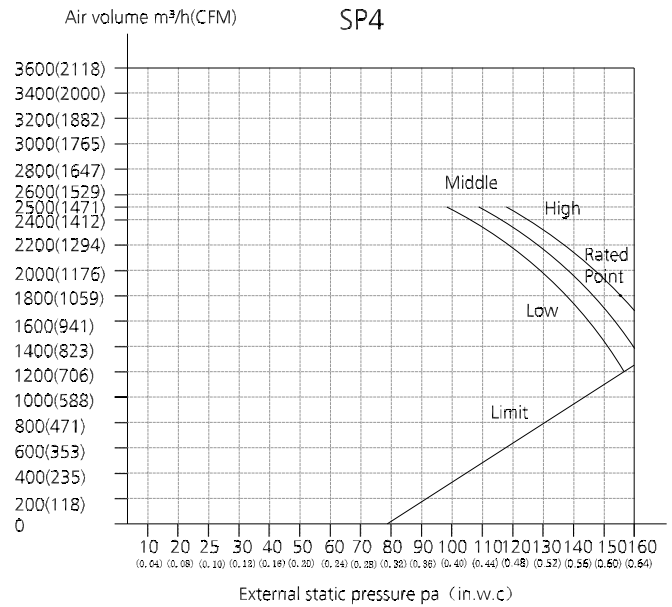
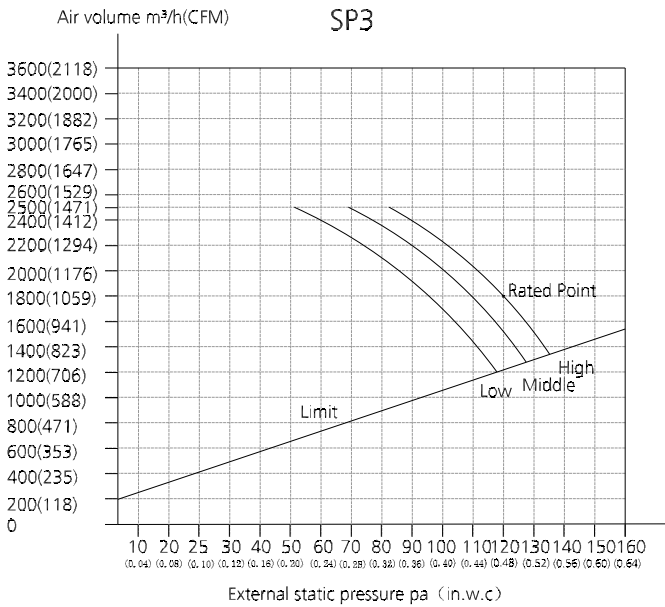
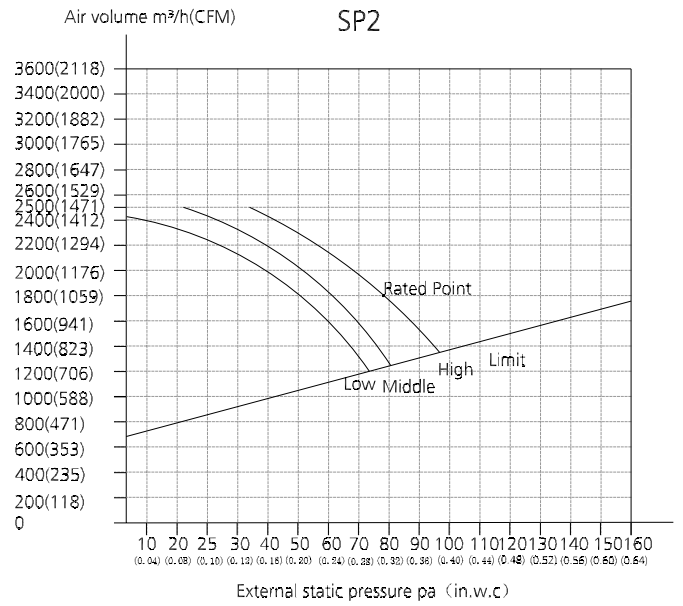
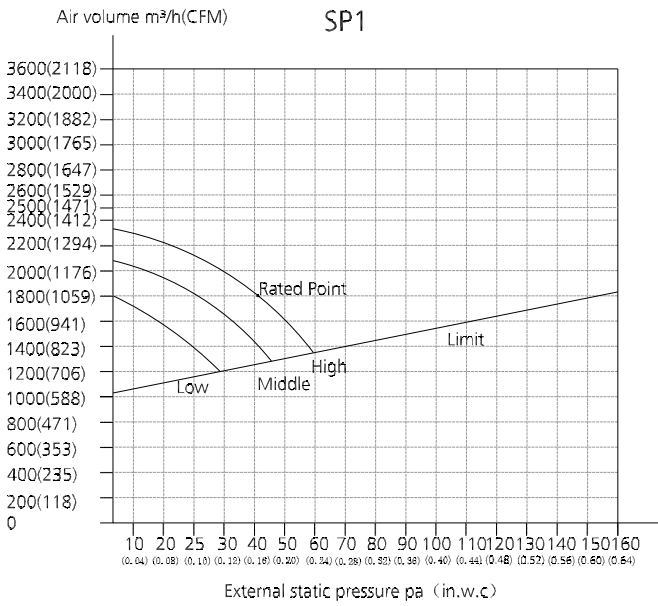

48K/60K

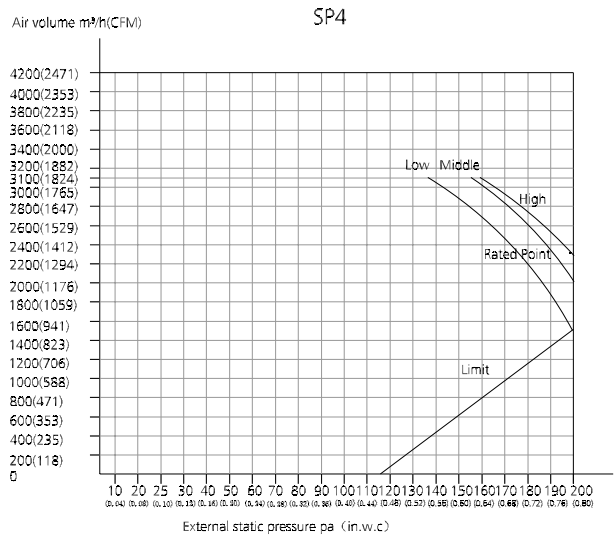
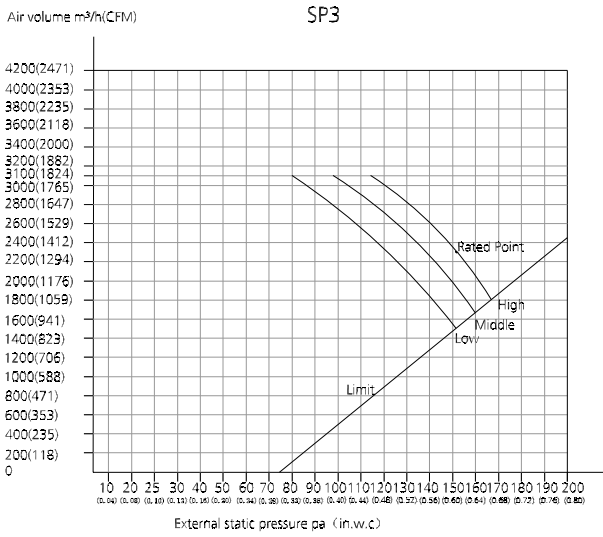
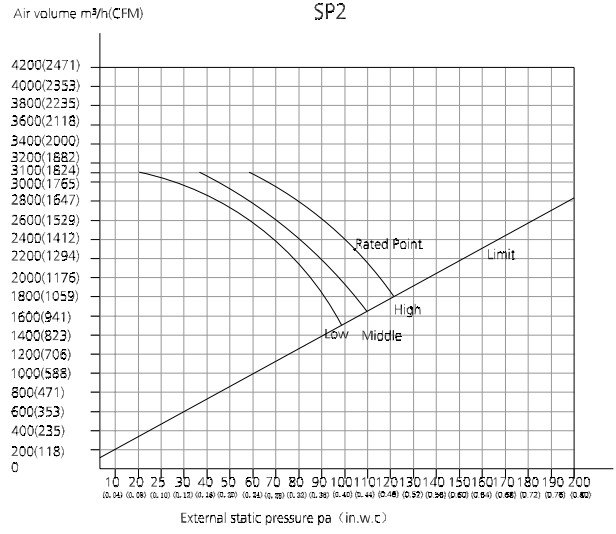
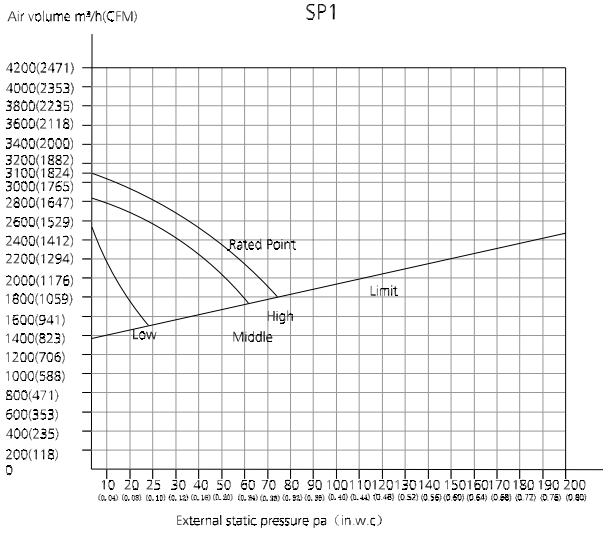

Constant air volume

9K

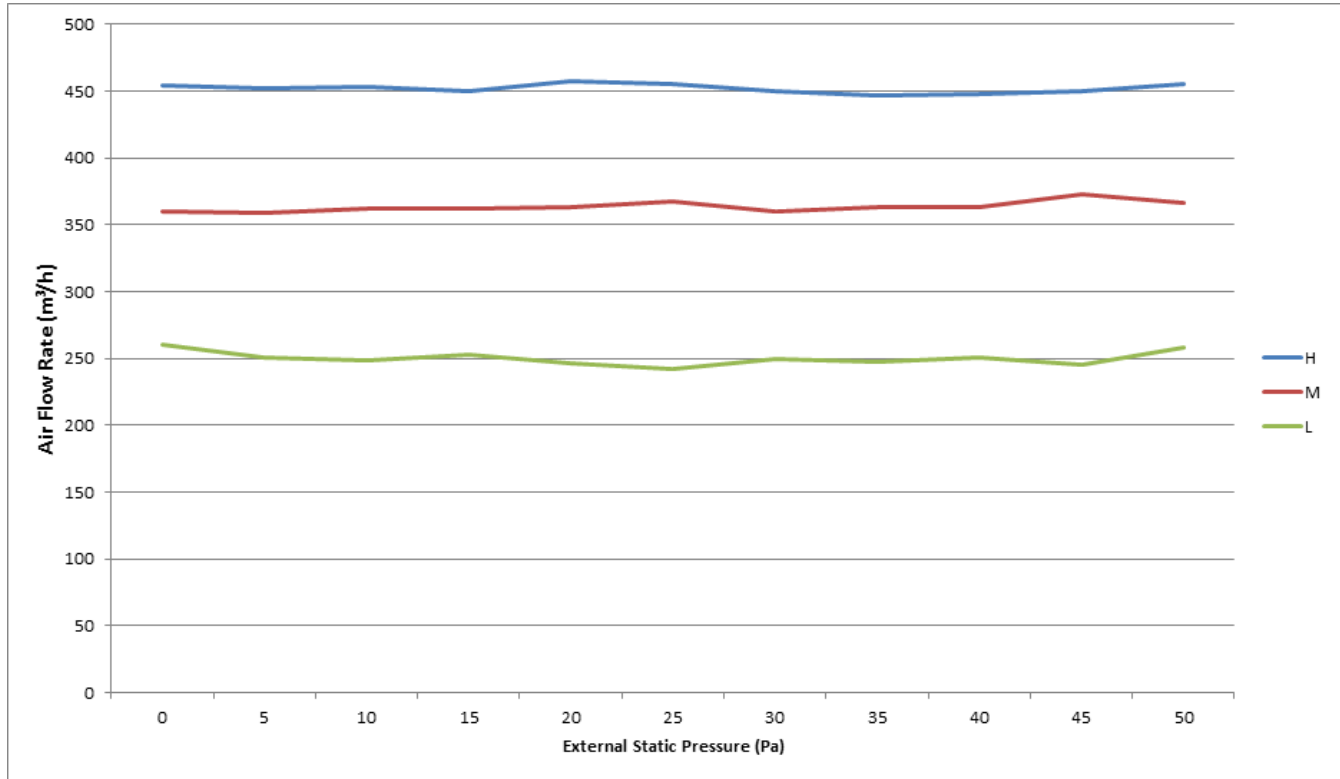

12K

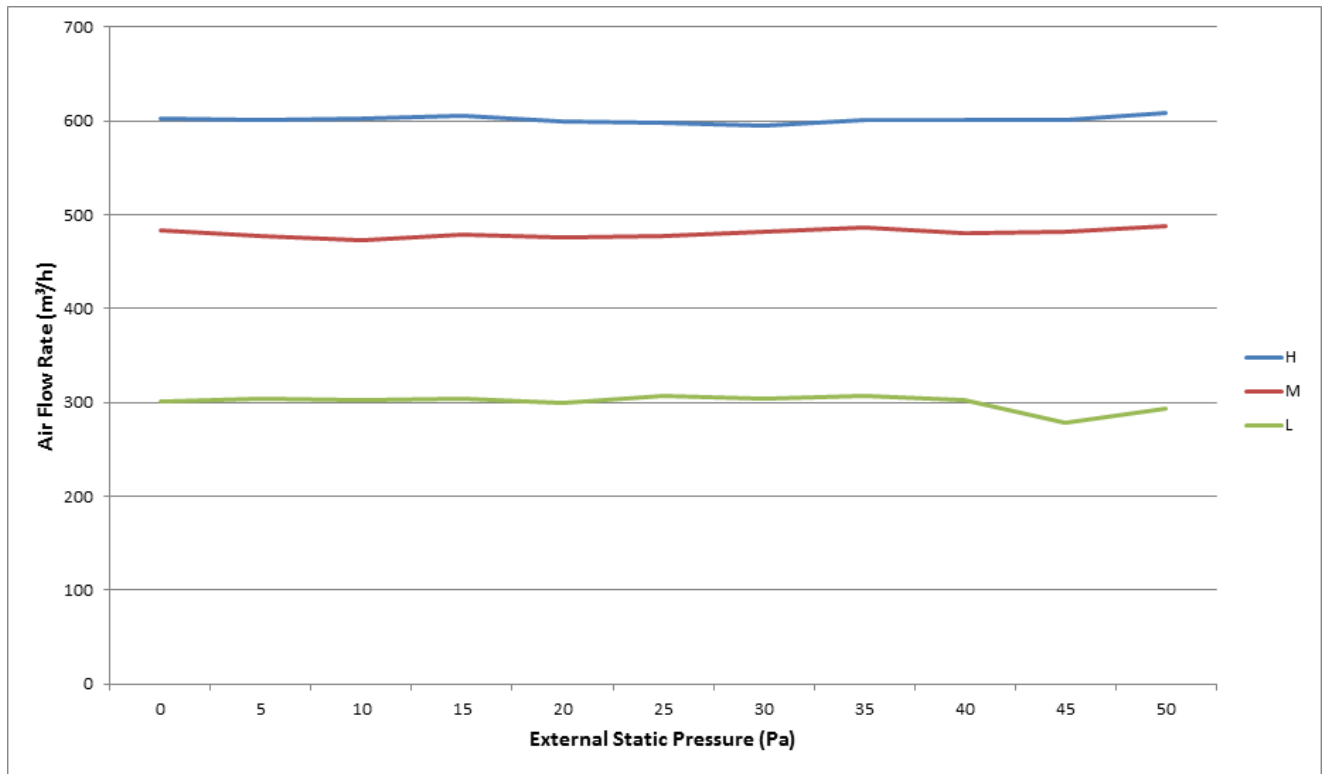

18K

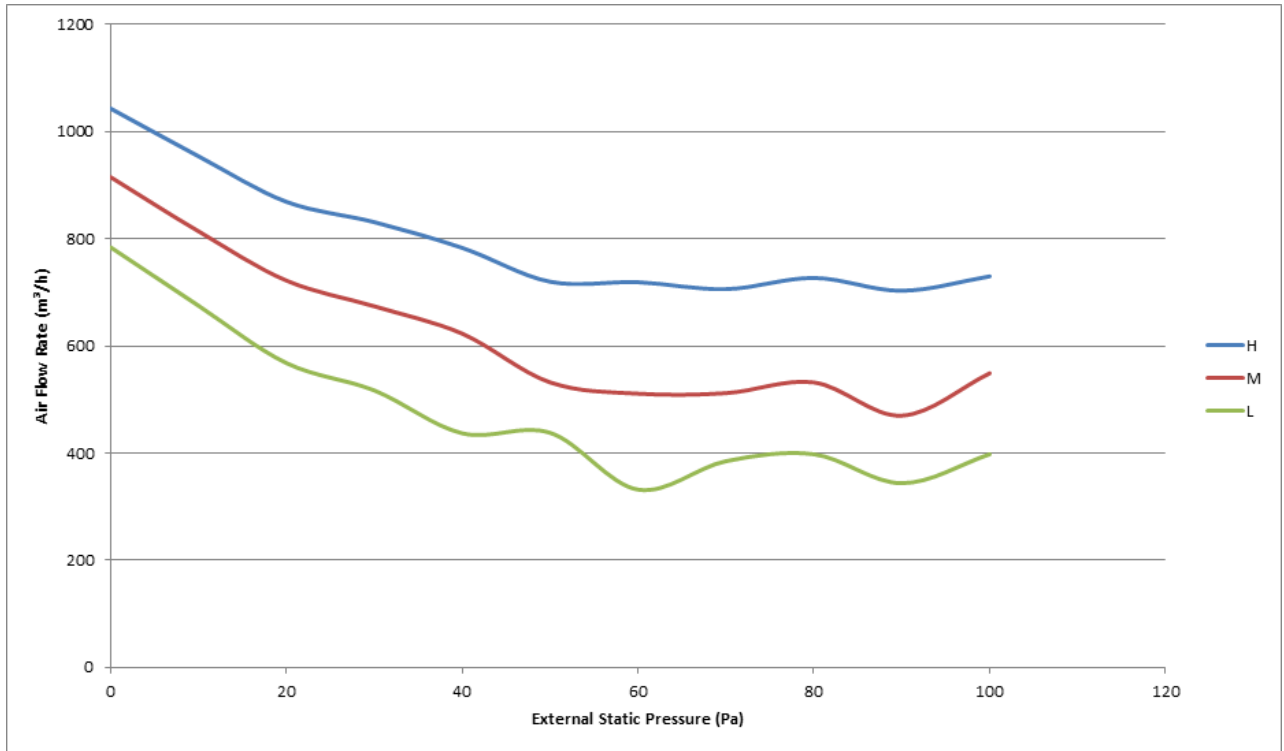

24K

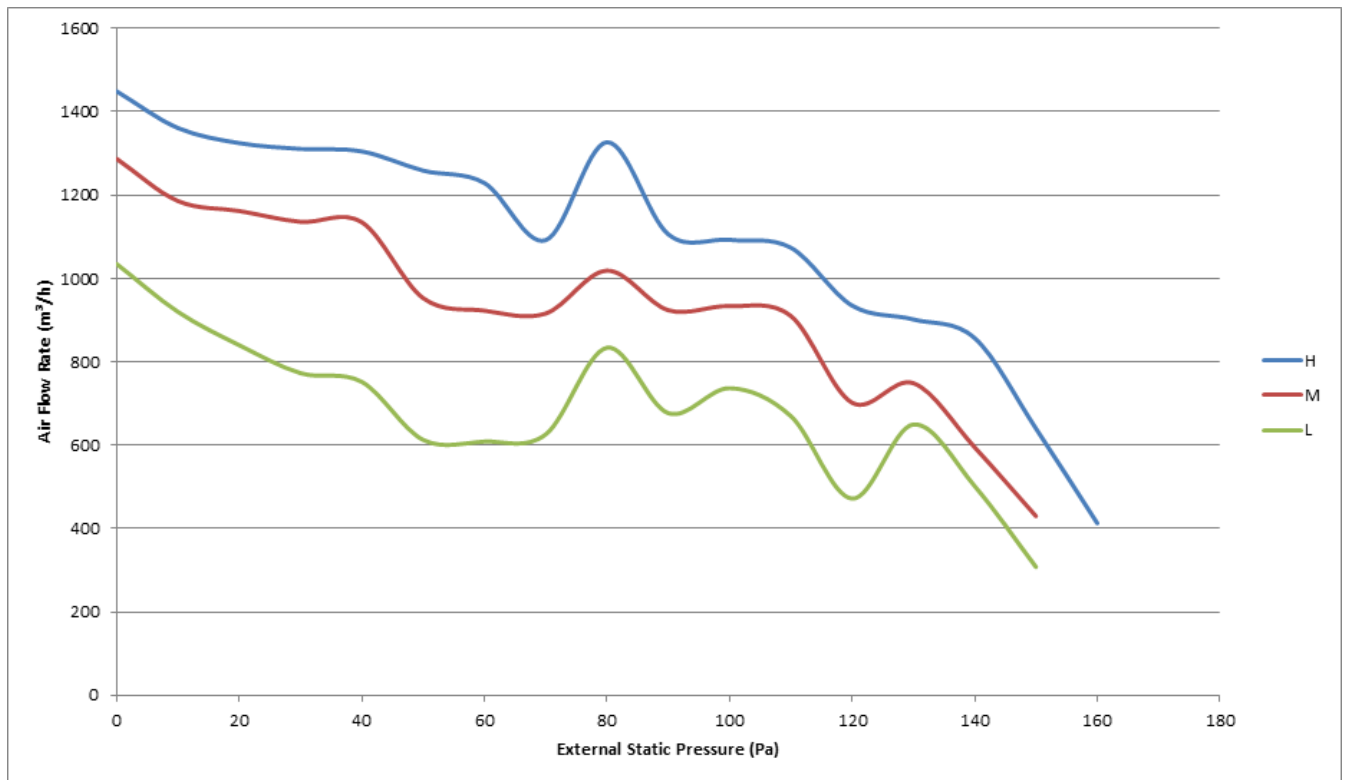

36K

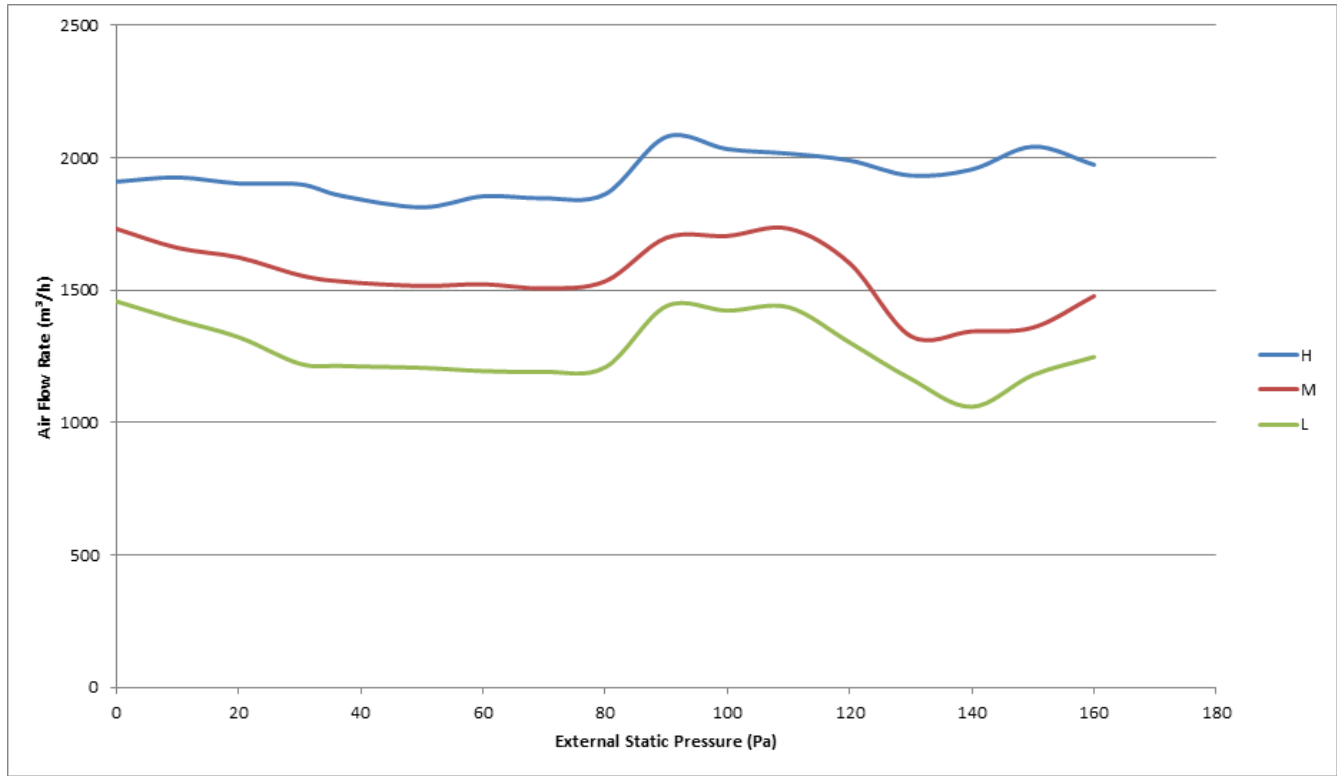

48K/60K

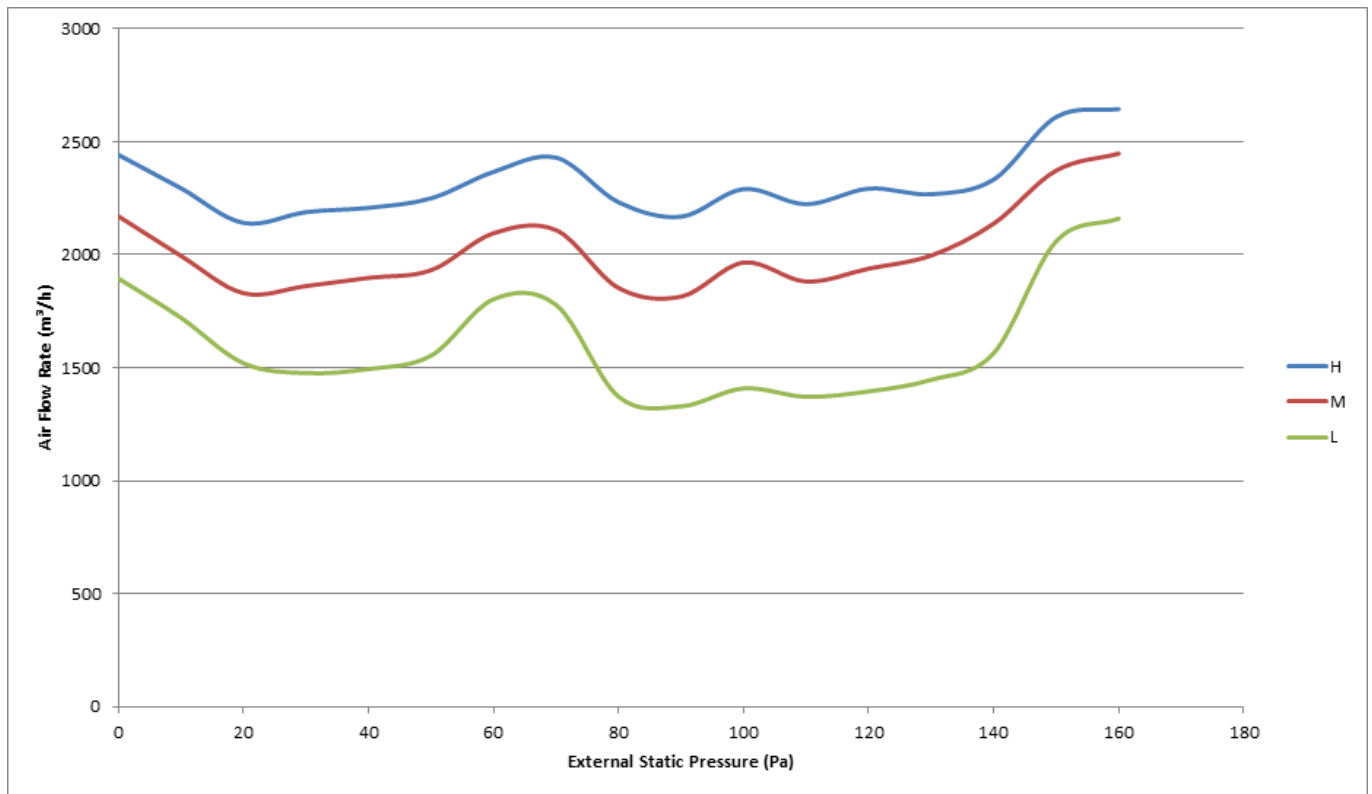

Product Features

Contents

1.	Operation Modes and Functions	57
1.1	Abbreviations	57
1.2	Safety Features	57
1.3	Display Function	57
1.4	Fan.....	57
1.5	Cooling Mode	57
1.6	Heating Mode (Heat pump models).....	58
1.7	Auto Mode.....	58
1.8	Drying Mode	58
1.9	Timer Function	58
1.10	Sleep Function.....	58
1.11	Auto-Restart.....	59
1.12	Follow Me	59
1.13	Drain Pump Control.....	59
2.	Remote Controller Functions	60
2.1	LCD Wired Remote Controller	60
2.2	Centralized Controller	69
2.3	Using the wire controller to set external static pressure	70
2.4	Using the wire controller to set airflow rate	70

1. Operation Modes and Functions

1.1 Abbreviation

Unit element abbreviations

Abbreviation	Element
T1	Indoor room temperature
T2	Coil temperature of evaporator
T3	Coil temperature of condenser
T4	Outdoor ambient temperature
T5	Compressor discharge temperature

1.2 Safety Features

Compressor three-minute delay at restart

Compressor functions are delayed for up to one minute upon the first startup of the unit, and are delayed for up to three minutes upon subsequent unit restarts.

Low Pressure Check Function(For 36K~60K)

The low pressure switch should be always closed. If it is open, the system will stop until the fault is cleared. During defrosting procedure , 4 minutes after defrosting ends and 5 minutes after compressor is on in heating mode, low pressure switch won't be checked.

Note: The system will not check if the protection could be cleared in 30 seconds after the protection occurs. If this protection occurs 3 times, it won't recover automatically until the main power is cut off.

Over-current protection

When compressor is running, if the current is over twice of the rated for 3 seconds, the compressor will stop and an error code will be displayed on the outdoor PCB. If the current becomes normal, the indoor sends signal to the outdoor, the outdoor will display normally.

Open Circuit/Disconnection Sensor Protection

Fan Speed Malfunction

If a fault occurs on the air volume regulator or the regulator enters protection mode, it sends the error message CF and an instruction to reduce fan speed to the master. The message and the instruction can be inquired with the remote controller or the wired controller. (Fault and protection information are displayed for one minute). After a fault occurs, the master unit shows the error code E3 and the fault count for one minute.

If the fault occurs three times, then the fan is unable to resolve the problem independently. External shutdown by a remote controller, wired controller, or central controller

must be used to clear the fan fault and fault count. The fan runs normally for 5 minutes while clearing fault count.

1.3 Display Function

Unit display functions

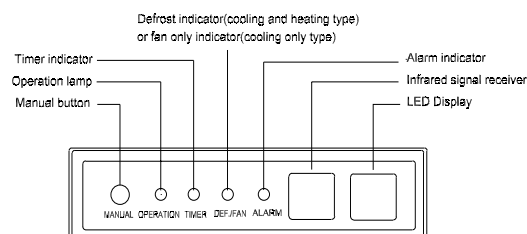

1.4 Fan

When fan mode is activated:

- The outdoor fan and compressor are stopped.
- Temperature control is disabled and no temperature setting is displayed.
- The indoor fan speed can be set to high, medium, low, or auto.
- The louver operations are identical to those in cooling mode.

1.5 Cooling Mode

1.5.1 Compressor Control

- When $T1-Ts-\Delta T$ is lower than setting value, the compressor ceases operation.
- When $T1-Ts-\Delta T$ is higher than setting value, the compressor continues operation.

1.5.2 Indoor Fan Control

- In cooling mode, the indoor fan operates continuously. The fan speed can be set to high, medium, low or auto.
- The auto fan acts according to the value of $T1-Ts$.

1.5.3 Outdoor Fan Control

- The outdoor fan is controlled by $T4$ and compressor frequency.

1.5.4 Evaporator Temperature Protection

When evaporator temperature drops below a configured value for some time, the compressor ceases operation, the outdoor fan motor ceases operation 30 seconds later.

1.5.5 Condenser Temperature Protection

When condenser temperature is more than setting value, the compressor ceases operations.

1.6 Heating Mode(Heat pump models)

1.6.1 Indoor Fan Control:

- When the compressor is on, the fan speed can be set to high, medium, low, or auto. And the anti-cold wind function has the priority.
- The auto fan acts according to the value of T1-Ts.

1.6.2 Outdoor Fan Control:

- The outdoor fan is controlled by T4 and compressor frequency.

1.6.3 Defrosting mode

- The unit enters defrosting mode according to the value of temperature of T3 and the value range of temperature change of T3 and also the compressor running time.
- If any one of the following items is satisfied, the defrosting will finish and the machine will turn to normal heating mode.
 - T3 rises to be higher than TCDE1°C.
 - T3 keeps to be higher than TCDE2°C for 80 seconds.
 - The machine has run for 10 minutes in defrosting mode.

1.6.4 Evaporator Temperature Protection

When the evaporator temperature exceeds a preset protection value, the compressor ceases operations, the outdoor fan motor ceases operation 30 seconds later.

1.7 Auto Mode

- This mode can be selected with the remote controller and the temperature setting can be adjusted between 17°C~30°C
- In auto mode, the machine selects cooling, heating, or fan-only mode on the basis of ΔT ($\Delta T = T1 - Ts$).

ΔT	Running mode
$\Delta T > 2\text{ C (3.6 F)}$	Cooling
$-2\text{ C (-3.6 F)} \leq \Delta T \leq 2\text{ C (3.6 F)}$	Fan-only
$\Delta T < -2\text{ C (3.6 F)}$	Heating*

Heating*: In auto mode, cooling only models run the fan.

- Indoor fans run at the auto fan speed of the relevant mode.
- The louver operates the same as in relevant mode.
- If the machine switches mode between heating and cooling, the compressor pauses for a certain period of time intermittently and then selects a mode based on T1-Ts.

- If the setting temperature is modified, the machine selects a new running function.

1.8 Drying Mode

- Indoor fan speed is fixed at low and cannot be changed.
- All protections are activated and operate the same as they do in cooling mode.
- The louver operates the same as in cooling mode.

1.9 Timer Function

- The timing range is 24 hours.
- Timer On. The machine turns on automatically at the preset time.
- Timer Off. The machine turns off automatically at the preset time.
- Timer On/Off. The machine turns on automatically at the preset On Time, and then turns off automatically at the preset Off Time.
- Timer Off/On. The machine turns on automatically at the preset Off Time and then turns off automatically at the preset On Time.
- The timer does not change the unit operation mode. If the unit is off now, it does not start up immediately after the "timer off" function is set. When the setting time is reached, the timer LED switches ioff and the unit running mode remains unchanged.
- The timer uses relative time, not clock time

1.10 Sleep Function

- The sleep function is available in cooling, heating, or auto mode.
- The operational process for sleep mode is as follows:
 - When cooling, the temperature rises 1°C (1.8°F) (to not higher than 30°C (86°F)) every hour. After 2 hours, the temperature stops rising and the indoor fan is fixed to auto speed.
 - When heating, the temperature decreases 1°C (1.8°F) (to not lower than 17°C (62.6°F)) every hour. After 2 hours, the temperature stops decreasing and the indoor fan is fixed at auto speed. Anti-cold wind function takes priority.
- The operating time for sleep mode is 7 hours, after which, the unit exits this mode and switches off.
- The timer setting is available in this mode.

1.11 Auto-Restart

- The indoor unit has an auto-restart module that allows the unit to restart automatically. The module automatically stores the current settings (not including sleep mode) and, in the case of a sudden power failure, will restore those settings automatically within 3 minutes after power returns.
- If the unit was in forced cooling mode, it will run in this mode for 30 minutes and turn to auto mode with temperature set to 24°C (75.2°F).
- If there is a power failure while the unit is running, the compressor starts 3 minutes after the unit restarts. If the unit was already off before the power failure, the compressor starts 1 minute after the unit restarts.

1.12 Follow Me (Optional)

- If you press “Follow Me” on the remote, the indoor unit will beep. This indicates the follow me function is active.
- Once active, the remote control will send a signal every 3 minutes, with no beeps. The unit automatically sets the temperature according to the measurements from the remote control.
- The unit will only change modes if the information from the remote control makes it necessary, not from the unit’s temperature setting.

1.13 Drain Pump Control (Optional)

- Use the water-level switch to control drain pump.
- The system checks the water level every 5 seconds.
 - When the A/C operates in cooling (including auto cooling) or forced cooling mode, the pump begins running immediately and continuously until cooling stops.
 - If the water level increases up to the control point, the LED displays an alarm code and the drain pump opens and continually monitors the water level. If the water level falls and LED alarm code is no longer displayed (drain pump close delay is 1 minute), the unit goes back into its last mode. Otherwise, the entire system (including the pump) stops and the LED displays an alarm again after 3 minutes.

2. Remote Controller Functions

2.1 LCD Wired Remote Controller

2.1.1 LCD Wired Remote Controller KJR-120C/BTF-E(AU)(Standard)

i) Buttons and Functions

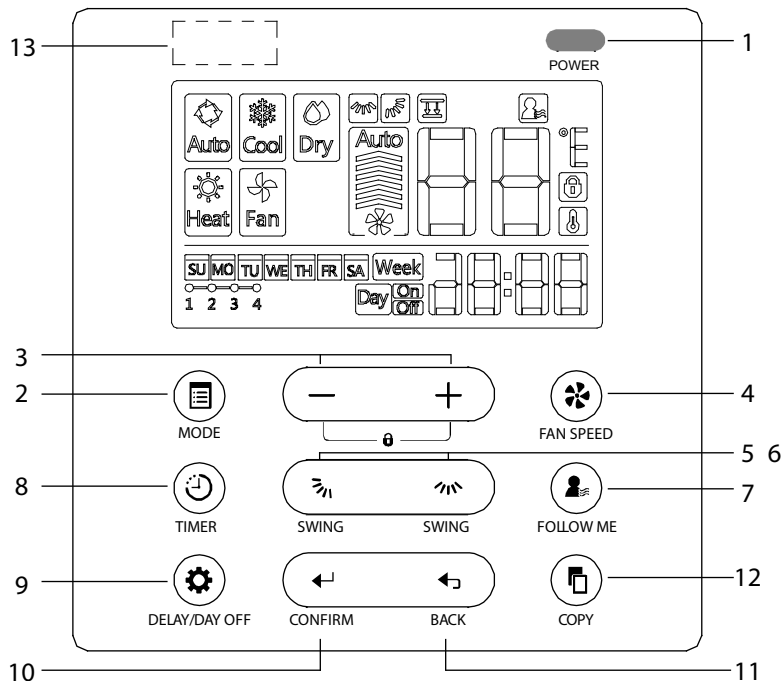

1. POWER button

Turn on or turn off the unit.

2. MODE(A/B) button

Used to select the operation mode: Auto / Cooling / Drying / Heating / Fan;

Hold to activate the operation of auto-lifting panel when off

3. Adjust button

To set temperature, time and timer; set up or down the auto-lifting panel

4. FAN SPEED button

Used to select the fan speed.

5. Up-down airflow direction and swing Button

Press for adjusting the angle of louver, hold for vertical swing; individual louver control for cassette panel

6. Left-right airflow swing Button

Press for activating the horizontal swing

7. FOLLOW ME(PTC) button

Allows the remote control to act as a remote thermostat and send temperature information from its current location.

8. TIMER button

To set timer on and timer off time of one day

9. DELAY/DAY OFF button

To set 1 to 2 hours delay off for each day or a whole day off in a weekly timer schedule

10. CONFIRM button

To confirm an setting or call up the menu

11. BACK button

Back to previous operation or superior menu

12. COPY button

Copy timer setting of one day to another in weekly schedule setting

13 Infrared remote receiver (on some models)

ii) LCD Screen

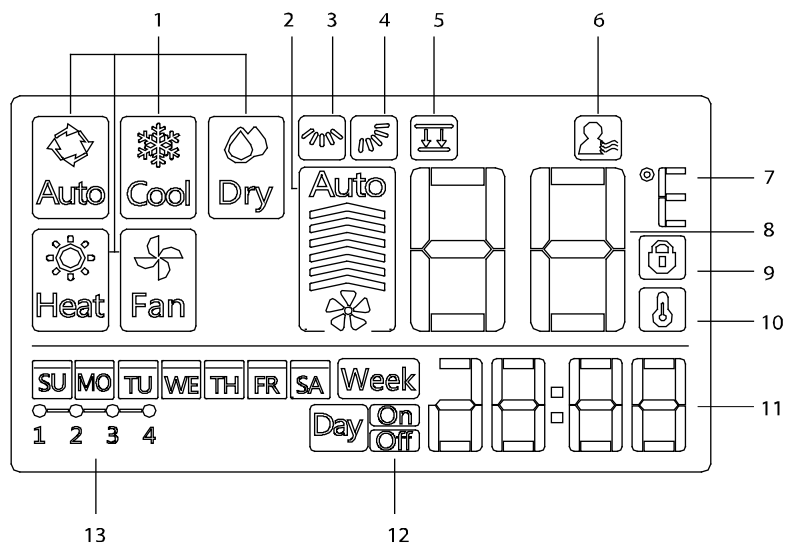

1 Operation mode indication

2 Fan speed indication

3 Left-right swing indication

4 Up-down swing indication

5 Faceplate function indication

6 Follow me function indication

7 C° / F° indication

8 Temperature display

9 Lock indication

10 Room temperature indication

11 Clock display

12 On/Off timer

13 Timer display

iii) Installation

- Dimensions

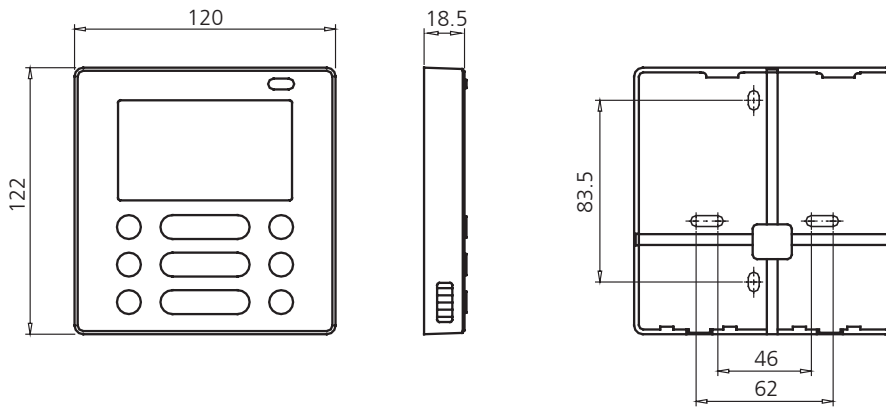

- Wiring diagram

Refer to the following diagram to wire the wall-mounted remote control to the indoor unit.

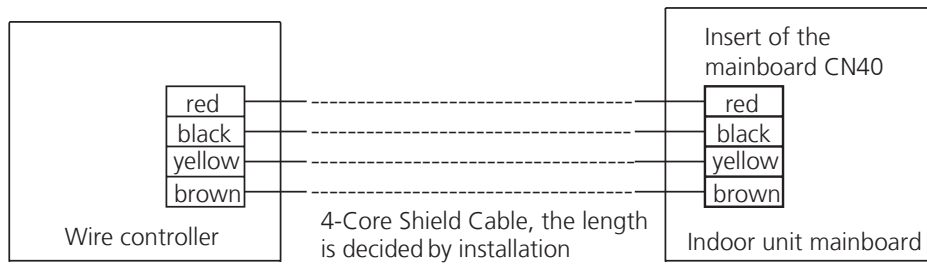

- Installation Diagram

Connect the female joint of wires group from the mainboard with the male joint of connective wires group. Then connect the other side of connective wires group with the male joint of wires group leads from wire controller.

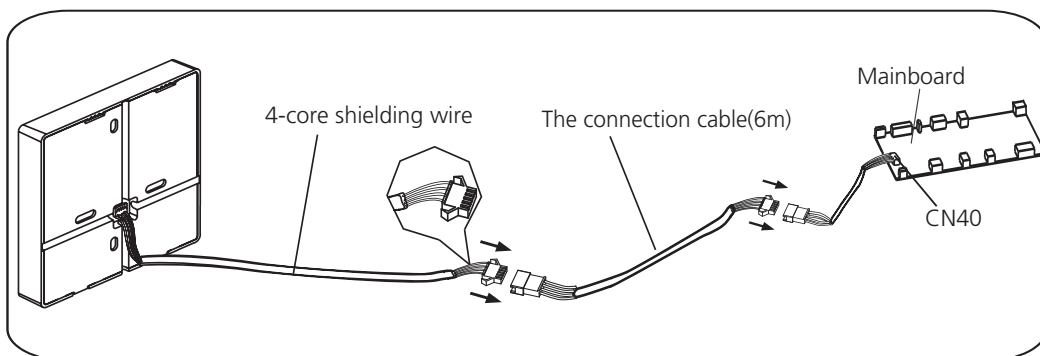

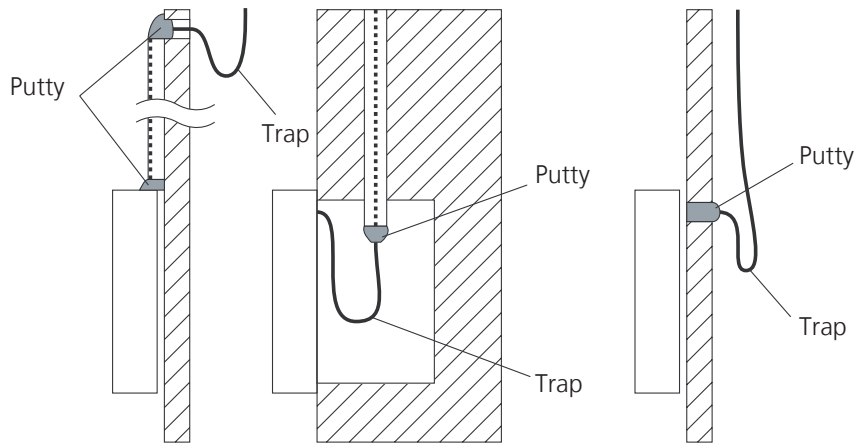

Note: DO NOT allow water to enter the remote control. Use the trap and putty to seal the wires.

- For exposed mounting, four outletting positions. There are three need cutting.

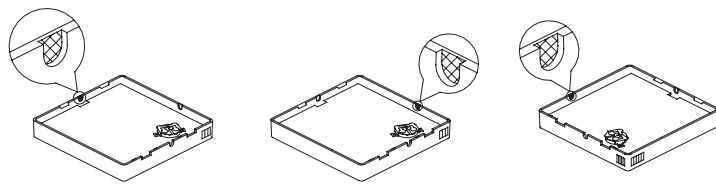

Cutting place of top side wire outlet

Cutting place of left side wire outlet

Cutting place of right side wire outlet

- For shielded wiring, please refer to the picture below.

Embedded switch box wiring

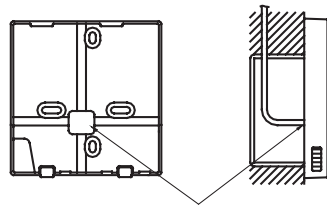

Wiring hole

Wiring through the wall

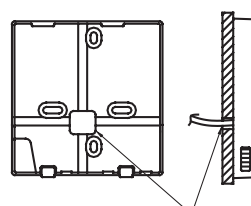

Wall hole and wiring hole
Diameter of wall hole: $\Phi 2\text{cm}$

2.1.2 LCD Wired Remote Controller KJR-120G/TF-E(Optional)

The KJR-120G/TF-E wired remote controller is optional for all types.

i) Buttons and Functions

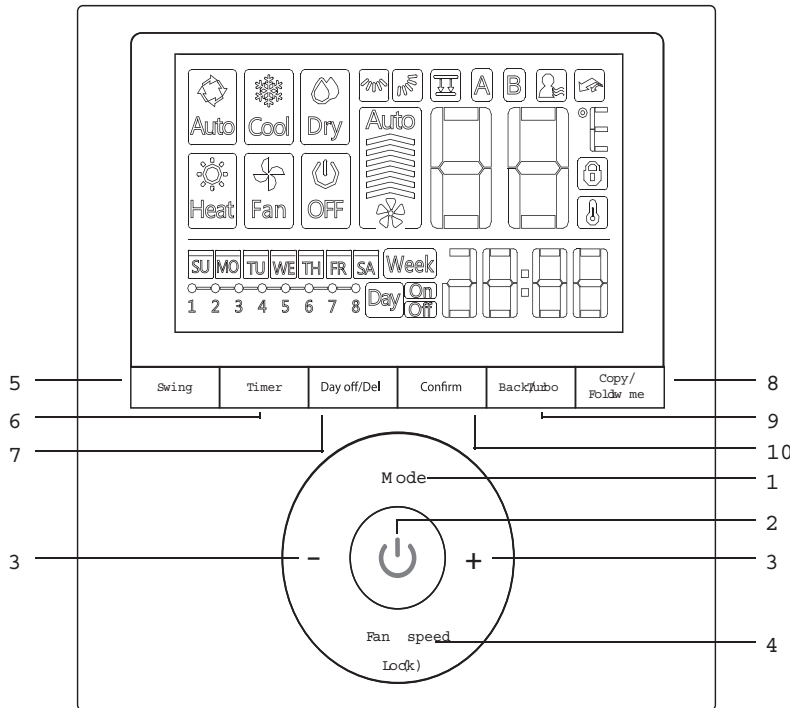

1. MODE button

Used to select the operation mode: Auto / Cooling / Drying / Heating / Fan;

Hold to activate the operation of auto-lifting panel when off

2. POWER button

Turn on or turn off the unit.

3. Adjust button

To set temperature, time and timer; set up or down the auto-lifting panel

4. FAN SPEED button

Used to select the fan speed.

5. Swing Button

Press to active vertical swing, hold for horizontal swing

6. TIMER button

To set timer on and timer off time of one day

7. DELAY/DAY OFF button

To set 1 to 2 hours delay off for each day or a whole day off in a weekly timer schedule

8. COPY/FOLLOW ME button

To copy timer setting of one day to another in weekly schedule setting;

To active the follow me function while in normal operation.

9. BACK/TURBO button

Back to previous operation or superior menu

To active turbo mode while in normal operation

10. CONFIRM button

To confirm an setting or call up the superior menu

ii) LCD Screen

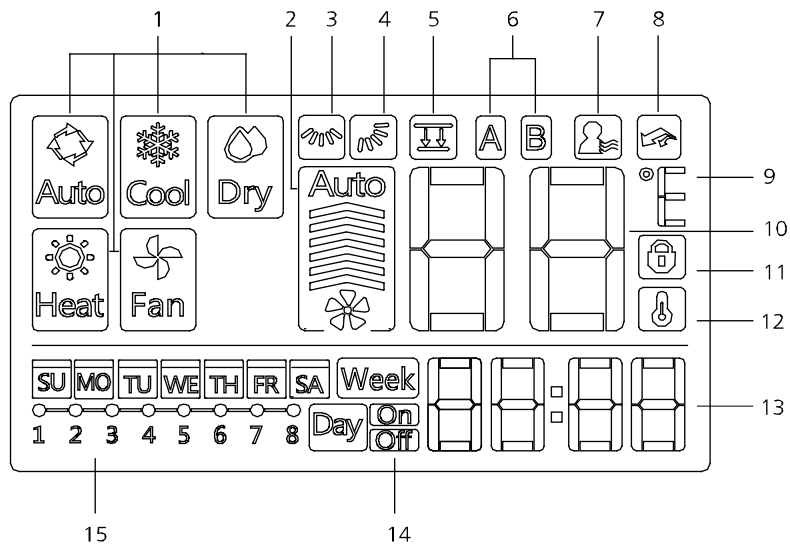

1 Operation mode indication

2 Fan speed indication

3 Left-right swing indication

4 Up-down swing indication

5 Faceplate function indication

6 Main unit and secondary unit indication

7 Follow me function indication

8 Turbo/PTC function indication

9 C° / F° indication

10 Temperature display

11 Lock indication

12 Room temperature indication

13 Clock display

14 On/Off timer

15 Timer display

iii) Installation

- Dimensions

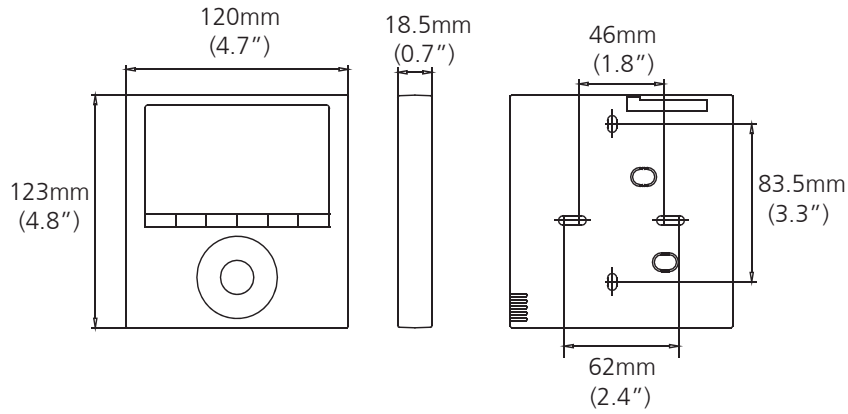

- Wiring diagram

1) Connection

For Cassette: The wired controller connects to main control board directly.

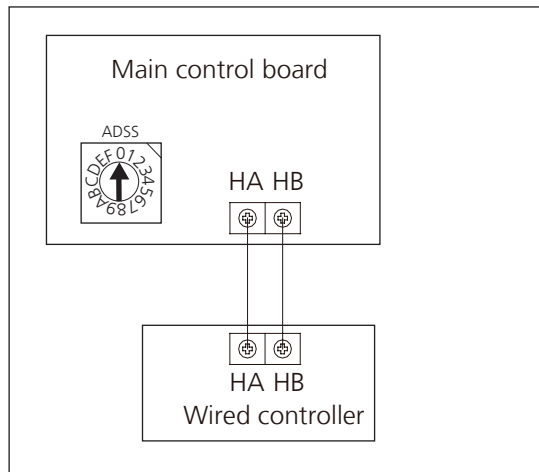

For Duct, Ceiling & floor: The wired controller connects to terminal board, terminal board connects to main control board.

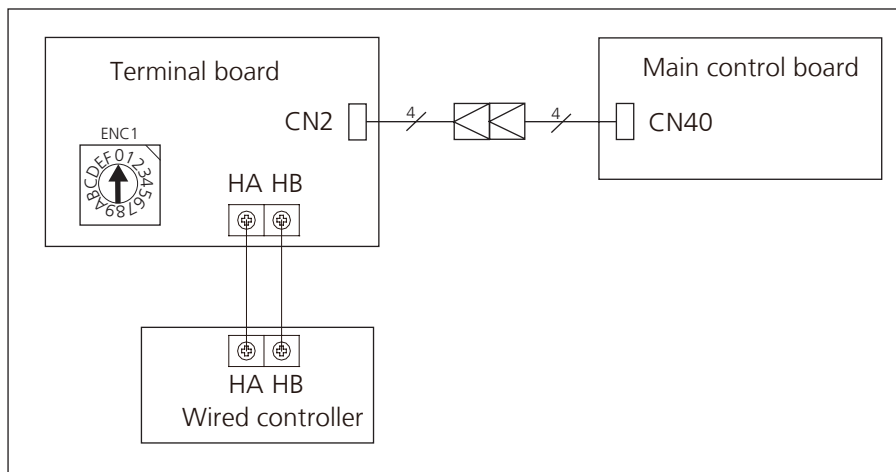

2) Address setting

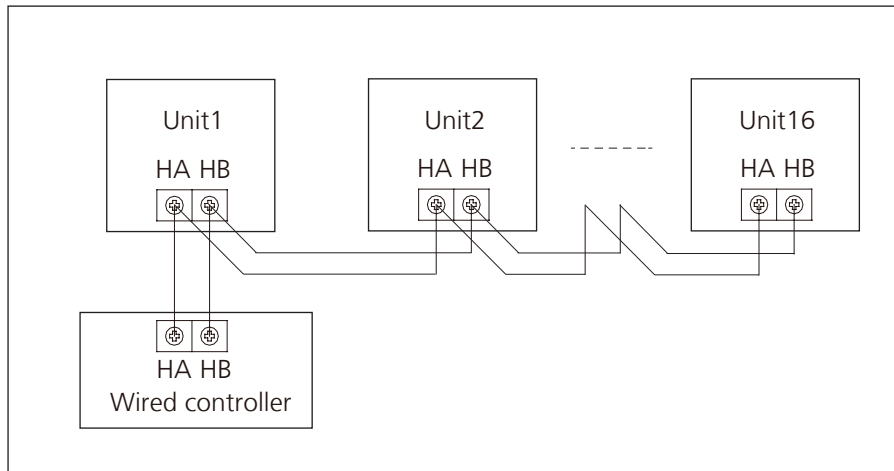

- One non-polarity controller can control up to 16 indoor units.
- When the non-polarity controller is connected to several units, every air-conditioner in network has only one network address to distinguish each other.
- Address code of air-conditioner in LAN is set by code switch ENC1(Duct and Ceiling& Floor) or ADSS(Cassette) of the indoor unit, and the set range is 0-15.
- Note: The indoor units are controlled at the same time, not independently. The purpose of setting network address is identify the unit when error occurs.

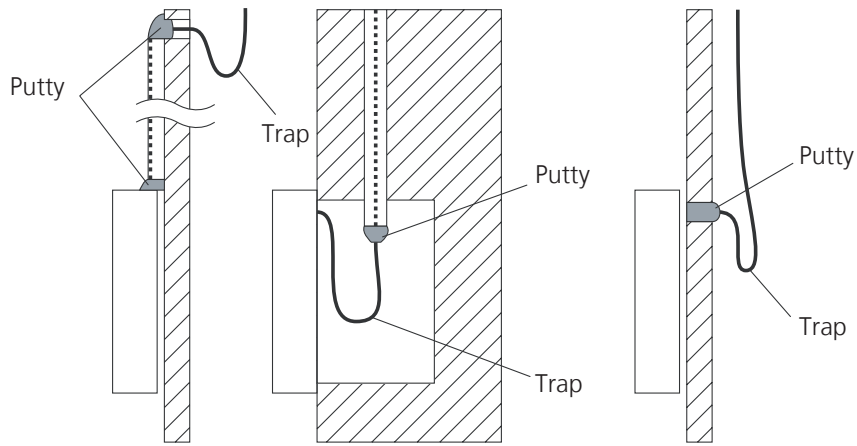

Note: DO NOT allow water to enter the remote control. Use the trap and putty to seal the wires.

• **For wiring the indoor unit, there are three methods:**

- From the rear;
- From the bottom;
- From the top;
- From the top center.

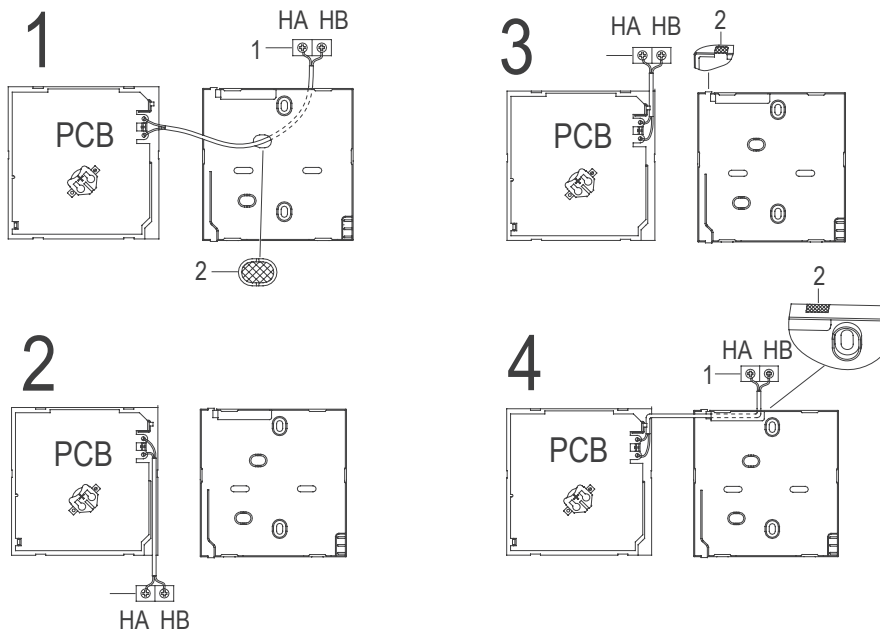

- 1: Indoor Unit.
- 2: Notch the part for the wiring to pass through with a nipper tool.
- Connect the terminals on the remote controller (HA ,HB), and the terminals of the indoor unit. (HA ,HB). (HA and HB do not have polarity.)

2.2 Centralized Controller

1) Connection

For Light commercial air conditioner with XYE port, it can be directly connected to Centralized Controller (CCM03, CCM09).

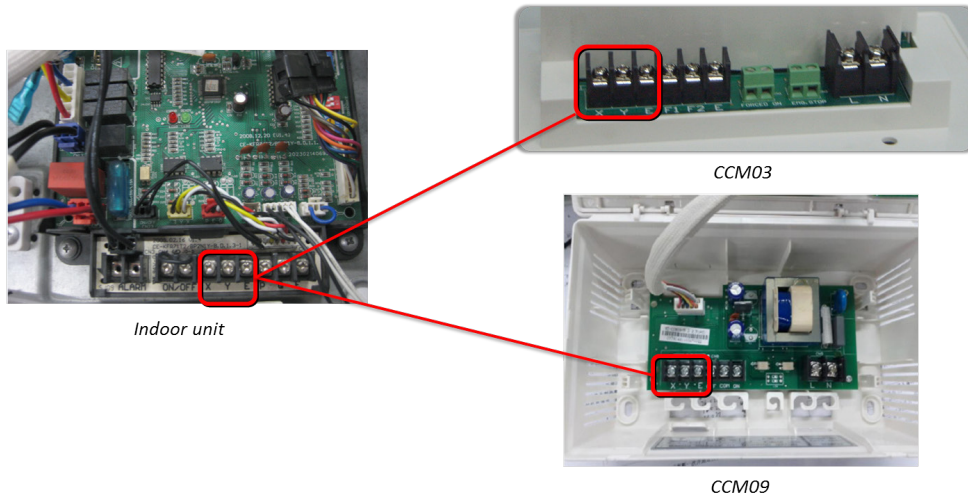

2) Address setting

When setting the address, please make sure the unit is powered off. The address can be set from 0 to 63 by the switch. Turn on the unit, then the address will be effective.

SWITCH		FOR CCM UNIT ADDRESS	
S2 + S1			
ADDRESS	0~15		16~31
Factory Setting	✓		
S2 + S1			
ADDRESS	32~47		48~63
Factory Setting			

Note: For light commercial air conditioner with XYE port, it can be also connected to BMS (Building Management System).

If there is any CAC (central air conditioner) connecting with the central controller at the same time, please set the address from largest (63,62,61...), since the CAC units could obtain address automatically from the smallest (00,01,02...)

2.3 Using the wire controller to set external static pressure

- You can use the unit's automatic airflow adjustment function to set external static pressure.
- Automatic airflow adjustment is the volume of blow-off air that has been automatically adjusted to the quantity rated.

1. Make sure the test run is done with a dry coil. If the coil is not dry, run the unit for 2 hours in FAN ONLY mode to dry the coil.

2. Check that both power supply wiring and duct installation have been completed. Check that any closing dampers are open. Check that the air filter is properly attached to the air suction side passage of the unit.

3. If there is more than one air inlet and outlet, adjust the dampers so that the airflow rate of each air inlet and outlet conforms with the designed airflow rate. Make sure the unit is in FAN ONLY mode. Press and set the airflow adjustment button on the remote control to change the airflow rate from H or L.

4. Set the parameters for automatic airflow adjustment. When the air conditioning unit is off, perform the following steps:

- When the unit is turned off, hold the MODE button and

FAN button down together for three seconds. ("AF" indicator flashes for 3 times.)

- Press "△" or "▽" to select the AF.

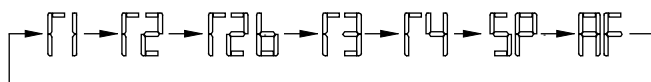

- Press "MODE". The air conditioning unit will then start the fan for airflow automatic adjustment.

After 3 to 6 minutes, the air conditioning unit stops operating once automatic airflow adjustment has finished.

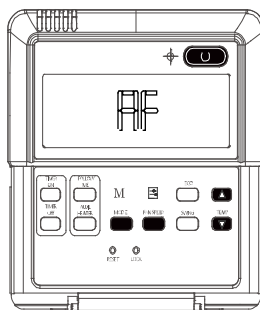

Caution: DO NOT adjust the dampers when automatic airflow adjustment is active.

Caution:

- If there is no change after airflow adjustment in the ventilation paths, be sure to reset automatic airflow adjustment.
- If there is no change to ventilation paths after airflow adjustment, contact your dealer, especially if this occurs after testing the outdoor unit or if the unit has been moved to a different location.
- Do not use automatic airflow adjustment with remote control, if you are using booster fans, outdoor air processing unit, or a HRV via duct.
- If the ventilation paths have been changed, reset airflow automatic adjustment as described from step 3 onwards.

2.4 Using the wire controller to set airflow rate

When the air conditioning unit is off, perform the following steps:

1. Press "MODE" and "FAN" for three seconds.

2. Press "△" or "▽" to select the SP.

3. Press "MODE" to set the airflow rate in the range of 0~4.

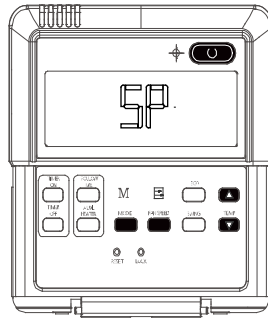

"0": No airflow change

"1" ~ "4": Airflow increase progressively







4. Press "ON/OFF" to finish the airflow setting.

Installation

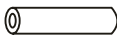
Contents

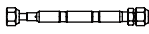
Accessories	73
1. Installation Overview	74
2. Location Selection	75
3. Indoor Unit Installation	76
4. Outdoor Unit Installation.....	78
5. Drainage Pipe Installation.....	79
6. Refrigerant Pipe Installation.....	82
7. Vacuum Drying and Leakage Checking.....	83
8. Additional Refrigerant Charge	84
9. Engineering of Insulation	85
10. Engineering of Electrical Wiring.....	86
11. Test Operation	86

Accessories

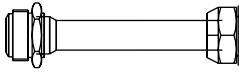
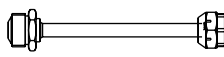
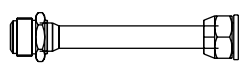
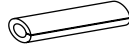
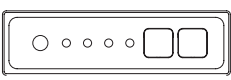
	Name	Shape	Quantity
Tubing & Fittings	Soundproof / insulation sheath		2
	Seal sponge (some models)		1
	Orifice (some models)		1
Drainpipe Fittings (for cooling & heating)	Drain joint (some models)		1
	Seal ring (some models)		1
EMC Magnetic Ring (some models)	Magnetic ring(Wrap the electric wires S1 & S2 (P & Q & E) around the magnetic ring twice)	 S1&S2(P&Q&E)	1
	Magnetic ring(Hitch on the connective cable between the indoor unit and outdoor unit after installation.)		1
Others	Owner's manual	-	1
	Installation manual	-	1
	Transfer connector($\phi 12.7$ - $\phi 15.9$)/($\phi 0.5$ in- $\phi 0.63$ in)(Packed with the indoor unit) NOTE: Pipe size may differ from appliance to appliance. To meet different pipe size requirements, sometimes the pipe connections need a transfer connector installed on the outdoor unit.		1 (on some models)
	Transfer connector($\phi 6.35$ - $\phi 9.52$)/($\phi 0.25$ in- $\phi 0.375$ in)(Packed with the indoor unit) NOTE: Pipe size may differ from appliance to appliance. To meet different pipe size requirements, sometimes the pipe connections need a transfer connector installed on the outdoor unit.		1 (on some models)
	Transfer connector($\phi 9.52$ - $\phi 12.7$)/($\phi 0.375$ in- $\phi 0.5$ in)(Packed with the indoor unit) NOTE: Pipe size may differ from appliance to appliance. To meet different pipe size requirements, sometimes the pipe connections need a transfer connector installed on the outdoor unit.		1 (on some models)
	Connecting wire for display (2m)	-	1(on some models)
	Cord protection rubber ring		1(on some models)
	Display panel *Just for testing purposes only		1(on some models- KJR-120G,KJR-120H)

Optional accessories:

- There are two types of remote controls: wired and wireless.
- Select a remote controller based on customer preferences and requirements and install in an appropriate place.
- Refer to catalogues and technical literature for guidance on selecting a suitable remote controller.

1. Installation Overview

Installation Order

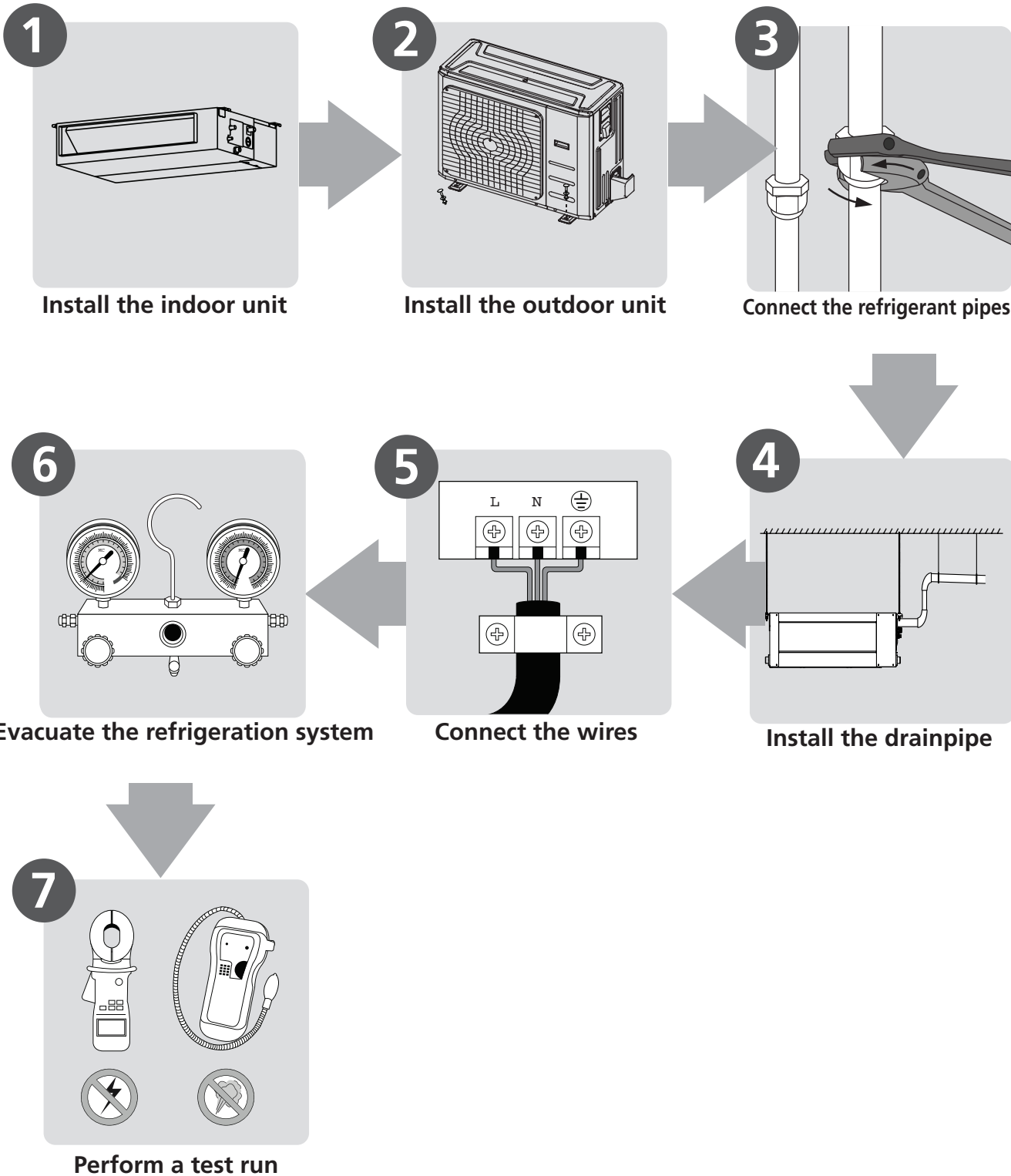

Installation

2. Location selection

2.1 Unit location selection can refer to installation manual.

2.2 **DO NOT** install the unit in the following locations:

- Where oil drilling or fracking is taking place.
- Coastal areas with high salt content in the air.
- Areas with caustic gases in the air, such as near hot springs.
- Areas with power fluctuations, such as factories.
- Enclosed spaces, such as cabinets.
- Areas with strong electromagnetic waves.
- Areas that store flammable materials or gas.
- Rooms with high humidity, such as bathrooms or laundry rooms.
- If possible, **DO NOT** install the unit where it is exposed to direct sunlight.

2.3 **The minimum distance between the outdoor unit and walls described in the installation guide does not apply to airtight rooms. Be sure to keep the unit unobstructed in at least two of the three directions (M, N, P)**

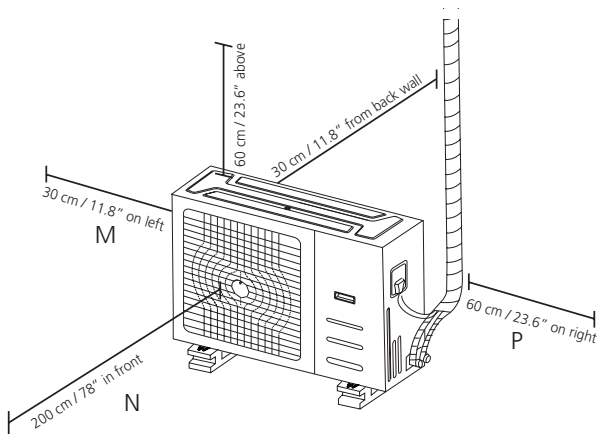

2.4 Rows of series installation

The relations between H, A and L are as follows.

	L	A
L ≤ H	$L \leq 1/2H$	25 cm / 9.8" or more
	$1/2H < L \leq H$	30 cm / 11.8" or more
L > H	Can not be installed	

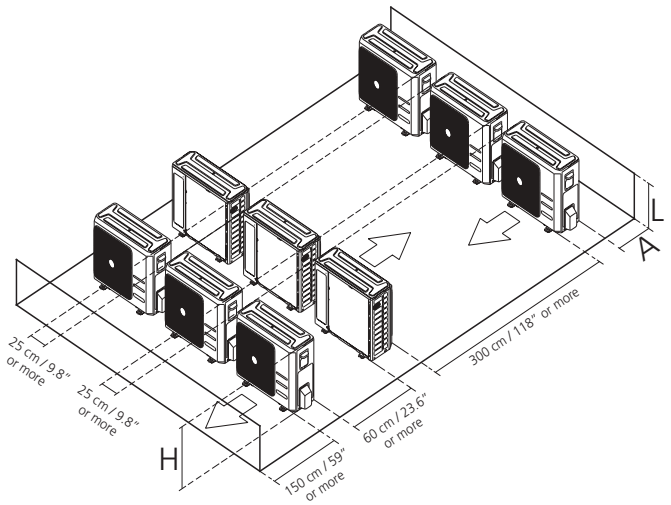

DO NOT install the rows of series like following figure.

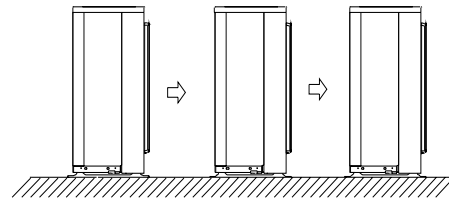

2.5 If the location is exposed to strong winds (for example: near a seaside), the unit must be placed against the wall to shelter it from the wind. If necessary, use an awning.

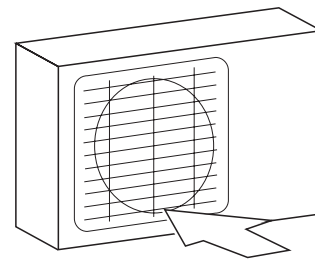

DO NOT Strong wind

3. Indoor Unit Installation

3.1 Service space for indoor unit

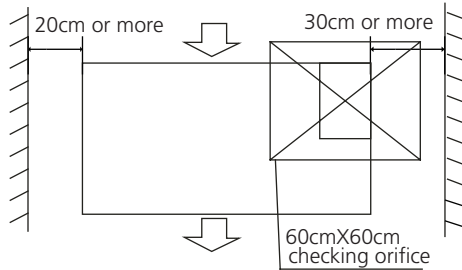

3.2 Hang Indoor Unit

1. Please refer to the following diagrams to locate the four positioning screw bolt hole on the ceiling. Be sure to mark the areas where ceiling hook holes will be drilled.

For A6 Duct,

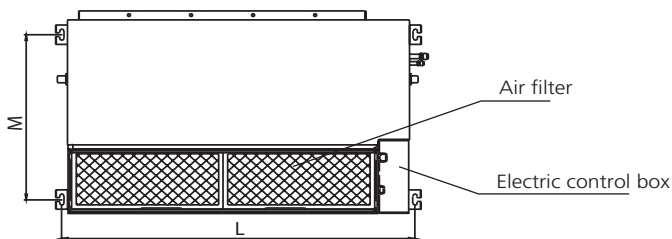

Capacity(KBtu/h)	Size of mounted plug	
	L	M
9/12	741	360
18	920	508
24	1140	598
30~36	1400	598
48	1240	697

For High-pressure Static Duct,

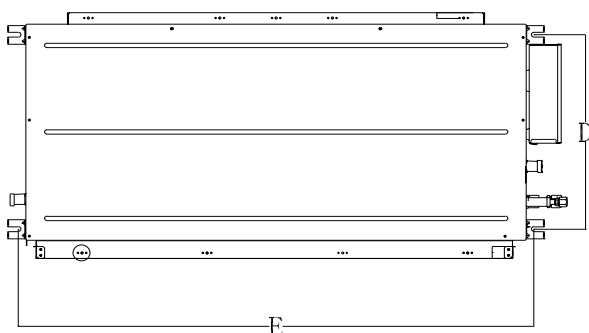

Capacity(KBtu/h)	Size of mounted plug	
	D	E
60	700	1436

2. Install and fit pipes and wires after you have finished

installing the main body. When choosing where to start, determine the direction of the pipes to be drawn out.

Especially in cases where there is a ceiling involved, align the refrigerant pipes, drain pipes, and indoor and outdoor lines with their connection points before mounting the unit..

3. Install hanging screw bolts.

- 1) Cut off the roof beam.
- 2) Strengthen the point at which the cut was made. Consolidate the roof beam..

4. After you select an installation location, align the refrigerant pipes, drain pipes, as well as indoor and outdoor wires with their connection points before mounting the unit..

5. Drill 4 holes 10cm (4") deep at the ceiling hook positions in the internal ceiling. Be sure to hold the drill at a 90° angle to the ceiling.

6. Secure the bolt using the included washers and nuts.

7. Install the four suspension bolts.

8. Mount the indoor unit with at least two people to lift and secure it. Insert suspension bolts into the unit's hanging holes. Fasten them using the washers and nuts provided.

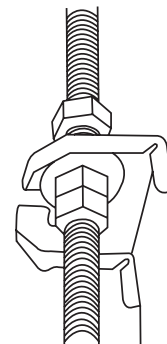

9. Mount the indoor unit onto the hanging screw bolts with a block. Position the indoor unit flat using a level indicator to prevent leaks.

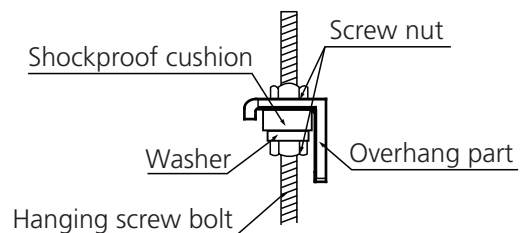

Note: Confirm the minimum drain tilt is 1/100 or more.

3.3 Duct and accessories installation

1. Install the filter(optional) according to air inlet size.
2. Install the canvas tie-in between the body and duct.
3. The air inlet and air outlet duct should be far enough apart enough to a avoid air passage short-circuit.
4. Connect the duct according to the following diagram.

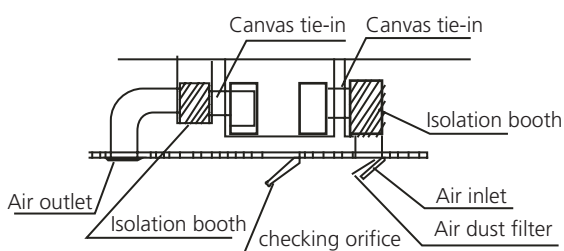

5. Refer to the following static pressure guidelines when installing the indoor unit.

Model(KBtu/h)	Static Pressure(Pa)
9/12	0-40
18	0-100
24-48	0-160
60	0-200

Change the fan motor static pressure according to external duct static pressure.

NOTE: 1. Do not put the connecting duct weight on the indoor unit.

2. When connecting duct, use inflammable canvas tie-in to prevent vibrating.

3. Insulation foam must be wrapped outside the duct to avoid condensate. An internal duct underlayer can be added to reduce noise, if the end-user requires.

3.4 Adjust the air inlet direction(From rear side to under-side.)

1. Take off ventilation panel and flange,

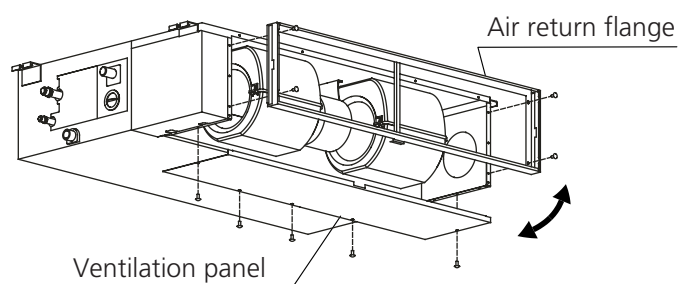

2. Change the mounting positions of ventilation panel and

air return flange .

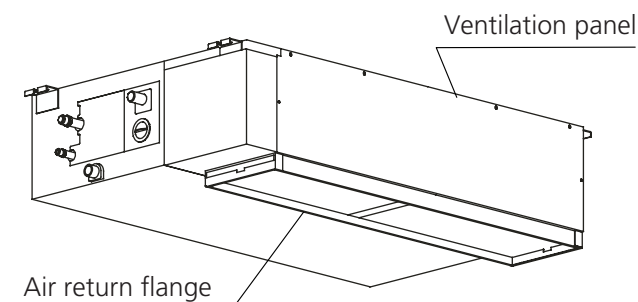

3. When installing the filter mesh, fit it into the flange as illustrated in the following figure.

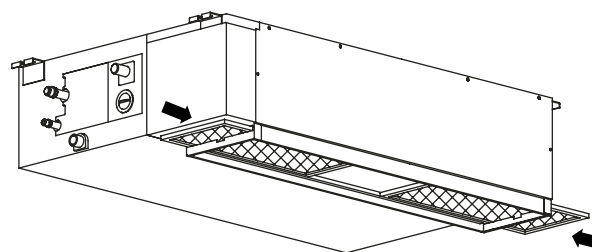

NOTE: All the figures in this manual are for demonstration purposes only. The air conditioner you have purchased may be slightly different in design, though similar in shape.

3.5 Fresh air duct installation

Dimension :

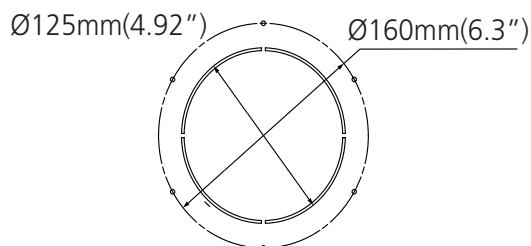
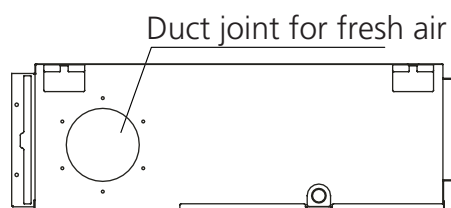

4. Outdoor unit installation(Side Discharge Unit)

4.1 Service space for outdoor unit

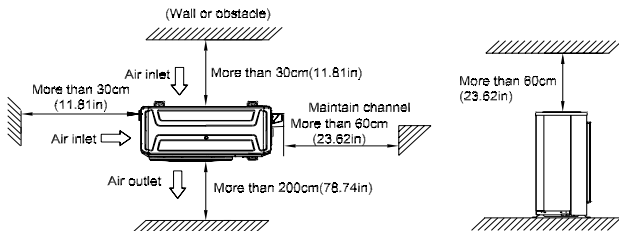

4.2 Bolt pitch

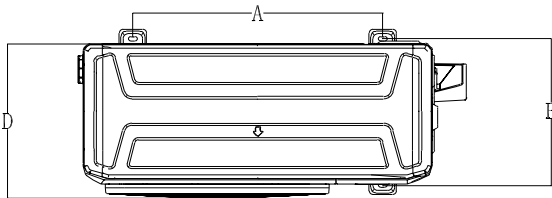

Capacity(KBtu/h)	unit	A	B	D
9	mm	487	298	300
	inch	19.2	11.7	11.8
12	mm	514	340	333
	inch	20.23	13.39	13.11
18	mm	540	350	363
	inch	21.26	13.78	14.29
24/36	mm	673	403	410
	inch	26.50	15.87	16.14
48/60	mm	415	634	404
	inch	16.4	25	15.9

4.3 Install Outdoor Unit

Fix the outdoor unit with anchor bolts(M10)

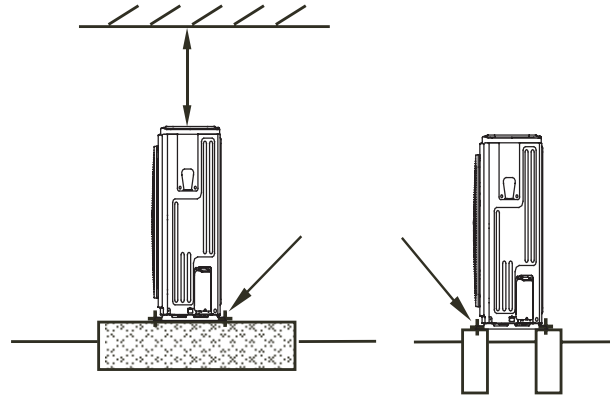

Cation

Since the gravity center of the unit is not at its physical center, so please be careful when lifting it with a sling.

Never hold the inlet of the outdoor unit to prevent it from deforming.

Do not touch the fan with hands or other objects.

Do not lean it more than 45°, and do not lay it sidelong.

Make concrete foundation according to the specifications of the outdoor units.

Fasten the feet of this unit with bolts firmly to prevent it from collapsing in case of earthquake or strong wind.

5. Drainage Pipe Installation

Install the drainage pipe as shown below and take measures against condensation. Improperly installation could lead to leakage and eventually wet furniture and belongings.

5.1 Installation principle

- Ensure at least 1/100 slope of the drainage pipe
- Adopt suitable pipe diameter
- Adopt nearby condensate water discharge

5.2 Key points of drainage water pipe installation

1. Considering the pipeline route and elevation.
 - Before installing condensate water pipeline, determine its route and elevation to avoid intersection with other pipelines and ensure slope is straight.
2. Drainage pipe selection
 - The drainage pipe diameter shall not small than the drain hose of indoor unit
 - According to the water flowrate and drainage pipe slope to choose the suitable pipe, the water flowrate is decided by the capacity of indoor unit.

Relationship between water flowrate and capacity of indoor unit

Capacity (kBtu/h)	Water flowrate (l/h)
12	2.4
18	4
24	6
30	7
36	8
42	10
48	12
55	14

According to the above table to calculate the total water flowrate for the confluence pipe selection.

For horizontal drainage pipe (The following table is for reference)

PVC pipe	Reference value of inner diameter of pipe (mm)	Allowable maximum water flowrate (l/h)		Remark
		Slope 1/50	Slope 1/100	
PVC25	20	39	27	For branch pipe
PVC32	25	70	50	
PVC40	31	125	88	Could be used for confluence pipe
PVC50	40	247	175	
PVC63	51	473	334	

Attention: Adopt PVC40 or bigger pipe to be the main pipe.

For Vertical drainage pipe (The following table is for reference)

PVC pipe	Reference value of inner diameter of pipe (mm)	Allowable maximum water flowrate (l/h)	Remark
PVC25	20	220	For branch pipe
PVC32	25	410	
PVC40	31	730	Could be used for confluence pipe
PVC50	40	1440	
PVC63	51	2760	
PVC75	67	5710	
PVC90	77	8280	

Attention: Adopt PVC40 or bigger pipe to be the main pipe.

3. Individual design of drainage pipe system
 - The drainage pipe of air conditioner shall be installed separately with other sewage pipe, rainwater pipe and drainage pipe in building.
 - The drainage pipe of the indoor unit with water pump should be apart from the one without water pump.
4. Supporter gap of drainage pipe
 - In general, the supporter gap of the drainage pipe horizontal pipe and vertical pipe is respectively 1m~1.5m and 1.5m~2.0m.
 - Each vertical pipe shall be equipped with not less than two hangers.
 - Overlarge hanger gap for horizontal pipe shall create bending, thus leading to air block.

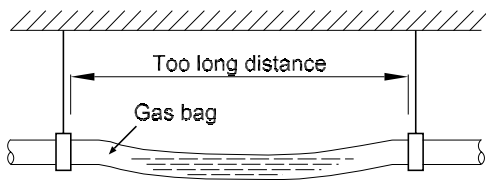

5. The horizontal pipe layout should avoid converse flow or bad flow

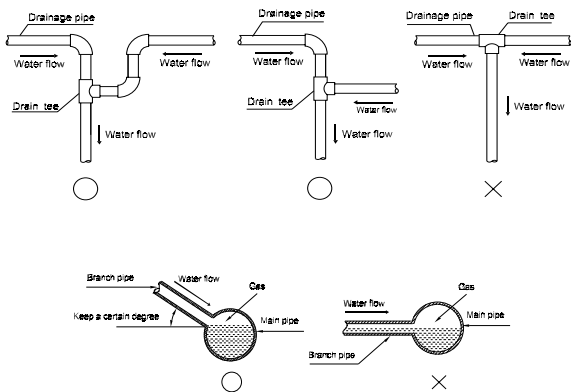

- The correct installation will not cause converse water flow and the slope of the branch pipes can be adjusted freely
- The false installation will cause converse water flow and the slope of the branch pipe can not be adjusted.

6. Water storage pipe setting

- If the indoor unit has high extra static pressure and without water pump to elevate the condensate water, such as high extra static pressure duct unit, the water storage pipe should be set to avoid converse flow or blow water phenomena.

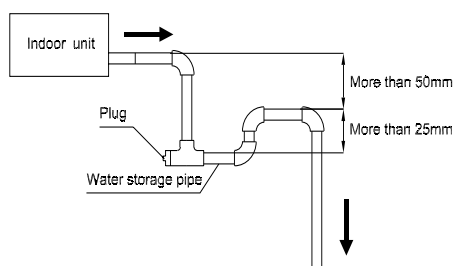

7. Lifting pipe setting of indoor unit with water pump

- The length of lifting pipe should not exceed 750mm.
- The drainage pipe should be set down inclined after the lifting pipe immediately to avoid wrong operation of water level switch.

- Refer the following picture for installation reference.

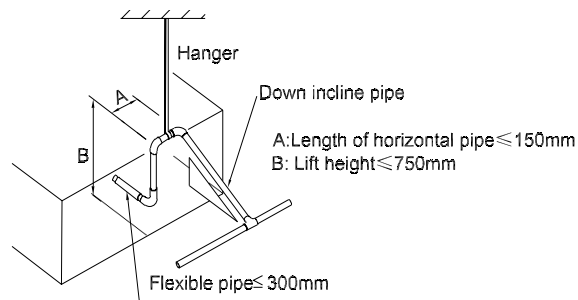

8. Blowhole setting

- For the concentrated drainage pipe system, there should design a blowhole at the highest point of main pipe to ensure the condensate water discharge smoothly.
- The air outlet shall face down to prevent dirt entering pipe.
- Each indoor unit of the system should be installed it.
- The installation should be considering the convenience for future cleaning.

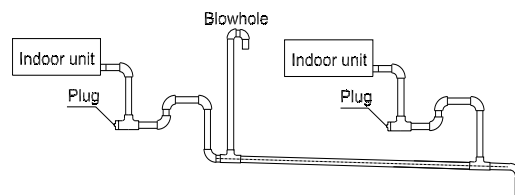

9. The end of drainage pipe shall not contact with ground directly.

5.3 Drainage test

1. Water leakage test

- After finishing the construction of drainage pipe system, fill the pipe with water and keep it for 24 hours to check whether there is leakage at joint section.

2. Water discharge test

Check that the drainpipe is unhindered.

This test should be performed on newly built houses before the ceiling is paved.

2.1 Units without a pump

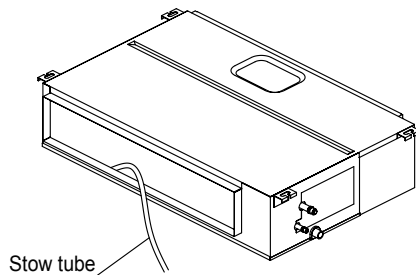

- Fill the water pan with 2 liters of water.
- Check that the drainpipe is unhindered

.2.2 Units with a pump

1. Remove the test cover.
- Fill the water pan with 2 liters of water.

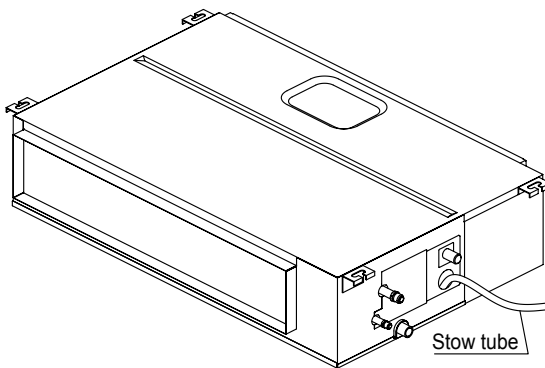
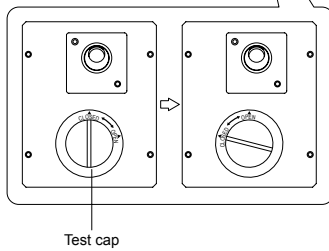
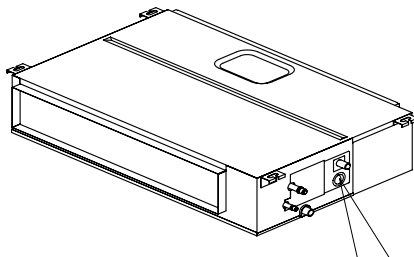

2. Turn on the unit in COOLING mode. You will hear the drain pump. Check whether the water is discharged properly (a 1-minute lag is possible, depending on the length of the drain pipe), Check whether water leaks from the joints.

3. Turn off the air conditioner and put the cap back on.
 - After turn off the air conditioner 3 minutes, check whether there is anything abnormal. If drainage pipes have not been distributed properly, over back-flow water shall cause the flashing of alarm indicator at remote-controlled receiving board and

even water shall run over the water collector.

- Continuously infusing water until water level alarmed, check whether the drainage pump could discharge water at once. If water level does not decline under warning water level 3 minutes later, it shall cause shutdown of unit. When this situation happens, the normal startup only can be recovered by turning down power supply and eliminating accumulated water.

Note: Drain plug at the main water-containing plate is used for eliminating accumulated water in water-containing plate when maintaining air conditioner fault. During normal operation, the plug shall be filled in to prevent leakage.

5.4 Insulation work of drainage pipe

Refer the introduction to the insulation engineering parts.

6. Refrigerant Pipe Installation

6.1 Maximum length and drop height

Ensure that the length of the refrigerant pipe, the number of bends, and the drop height between the indoor and outdoor units meets the requirements shown in the following table.

Capacity(kBtu/h)	Max. Length (m/ft)	Max. Elevation (m/ft)
9/12	25/82	10/32.8
18	30/98.4	20/65.6
24~30	50/164	25/82
36~60	65/213.3	30/98.4

caution:

- The capacity test is based on the standard length and the maximum permissible length is based on the system reliability.
- Oil traps

If the indoor unit is installed higher than the outdoor unit:

-If oil flows back into the outdoor unit's compressor, this might cause liquid compression or deterioration of oil return. Oil traps in the rising gas piping can prevent this.

An oil trap should be installed every 10m(32.8ft) of vertical suction line riser.

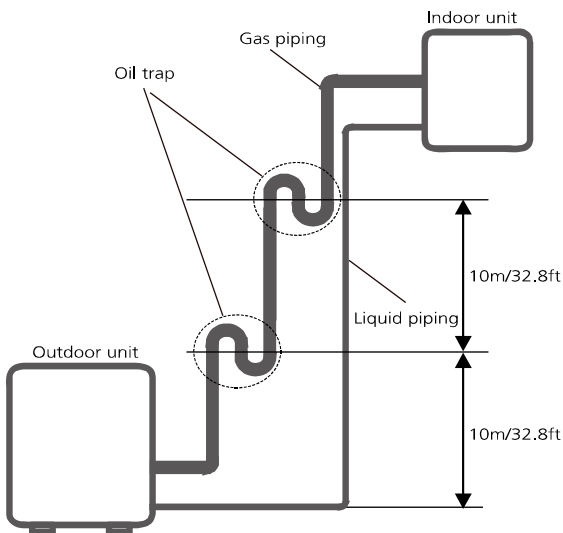

The indoor unit is installed higher than the outdoor unit

If the outdoor unit is installed higher than the indoor unit:

-It is recommended that vertical suction risers not be upsized. Proper oil return to the compressor should be maintained with suction gas velocity. If velocities drop below 7.62m/s(1500fpm (feet per minute)), oil return will be decreased. An oil trap should be installed every

6m(20ft) of vertical suction line riser.

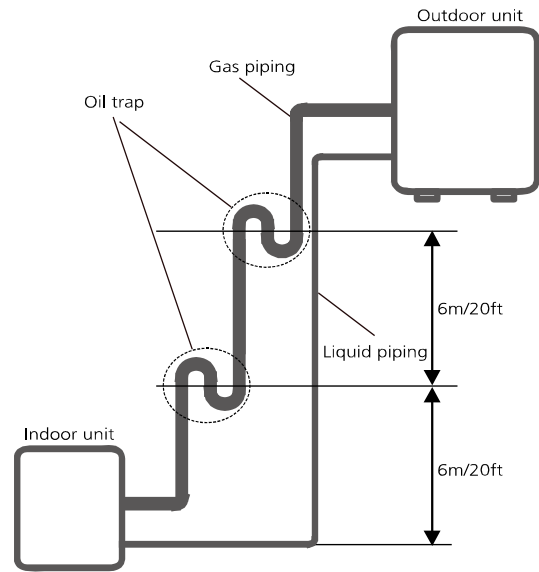

The outdoor unit is installed higher than the indoor unit.

6.2 The procedure of connecting pipes

1. Choose the pipe size according to the specification table.
2. Confirm the cross way of the pipes.
3. Measure the necessary pipe length.
4. Cut the selected pipe with pipe cutter
 - Make the section flat and smooth.

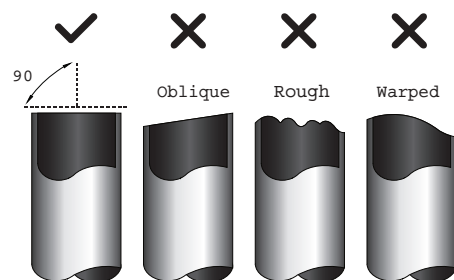

5. Insulate the copper pipe
 - Before test operation, the joint parts should not be heat insulated.
6. Flare the pipe
 - Insert a flare nut into the pipe before flaring the pipe
 - According to the following table to flare the pipe.

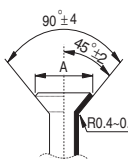
Pipe diameter (inch(mm))	Flare dimension A (mm/inch)		Flare shape
	Min	Max	
1/4" (6.35)	8.4/0.33	8.7/0.34	
3/8" (9.52)	13.2/0.52	13.5/0.53	
1/2" (12.7)	16.2/0.64	16.5/0.65	
5/8" (15.9)	19.2/0.76	19.7/0.78	
3/4" (19)	23.2/0.91	23.7/0.93	
7/8" (22)	26.4/1.04	26.9/1.06	

- After flared the pipe, the opening part must be seal by end cover or adhesive tape to avoid duct or exogenous impurity come into the pipe.

7. Drill holes if the pipes need to pass the wall.

8. According to the field condition to bend the pipes so that it can pass the wall smoothly.

9. Bind and wrap the wire together with the insulated pipe if necessary.

10. Set the wall conduit

11. Set the supporter for the pipe.

12. Locate the pipe and fix it by supporter

- For horizontal refrigerant pipe, the distance between supporters should not be exceed 1m.
- For vertical refrigerant pipe, the distance between supporters should not be exceed 1.5m.

13. Connect the pipe to indoor unit and outdoor unit by using two spanners.

- Be sure to use two spanners and proper torque to fasten the nut, too large torque will damage the bellmouthing, and too small torque may cause leakage. Refer the following table for different pipe connection.

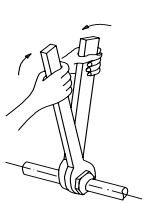
Pipe Diameter	Torque	Sketch map
	N.m(lb.ft)	
1/4" (6.35)	15~16 (11~11.8)	
3/8" (9.52)	25~26 (18.4~19.18)	
1/2" (12.7)	35~36 (25.8~26.55)	
5/8" (15.9)	45~47 (33.19~34.67)	
3/4" (19)	65~67 (47.94~49.42)	
7/8" (22)	75~85 (55.3~62.7)	

7. Vacuum Drying and Leakage Checking

7.1 Purpose of vacuum drying

- Eliminating moisture in system to prevent the phenomena of ice-blockage and copper oxidation. Ice-blockage shall cause abnormal operation of system, while copper oxide shall damage compressor.
- Eliminating the non-condensable gas (air) in system to prevent the components oxidizing, pressure fluctuation and bad heat exchange during the operation of system.

7.2 Selection of vacuum pump

- The ultimate vacuum degree of vacuum pump shall be -756mmHg or above.
- Precision of vacuum pump shall reach 0.02mmHg or above.

7.3 Operation procedure for vacuum drying

Due to different construction environment, two kinds of vacuum drying ways could be chosen, namely ordinary vacuum drying and special vacuum drying.

7.3.1 Ordinary vacuum drying

- When conduct first vacuum drying, connect pressure gauge to the infusing mouth of gas pipe and liquid pipe, and keep vacuum pump running for 1 hour (vacuum degree of vacuum pump shall be reached -755mmHg).
- If the vacuum degree of vacuum pump could not reach -755mmHg after 1 hour of drying, it indicates that there is moisture or leakage in pipeline system and need to go on with drying for half an hour.
- If the vacuum degree of vacuum pump still could not reach -755mmHg after 1.5 hours of drying, check whether there is leakage source.
- Leakage test: After the vacuum degree reaches -755mmHg, stop vacuum drying and keep the pressure for 1 hour. If the indicator of vacuum gauge does not go up, it is qualified. If going up, it indicates that there is moisture or leak source.

7.3.2 Special vacuum drying

The special vacuum drying method shall be adopted when:

- Finding moisture during flushing refrigerant pipe.
- Conducting construction on rainy day, because rain

water might penetrated into pipeline.

3. Construction period is long, and rain water might penetrated into pipeline.

4. Rain water might penetrate into pipeline during construction.

Procedures of special vacuum drying are as follows:

1. Vacuum drying for 1 hour.

2. Vacuum damage, filling nitrogen to reach 0.5Kgf/cm² .

Because nitrogen is dry gas, vacuum damage could achieve the effect of vacuum drying, but this method could not achieve drying thoroughly when there is too much moisture. Therefore, special attention shall be drawn to prevent the entering of water and the formation of condensate water.

3. Vacuum drying again for half an hour.

If the pressure reached -755mmHg, start to pressure leakage test. If it cannot reached the value, repeat vacuum damage and vacuum drying again for 1 hour.

4. Leakage test: After the vacuum degree reaches -755mmHg, stop vacuum drying and keep the pressure for 1 hour. If the indicator of vacuum gauge does not go up, it is qualified. If going up, it indicates that there is moisture or leak source.

8. Additional Refrigerant Charge

- After the vacuum drying process is carried out, the additional refrigerant charge process need to be performed.
- The outdoor unit is factory charged with refrigerant. The additional refrigerant charge volume is decided by the diameter and length of the liquid pipe between indoor and outdoor unit. Refer the following formula to calculate the charge volume.

Diameter of liquid pipe (mm)	Formula
6.35	$V=15g/m \times (L-5)$
9.52	$V=30g/m \times (L-5)$

V: Additional refrigerant charge volume (g).

L : The length of the liquid pipe (m).

Note:

- Refrigerant may only be charged after performed the vacuum drying process.
- Always use gloves and glasses to protect your hands and eyes during the charge work.
- Use electronic scale or fluid infusion apparatus to weight refrigerant to be recharged. Be sure to avoid extra refrigerant charged, it may cause liquid hammer of the compressor or protections.
- Use supplementing flexible pipe to connect refrigerant cylinder, pressure gauge and outdoor unit. And The refrigerant should be charged in liquid state. Before recharging, The air in the flexible pipe and manifold gauge should be exhausted.
- After finished refrigerant recharge process, check whether there is refrigerant leakage at the connection joint part.(Using gas leakage detector or soap water to detect).

9. Engineering of Insulation

9.1 Insulation of refrigerant pipe

1. Operational procedure of refrigerant pipe insulation

Cut the suitable pipe → insulation (except joint section) → flare the pipe → piping layout and connection → vacuum drying → insulate the joint parts

2. Purpose of refrigerant pipe insulation

- During operation, temperature of gas pipe and liquid pipe shall be over-heating or over-cooling extremely. Therefore, it is necessary to carry out insulation; otherwise it shall debase the performance of unit and burn compressor.
- Gas pipe temperature is very low during cooling. If insulation is not enough, it shall form dew and cause leakage.
- Temperature of gas pipe is very high (generally 50-100 °C) during heating. Insulation work must be carried out to prevent hurt by carelessness touching.

3. Insulation material selection for refrigerant pipe

- The burning performance should over 120 °C
- According to the local law to choose insulation materials
- The thickness of insulation layer shall be above 10mm. If in hot or wet environment place, the layer of insulation should be thicker accordingly.

4. Installation highlights of insulation construction

- Gas pipe and liquid pipe shall be insulated separately, if the gas pipe and liquid pipe were insulated together; it will decrease the performance of air conditioner.

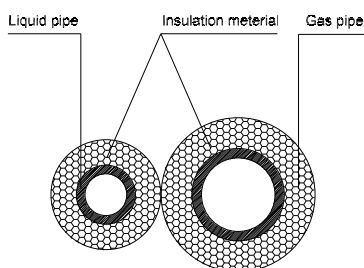

- The insulation material at the joint pipe shall be 5~10cm longer than the gap of the insulation material.
- The insulation material at the joint pipe shall be inserted into the gap of the insulation material.
- The insulation material at the joint pipe shall be banded to the gap pipe and liquid pipe tightly.
- The linking part should be use glue to paste together
- Be sure not bind the insulation material over-tight, it may extrude out the air in the material to cause bad

insulation and cause easy aging of the material.

9.2 Insulation of drainage pipe

1. Operational procedure of refrigerant pipe insulation

Select the suitable pipe → insulation (except joint section) → piping layout and connection → drainage test → insulate the joint parts

2. Purpose of drainage pipe insulation

The temperature of condensate drainage water is very low. If insulation is not enough, it shall form dew and cause leakage to damage the house decoration.

3. Insulation material selection for drainage pipe

- The insulation material should be flame retardant material, the flame retardancy of the material should be selected according to the local law.
- Thickness of insulation layer is usually above 10mm.
- Use specific glue to paste the seam of insulation material, and then bind with adhesive tape. The width of tape shall not be less than 5cm. Make sure it is firm and avoid dew.

4. Installation and highlights of insulation construction

- The single pipe should be insulated before connecting to another pipe, the joint part should be insulated after the drainage test.
- There should be no insulation gap between the insulation material.

10. Engineering of Electrical Wiring

10.1 Highlights of electrical wiring installation

- All field wiring construction should be finished by qualified electrician.
- Air conditioning equipment should be grounded according to the local electrical regulations.
- Current leakage protection switch should be installed.
- Do not connect the power wire to the terminal of signal wire.
- When power wire is parallel with signal wire, put wires to their own wire tube and remain at least 300mm gap.
- According to table in indoor part named "the specification of the power" to choose the wiring, make sure the selected wiring not small than the date showing in the table.
- Select different colors for different wire according to relevant regulations.
- Do not use metal wire tube at the place with acid or alkali corrosion, adopt plastic wire tube to replace it.
- There must be not wire connect joint in the wire tube If joint is a must, set a connection box at the place.
- The wiring with different voltage should not be in one wire tube.
- Ensure that the color of the wires of outdoor and the terminal No. are same as those of indoor unit respectively.
- You must first choose the right cable size before preparing it for connection. Be sure to use H07RN-F cables.

Table: Minimum Cross-Sectional Area able of Power and Signal Cables

Rated Current of Appliance (A)	Nominal Cross-Sectional Area(mm ²)
≤ 6	0.75
6 - 10	1
10 - 16	1.5
16 - 25	2.5
25 - 32	4
32 - 45	6

11. Test Operation

11.1 The test operation must be carried out after the entire installation has been completed.

11.2 Please confirm the following points before the test operation.

- The indoor unit and outdoor unit are installed properly.
- Tubing and wiring are correctly completed.
- The refrigerant pipe system is leakage-checked.
- The drainage is unimpeded.
- The ground wiring is connected correctly.
- The length of the tubing and the added stow capacity of the refrigerant have been recorded.
- The power voltage fits the rated voltage of the air conditioner.
- There is no obstacle at the outlet and inlet of the outdoor and indoor units.
- The gas-side and liquid-side stop valves are both opened.
- The air conditioner is pre-heated by turning on the power.

11.3 Test operation

1. Open both the liquid and gas stop valves.
2. Turn on the main power switch and allow the unit to warm up.
3. Set the air conditioner to COOL mode, and check the following points.

Indoor unit

- Whether the switch on the remote controller works well.
- Whether the buttons on the remote controller works well.
- Whether the air flow louver moves normally.
- Whether the room temperature is adjusted well.
- Whether the indicator lights normally.
- Whether the temporary buttons works well.
- Whether the drainage is normal.
- Whether there is vibration or abnormal noise during operation.

Outdoor unit

- Whether there is vibration or abnormal noise during operation.
- Whether the generated wind, noise, or condensed of by the air conditioner have influenced your neighborhood.
- Whether any of the refrigerant is leaked.

Static Pressure Design

Contents

1.	Introduction	88
2.	Charts for friction losses in round ducts	88
3.	Dynamic losses.....	89
4.	Corresponding relation between Rectangular duct and Round Duct	90
5.	Method for duct calculation	91
6.	Unit conversion.....	91
7.	Recommended outlet velocity for different occasions	91

1. Introduction

Duct system losses are the irreversible transformation of mechanical energy into heat. The two types of losses are (1) friction losses and (2) dynamic losses.

Friction losses are due to fluid viscosity and result from momentum exchange between molecules (in laminar flow) or between individual particles of adjacent fluid layers moving at different velocities (in turbulent flow). Friction losses occur along the entire duct length.

Dynamic losses result from flow disturbances caused by duct mounted equipment and fittings (e.g., entries, exits, elbows, transitions, and junctions) that change the airflow path's direction or area.

2. Charts For Friction Losses In Round Ducts

Fluid resistance caused by friction in round ducts can be determined by the friction chart. (based on galvanized sheet)

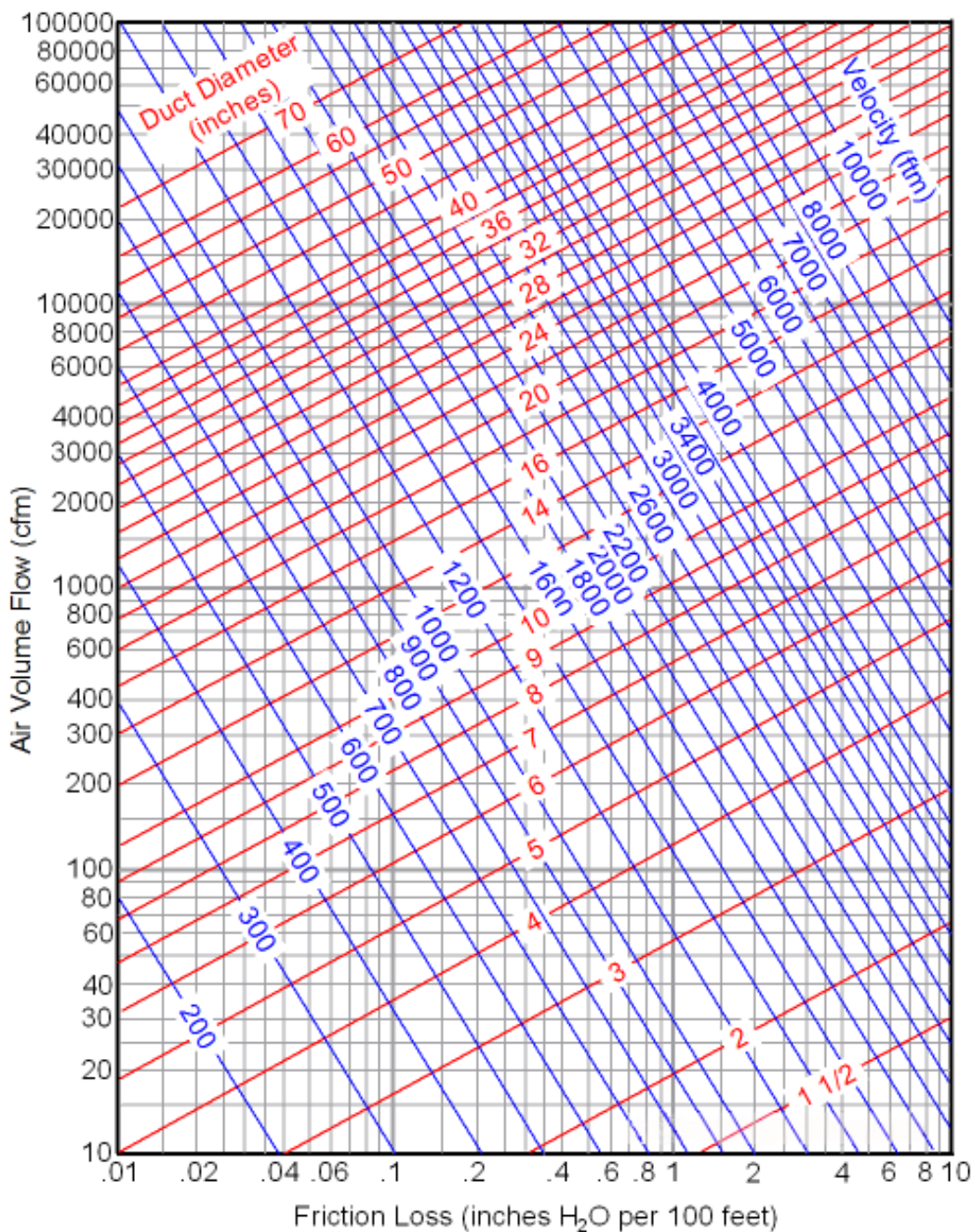

3. Dynamic Losses

For dynamic losses, please refer to below image.

$H' =$

Elbow ($r/w = 1$)		+	Sharp elbow ($r/w = 0.5$)		+	Branch Straight-Thru		+	Branch Thru-Branch ($r/w = 1$)		+	Reducer $\theta \leq 14^\circ$		
V m/s	loss mm H ₂ O		V m/s	loss mm H ₂ O		No friction loss			V m/s	loss mm H ₂ O		V m/s	loss mm H ₂ O	
3.5~5	0.2		3.5~5	1					3.5~5	0.4		3.5~5	0.2	
5~7	0.4		5~7	2				5~7	0.8	5~7	0.4		5~7	0.4
7~9	0.8 ^x	piece	7~9	3.5 ^x	piece			7~9	1.5 ^x	7~9	1.5 ^x	piece	7~9	0.8 ^x
9~15	2		9~15	7				9~15	3	9~15	2		9~15	2
Anemostat		+	Gallery or louver		+	Register		+	Hopper					
V m/s	loss mm H ₂ O		V m/s	loss mm H ₂ O		V m/s	loss mm H ₂ O		V m/s	loss mm H ₂ O				
3.5~5	1		3.5~5	0.5		3.5~5	1.5		3.5~5	0.3				
5~7	2		5~7	1		5~7	3		5~7	0.6				
7~9	3.5		7~9	2		7~8	6		7~9	1				
9~15	6													

Note: W Shows a diameter of round duct or long side length of the rectangular duct.

4. Corresponding Relation Between Rectangular Duct and Round Duct

Circular Duct Diameter, in.	Length of One Side of Rectangular Duct ^a , in.																			
	4	5	6	7	8	9	10	12	14	16	18	20	22	24	26	28	30	32	34	36
	Length Adjacent Side of Rectangular Duct ^b , in.																			
5	5																			
5.5	6	5																		
6	8	6																		
6.5	9	7	6																	
7	11	8	7																	
7.5	13	10	8	7																
8	15	11	9	8																
8.5	17	13	10	9																
9	20	15	12	10	8															
9.5	22	17	13	11	9															
10	25	19	15	12	10	9														
10.5	29	21	16	14	12	10														
11	32	23	18	15	13	11	10													
11.5		26	20	17	14	12	11													
12		29	22	18	15	13	12													
12.5		32	24	20	17	15	13													
13		35	27	22	18	16	14	12												
13.5		38	29	24	20	17	15	13												
14			32	26	22	19	17	14												
14.5			35	28	24	20	18	15												
15			38	30	25	22	19	16	14											
16			45	36	30	25	22	18	15											
17				41	34	29	25	20	17	16										
18				47	39	33	29	23	19	17										
19				54	44	38	33	26	22	19	18									
20					50	43	37	29	24	21	19									
21					57	48	41	33	27	23	20									
22					64	54	46	36	30	26	23	20								
23						60	51	40	33	28	25	22								
24						66	57	44	36	31	27	24	22							
25							63	49	40	34	29	26	24							
26							69	54	44	37	32	28	26	24						
27							76	59	48	40	35	31	28	25						
28								64	52	43	38	33	30	27	26					
29								70	56	47	41	36	32	29	27					
30								76	61	51	44	39	35	31	29	28				
31								82	66	55	47	41	37	34	31	29				
32								89	71	59	51	44	40	36	33	31				
33								96	76	64	54	48	42	38	35	33	30			
34									82	68	58	51	45	41	37	35	32			
35									88	73	62	54	48	44	40	37	34	32		
36									95	78	67	58	51	46	42	39	36	34		
37									101	83	71	62	55	49	45	41	38	36	34	
38									108	89	76	66	58	52	47	44	40	38	36	
39										95	80	70	62	55	50	46	43	40	37	36
40										101	85	74	65	58	53	49	45	42	39	37
41										107	91	78	69	62	56	51	47	44	41	39
42										114	96	83	73	65	59	54	50	46	44	41
43										120	102	88	77	69	62	57	53	49	46	43
44											107	93	81	73	66	60	55	51	48	45
45											113	98	86	76	69	63	58	54	50	47
46											120	103	90	80	72	66	61	56	53	49
47											126	108	95	84	76	69	64	59	55	52
48											133	114	100	89	80	73	67	62	58	54
49											140	120	105	93	84	76	70	65	60	56
50											147	126	110	98	88	80	73	68	63	59
51												132	115	102	92	83	76	71	66	61
52												139	121	107	96	87	80	74	69	64
53												145	127	112	100	91	83	77	71	67
54												152	133	117	105	95	87	80	74	70
55													139	123	110	99	91	84	78	72
56													145	128	114	104	95	87	81	75
57													151	134	119	108	98	91	84	78
58													158	139	124	112	102	94	87	81
59													165	145	130	117	107	98	91	85
60													172	151	135	122	111	102	94	88

5. Method For Duct Calculation (equal friction method)

- 1) Draw schematic view of the duct system.
- 1) Make notes for air volume and mark clearly the elbow, the branch parts, the air discharge outlet.
- 1) Select one main ducting route (where the maximum static pressure loss occurs).
- 1) Select the air velocity for the main duct in accordance with the desirable air velocity.

Main duct	Typical design velocity (m/s)		
	Residence	Public building	Factory
	3.5~6.0	5.0~8.0	6.0~11.0

- 1) Since the velocity and air volume are fixed for main duct, then use the Friction loss chart to find standard friction loss.
- 1) Use air volume and friction loss to find corresponding duct size and velocity for each part of main duct through Frictions loss chart.
- 1) Find the dynamic loss of main ducting route according to the velocity. and type of special fittings (elbows, junctions, regulating flaps, etc.)
- 1) Obtain the duct size and velocity of each branch duct based on the air volume and the same standard friction loss as for the main duct.
- 1) Find the dynamic loss of branch duct.
- 1) Calculate the total pressure loss.

6. Unit Conversion

- 1 inch water=248.8 N/m² (Pa)=0.0361 lb/in² (psi)=25.4 kg/cm²=0.0739 in mercury
- 1 ft³/min (cfm)=1.7 m³/h
- 1 ft/min=5.08*10⁻³ m/s
- 1 inch=2.54 cm=0.0254m=0.08333ft

7. Recommended Outlet Velocity For Different Occasion

The permissible sound level and correspondingly maximum air velocity, is determined by the occasion.

Noise / dB(A)	Occasion	Maximum velocity / m/s
25	Studio, recording room	2
35	Cinema, hospital, library	3
40	Office, school, hotel	4
46	Bank, public hall	5
50	Store, post office	6
70	Factory	10